



## TEGA INDUSTRIES LIMITED

Our Company was incorporated as "Tega India Limited" under the Companies Act, 1956, as a public limited company at Kolkata, West Bengal, pursuant to a certificate of incorporation dated May 15, 1976, issued by the Registrar of Companies, West Bengal at Kolkata ("Registrar of Companies"). Our Company received a certificate of commencement of business on May 28, 1976 from the Registrar of Companies. For details of changes in name and registered office of our Company since incorporation, see "History and Certain Corporate Matters" beginning on page 170.

**Registered Office:** 147, Block-G, New Alipore, Kolkata 700 053, West Bengal, India  
**Corporate Office:** Office Space No. 807, 8<sup>th</sup> Floor, Godrej Waterside-Tower II, DP-5, Bidhannagar, Salt Lake, Sector V, Kolkata 700 091, West Bengal, India  
**Contact Person:** Sudipta Bhowal, Company Secretary and Compliance Officer; Tel: +91 33 3001 9000  
**E-mail:** compliance.officer@tegaindustries.com; **Website:** www.tegaindustries.com  
**Corporate Identity Number:** U25199WB1976PLC030532

### OUR PROMOTERS: MADAN MOHAN MOHANKA, MANJU MOHANKA, MANISH MOHANKA, MEHUL MOHANKA AND NIHAL FISCAL SERVICES PRIVATE LIMITED

INITIAL PUBLIC OFFERING OF UP TO 13,669,478 EQUITY SHARES OF FACE VALUE OF ₹ 10 EACH (THE "EQUITY SHARES") OF TEGA INDUSTRIES LIMITED (OUR "COMPANY" OR THE "ISSUER") FOR CASH AT A PRICE OF ₹ [·] PER EQUITY SHARE (INCLUDING A SHARE PREMIUM OF ₹ [·] PER EQUITY SHARE) (THE "OFFER PRICE") AGGREGATING UP TO ₹ [·] MILLION (THE "OFFER") COMPRISING AN OFFER FOR SALE OF UP TO 3,314,657 EQUITY SHARES AGGREGATING UP TO ₹ [·] MILLION BY MADAN MOHAN MOHANKA, UP TO 662,931 EQUITY SHARES AGGREGATING UP TO ₹ [·] MILLION BY MANISH MOHANKA (TOGETHER WITH MADAN MOHAN MOHANKA, THE "PROMOTER SELLING SHAREHOLDERS") AND UP TO 9,691,890 EQUITY SHARES AGGREGATING UP TO ₹ [·] MILLION BY WAGNER LIMITED ("INVESTOR SELLING SHAREHOLDER") (AND TOGETHER WITH THE PROMOTER SELLING SHAREHOLDERS, THE "SELLING SHAREHOLDERS") AND SUCH EQUITY SHARES OFFERED BY THE SELLING SHAREHOLDERS, THE "OFFERED SHARES"). THE OFFER WOULD CONSTITUTE [·] % OF OUR POST-OFFER PAID-UP EQUITY SHARE CAPITAL.

THE FACE VALUE OF EQUITY SHARES IS ₹10 EACH. THE OFFER PRICE IS [·] TIMES THE FACE VALUE OF THE EQUITY SHARES. THE PRICE BAND AND THE MINIMUM BID LOT WILL BE DECIDED BY OUR COMPANY AND THE SELLING SHAREHOLDERS, IN CONSULTATION WITH THE BOOK RUNNING LEAD MANAGERS (THE "BRLMs") AND WILL BE ADVERTISED IN ALL EDITIONS OF FINANCIAL EXPRESS (A WIDELY CIRCULATED ENGLISH NATIONAL DAILY NEWSPAPER), ALL EDITIONS OF JANSATTA (A WIDELY CIRCULATED HINDI NATIONAL DAILY NEWSPAPER) AND ALL EDITIONS OF ARTHIK LIPI (A WIDELY CIRCULATED BENGALI NATIONAL DAILY NEWSPAPER, BENGALI BEING THE REGIONAL LANGUAGE IN WEST BENGAL WHERE OUR REGISTERED OFFICE IS SITUATED), EACH WITH WIDE CIRCULATION, AT LEAST TWO WORKING DAYS PRIOR TO THE BID/OFFER OPENING DATE AND SHALL BE MADE AVAILABLE TO BSE LIMITED ("BSE") AND THE NATIONAL STOCK EXCHANGE OF INDIA LIMITED (THE "NSE", AND TOGETHER WITH BSE, THE "STOCK EXCHANGES") FOR THE PURPOSES OF UPLOADING ON THEIR RESPECTIVE WEBSITES.

In case of a revision in the Price Band, the Bid/Offer Period will be extended for at least three additional Working Days after revision of the Price Band, subject to the Bid/Offer Period not exceeding a total of 10 Working Days. In cases of force majeure, banking strike or similar circumstances, our Company may, in consultation with the BRLMs, for reasons to be recorded in writing, extend the Bid/Offer Period for a minimum of three Working Days, subject to the Bid/Offer Period not exceeding 10 Working Days. Any revision in the Price Band and the revised Bid/Offer Period, if applicable, will be widely disseminated by notification to the Stock Exchanges, by issuing a press release, and also by indicating the change on the websites of the BRLMs, and at the terminals of the members of the Syndicate and by an intimation to the Designated Intermediaries and the Sponsor Bank.

The Offer is being made in terms of Rule 19(2)(b) of the Securities Contracts (Regulation) Rules, 1957, as amended, read with Regulation 31 of the Securities and Exchange Board of India (Issue of Capital and Disclosure Requirements) Regulations, 2018, as amended ("SEBI ICDR Regulations"). The Offer is being made through the Book Building Process, in compliance with Regulation 6(1) of the SEBI ICDR Regulations, wherein not more than 50% of the Offer shall be available for allocation on a proportionate basis to Qualified Institutional Buyers (the "QIBs") (the "QIB Category"), provided that our Company and the Selling Shareholders in consultation with the BRLMs, may allocate up to 60% of the QIB Category to Anchor Investors, on a discretionary basis (the "Anchor Investor Portion"). One-third of the Anchor Investor Portion shall be reserved for domestic Mutual Funds, subject to valid Bids being received from domestic Mutual Funds at or above the price at which allocation is made to Anchor Investors. 5% of the QIB Category (excluding the Anchor Investor Portion) shall be available for allocation on a proportionate basis to Mutual Funds only, and the remainder of the QIB Category shall be available for allocation on a proportionate basis to all QIBs, including Mutual Funds, subject to valid Bids being received from them at or above the Offer Price. Further, not less than 15% of the Offer shall be available for allocation on a proportionate basis to Non-Institutional Investors and not less than 35% of the Offer will be available for allocation to Retail Individual Investors, in accordance with the SEBI ICDR Regulations, subject to valid Bids being received at or above the Offer Price. All Bidders, other than the Anchor Investors, are mandatorily required to participate in this Offer only through an Application Supported by Blocked Amount ("ASBA") process, providing details of their respective bank accounts (including UPI ID for Retail Individual Investors using UPI Mechanism) in which the Bid amount will be blocked by the Self Certified Syndicate Banks or the Sponsor Bank. The Anchor Investors are not permitted to participate in the Anchor Investor Portion through the ASBA process. For further details, see "Offer Procedure" beginning on page 380.

### RISKS IN RELATION TO THE FIRST OFFER

This being the first public issue of the Equity Shares, there has been no formal market for the Equity Shares. The face value of the Equity Shares is ₹10 each. The Floor Price, the Cap Price and the Offer Price (as determined by our Company and the Selling Shareholders, in consultation with the BRLMs, in accordance with the SEBI ICDR Regulations, and as stated in "Basis for Offer Price" beginning on page 98 should not be taken to be indicative of the market price of the Equity Shares after the Equity Shares are listed. No assurance can be given regarding an active and/or sustained trading in the Equity Shares or regarding the price at which the Equity Shares will be traded after listing.

### GENERAL RISKS

Investments in equity and equity-related securities involve a degree of risk and investors should not invest any funds in the Offer unless they can afford to take the risk of losing their entire investment. Investors are advised to read the risk factors carefully before taking an investment decision in the Offer. For taking an investment decision, investors must rely on their own examination of our Company and the Offer including the risks involved. The Equity Shares in the Offer have not been recommended or approved by the Securities and Exchange Board of India ("SEBI"), nor does SEBI guarantee the accuracy or adequacy of the contents of this Red Herring Prospectus. Specific attention of the investors is invited to "Risk Factors" beginning on page 23.

### ISSUER'S AND SELLING SHAREHOLDERS' ABSOLUTE RESPONSIBILITY

Our Company, having made all reasonable inquiries, accepts responsibility for and confirms that this Red Herring Prospectus contains all information with regard to our Company and the Offer, which is material in the context of the Offer, that the information contained in this Red Herring Prospectus is true and correct in all material aspects and is not misleading in any material respect, that the opinions and intentions expressed herein are honestly held and that there are no other facts, the omission of which makes this Red Herring Prospectus as a whole or any of such information or the expression of any such opinions or intentions, misleading in any material respect.

Further, each Selling Shareholder severally and not jointly accepts responsibility for and confirms only the information given expressly by such Selling Shareholder relating to itself and its respective portion of Offered Shares contained in this Red Herring Prospectus as true and correct in all material aspects and not misleading in any material respect. Each Selling Shareholder, severally and not jointly, does not assume any responsibility for any other statements, including without limitation, any and all of the statements made by or in relation to our Company or the Selling Shareholders in this Red Herring Prospectus.

### LISTING

The Equity Shares issued through the Red Herring Prospectus are proposed to be listed on the Stock Exchanges. We have received in-principle approvals from BSE and NSE for the listing of the Equity Shares pursuant to their letters dated September 2, 2021 and September 8, 2021, respectively. For the purposes of this Offer, NSE is the Designated Stock Exchange. A signed copy of the Red Herring Prospectus and the Prospectus shall be delivered for filing with the RoC in accordance with Section 26(4) of the Companies Act 2013. For further information on the material contracts and documents available for inspection from the date of the Red Herring Prospectus up to the Bid/Offer Closing Date, see "Material Contracts and Documents for Inspection" beginning on page 413.

### BOOK RUNNING LEAD MANAGERS

### REGISTRAR TO THE OFFER

<p><b>Axis Capital Limited</b>                  1<sup>st</sup> Floor, Axis House                  C-2, Wadia International Centre P. B. Marg, Worli                  Mumbai 400 025                  Maharashtra, India                  Tel: +91 22 4325 2183                  E-mail: tega.ipo@axiscap.in                  Website: www.axiscapital.co.in                  Investor grievance E-mail: complaints@axiscap.in                  Contact Person: Pratik Pednekar                  SEBI Registration No: INM000012029</p>	<p><b>JM Financial Limited</b>                  7<sup>th</sup> Floor, Chergy                  Appasaheb Marathe Marg, Prabhadevi                  Mumbai 400 025                  Maharashtra, India                  Tel: + 91 22 6630 3030                  E-mail: tega.ipo@jmfl.com                  Website: www.jmfl.com                  Investor grievance E-mail: grievance.ibd@jmfl.com                  Contact Person: Prachee Dhuri                  SEBI Registration No.: INM000010361</p>	<p><b>Link Intime India Private Limited</b>                  C-101, 1<sup>st</sup> Floor, 247 Park                  L.B.S. Marg, Vikhroli West,                  Mumbai 400 083                  Maharashtra, India                  Tel: +91 22 4918 6200                  E-mail: tega.ipo@linkintime.co.in                  Website: www.linkintime.co.in                  Investor grievance E-mail: tega.ipo@linkintime.co.in                  Contact Person: Shanti Gopalkrishnan                  SEBI Registration No: INR000004058</p>
--	---	--

BID/OFFER OPENS ON December 1, 2021<sup>(1)</sup>

### BID/OFFER PERIOD

BID/OFFER CLOSES ON December 3, 2021

(1) Our Company and the Selling Shareholders, in consultation with the BRLMs, may consider participation by Anchor Investors, in accordance with the SEBI ICDR Regulations. The Anchor Investor Bidding Date shall be one Working Day prior to the Bid/Offer Opening Date.

*(This page is intentionally left blank)*

## TABLE OF CONTENTS

<b>SECTION I – GENERAL</b> .....	<b>1</b>
<b>DEFINITIONS AND ABBREVIATIONS</b> .....	<b>1</b>
<b>CERTAIN CONVENTIONS, USE OF FINANCIAL INFORMATION AND MARKET DATA AND CURRENCY OF PRESENTATION</b> .....	<b>12</b>
<b>FORWARD-LOOKING STATEMENTS</b> .....	<b>16</b>
<b>SUMMARY OF THE OFFER DOCUMENT</b> .....	<b>18</b>
<b>SECTION II - RISK FACTORS</b> .....	<b>23</b>
<b>SECTION III – INTRODUCTION</b> .....	<b>64</b>
<b>THE OFFER</b> .....	<b>64</b>
<b>SUMMARY FINANCIAL INFORMATION</b> .....	<b>66</b>
<b>GENERAL INFORMATION</b> .....	<b>70</b>
<b>CAPITAL STRUCTURE</b> .....	<b>79</b>
<b>OBJECTS OF THE OFFER</b> .....	<b>98</b>
<b>BASIS FOR OFFER PRICE</b> .....	<b>100</b>
<b>STATEMENT OF POSSIBLE TAX BENEFITS</b> .....	<b>103</b>
<b>SECTION IV: ABOUT THE COMPANY</b> .....	<b>108</b>
<b>INDUSTRY OVERVIEW</b> .....	<b>108</b>
<b>BUSINESS</b> .....	<b>141</b>
<b>KEY REGULATIONS AND POLICIES IN INDIA</b> .....	<b>167</b>
<b>HISTORY AND CERTAIN CORPORATE MATTERS</b> .....	<b>170</b>
<b>OUR MANAGEMENT</b> .....	<b>180</b>
<b>PROMOTER AND PROMOTER GROUP</b> .....	<b>199</b>
<b>GROUP COMPANIES</b> .....	<b>204</b>
<b>DIVIDEND POLICY</b> .....	<b>206</b>
<b>SECTION V – FINANCIAL INFORMATION</b> .....	<b>207</b>
<b>RESTATED CONSOLIDATED FINANCIAL INFORMATION</b> .....	<b>207</b>
<b>OTHER FINANCIAL INFORMATION</b> .....	<b>313</b>
<b>FINANCIAL INDEBTEDNESS</b> .....	<b>314</b>
<b>CAPITALIZATION STATEMENT</b> .....	<b>317</b>
<b>MANAGEMENT’S DISCUSSION AND ANALYSIS OF FINANCIAL CONDITION AND RESULTS OF OPERATIONS</b> .....	<b>318</b>
<b>SECTION VI: LEGAL AND OTHER INFORMATION</b> .....	<b>355</b>
<b>OUTSTANDING LITIGATION AND OTHER MATERIAL DEVELOPMENTS</b> .....	<b>355</b>
<b>GOVERNMENT AND OTHER APPROVALS</b> .....	<b>359</b>
<b>OTHER REGULATORY AND STATUTORY DISCLOSURES</b> .....	<b>362</b>
<b>SECTION VII – OFFER RELATED INFORMATION</b> .....	<b>372</b>
<b>TERMS OF THE OFFER</b> .....	<b>372</b>
<b>OFFER STRUCTURE</b> .....	<b>377</b>
<b>OFFER PROCEDURE</b> .....	<b>380</b>
<b>RESTRICTION ON FOREIGN OWNERSHIP OF INDIAN SECURITIES</b> .....	<b>397</b>
<b>SECTION VIII – MAIN PROVISIONS OF ARTICLES OF ASSOCIATION</b> .....	<b>398</b>
<b>SECTION IX – OTHER INFORMATION</b> .....	<b>413</b>
<b>MATERIAL CONTRACTS AND DOCUMENTS FOR INSPECTION</b> .....	<b>413</b>
<b>DECLARATION</b> .....	<b>415</b>

## SECTION I – GENERAL

### DEFINITIONS AND ABBREVIATIONS

Unless the context otherwise indicates or implies, the following terms shall have the meanings provided below in this Red Herring Prospectus, and references to any statute or regulations or policies will include any amendments or re-enactments thereto, from time to time and any reference to a statutory provision shall include any subordinate legislation made from time to time under that provision.

Notwithstanding the foregoing, terms in the sections “Statement of Tax Benefits”, “Industry Overview”, “Key Regulations and Policies in India”, “Financial Information”, “Outstanding Litigation and Other Material Developments” and “Main Provision of Articles of Association” will have the meaning ascribed to such terms in these respective sections.

In case of any inconsistency between the definitions given below and the definitions contained in the General Information Document (as defined below), the definitions given below shall prevail. The words and expressions used but not defined in this Red Herring Prospectus will have the same meaning as assigned to such terms under the Companies Act 2013, the SEBI Act, the SEBI ICDR Regulations, the SCRA, the Depositories Act and the rules and regulations made thereunder.

#### General Terms

Term	Description
“the Company”/ “our Company”/ “the Issuer”	Tega Industries Limited, incorporated under the Companies Act, 1956, in India as a public limited company with its Registered Office at 147, Block-G, New Alipore, Kolkata 700 053, West Bengal, India
“we”/ “us”/ “our”	Unless the context otherwise requires, our Company together with our Subsidiaries and our Joint Venture, on a consolidated basis

#### Company Related Terms

Term	Description
“AoA”/ “Articles of Association”	The articles of association of our Company, as amended
Audit Committee	The audit committee of our Board, as described in “ <i>Our Management</i> ” beginning on page 180
“Auditors”/ “Statutory Auditors”	The statutory auditors of our Company, being Price Waterhouse & Co Bangalore LLP
“Board”/ “Board of Directors”	The board of directors of our Company, or a duly constituted committee thereof
“Chief Financial Officer”/ “CFO”	Manoj Kumar Agarwal, the chief financial officer of our Company
CCPP	Compulsorily Convertible Participatory Preference Shares of our Company of face value of ₹ 10 each
Chairman	Madan Mohan Mohanka, chairman of our Company
Compliance Officer	Sudipta Bhowal, the company secretary and compliance officer of our Company
CSR Committee	The corporate social responsibility committee of our Board, as described in “ <i>Our Management</i> ” beginning on page 180
Corporate Office	The office of our Company located at Office Space No. 807, 8 <sup>th</sup> Floor, Godrej Waterside-Tower II, DP-5, Bidhannagar, Salt Lake, Sector V, Kolkata 700 091, West Bengal, India
Director(s)	The director(s) on our Board
Equity Shares	The equity shares of our Company of face value of ₹ 10 each
Executive Director	Executive Director(s) on our Board
ESOP 2011	Employee Stock Option Plan, 2011, of our Company
ESOP 2021	Tega Industries Limited Employee Stock Option Plan, 2021, of our Company
ESOP Schemes	ESOP 2011 and ESOP 2021
“Frost & Sullivan Report”/ “F&S Report”	Report titled “ <i>Global Market Assessment – Select Mineral Processing Equipment</i> ” dated October 12, 2021, issued by Frost & Sullivan, also available at the following weblink <a href="https://www.tegaindustries.com/tega-investors/#indreport">https://www.tegaindustries.com/tega-investors/#indreport</a>
Group Companies	In terms of SEBI ICDR Regulations, the term “group companies” includes companies (other than our Promoter and Subsidiaries) with which there were related party transactions as disclosed in the Restated Consolidated Financial Information as covered under the applicable accounting standards, being Ind AS 24 and such other companies as considered



Term	Description
	material by our Board, in terms of the Materiality Policy and as set forth in “ <i>Group Companies</i> ” beginning on page 204
Holding Company	NFSPL, the holding company of our Company
Hosch India	Hosch Equipment (India) Ltd.
Independent Director(s)	The independent Director(s) on our Board
IPO Committee	The IPO committee of our Board formed pursuant to resolution dated April 30, 2021 approved by our Board
Joint Venture	Hosch India, a joint venture of our Company
“Hosch JVA”	Joint venture agreement dated November 12, 1991 between Hosch (G.B.) Limited, England and Madan Mohan Mohanka read with the Share purchase agreement dated May 29, 2010 between Madan Mohan Mohanka and Company
“KMP”/ “Key Managerial Personnel”	Key managerial personnel of our Company in terms of Regulation 2(1)(bb) of the SEBI ICDR Regulations and Section 2(51) of the Companies Act 2013 and as described in “ <i>Our Management - Key Managerial Personnel</i> ” on page 196
Losugen	Losugen Pty. Ltd., one of our Subsidiaries
Managing Director	Mehul Mohanka, managing director of our Company
Materiality Policy	The policy adopted by our Board at its meeting held on August 3, 2021, as amended on November 10, 2021 for identification of Group Companies, material outstanding litigation and material dues outstanding to creditors, pursuant to the disclosure requirements under the SEBI ICDR Regulations
Material Subsidiaries	Tega Chile, Tega Africa, Tega Holdings Pte Ltd and Losugen, material subsidiaries of our Company in accordance with the provisions of SEBI ICDR Regulations
“MoA”/ “Memorandum of Association”	The memorandum of association of our Company, as amended
NFSPL	Nihal Fiscal Services Private Limited
Nomination and Remuneration Committee	The nomination and remuneration committee of our Board, as described in “ <i>Our Management</i> ” beginning on page 180
Promoters	Madan Mohan Mohanka, Manju Mohanka, Manish Mohanka, Mehul Mohanka and NFSPL
Promoter Group	Persons and entities constituting the promoter group of our Company, pursuant to Regulation 2(1)(pp) of the SEBI ICDR Regulations, as disclosed in “ <i>Promoter and Promoter Group-Promoter Group</i> ” beginning on page 199
Registered Office	The registered office of our Company located at 147, Block-G, New Alipore, Kolkata 700 053, West Bengal, India
“Registrar of Companies”/ “RoC”	Registrar of Companies, West Bengal at Kolkata
Restated Consolidated Financial Information	<p>The restated consolidated financial information of our Company and our Subsidiaries, along with our joint venture comprises of the Restated Consolidated Statement of Assets and Liabilities as at June 30, 2021, March 31, 2021, March 31, 2020 and March 31, 2019, the Restated Consolidated Statement of Profit and Loss, the Restated Consolidated Statement of Changes in Equity and Restated Consolidated Statement of Cash Flows for the three months period ended June 30, 2021 and for the years ended March 31, 2021, March 31, 2020 and March 31, 2019, Notes to the Restated Consolidated Financial Information and Statement of Adjustments to the Audited Special Purpose Interim Consolidated Financial Statements as at and for the three months period ended June 30, 2021 and Audited Consolidated Financial Statements as at and for the years ended March 31, 2021, March 31, 2020 and March 31, 2019.</p> <p>The Restated Consolidated Financial Information have been prepared in accordance with the requirements of Section 26 of Companies Act, Paragraph (A) of Clause 11 (I) of Part A of Schedule VI of the SEBI ICDR Regulations and the Guidance Note on Reports in Company Prospectuses (Revised 2019) issued by the ICAI, as included in “<i>Financial Information</i>” beginning on page 207</p>
Risk Management Committee	The risk management committee of our Board, as described in “ <i>Our Management</i> ” beginning on page 180
Shareholders	The holders of the Equity Shares from time to time
“Scheme of Amalgamation”/ “Scheme”	The scheme of amalgamation dated July 17, 2021 filed before the National Company Law Tribunal, Kolkata by NFSPL, Marudhar and MM Group Holdings Private Limited
SSPA	Share Subscription and Share Purchase Agreement dated April 29, 2011 entered into by and among our Company, Wagner Limited and Madan Mohan Mohanka, Manish Mohanka, Mehul Mohanka, Madan Mohan Mohanka (HUF), Mehul Mohanka (HUF), NFSPL, Marudhar Food & Credit Limited
“Shareholders’ Agreement”/ “SHA”	Shareholders’ Agreement dated April 29, 2011 entered into by and among our Company, Wagner Limited and Madan Mohan Mohanka, Manish Mohanka, Mehul Mohanka, Madan Mohan Mohanka (HUF), Mehul Mohanka (HUF), NFSPL, Marudhar Food & Credit Limited (“ <i>Parties</i> ”) read with the amendment agreements entered into by and among the Parties

Term		Description
		dated September 3, 2018 and July 10, 2020, August 2, 2021 and the SHA Amendment Agreement
SHA Agreement	Amendment	Amendment agreement dated August 7, 2021 to the SHA entered into by and among our Company, Wagner Limited and our Promoters
Stakeholders Committee	Relationship	The stakeholders relationship committee of our Board, as described in “ <i>Our Management</i> ” beginning on page 180
Subsidiaries		The subsidiaries of our Company, including step-down subsidiaries of our Company, in accordance with the provisions of the Companies Act, 2013. For further details, please see “ <i>History and Certain Corporate Matters – Our Subsidiaries</i> ” on page 173
Tega Africa		Tega Industries Africa (Pty) Ltd, one of our Subsidiaries
Tega Chile		Tega Industries Chile SPA, one of our Subsidiaries
Wagner		Wagner Limited

## Offer Related Terms

Term		Description
Abridged Prospectus		Abridged prospectus means a memorandum containing such salient features of a prospectus as may be specified by SEBI in this behalf
Acknowledgement Slip		The slip or document to be issued by a Designated Intermediary to a Bidder as proof of registration of the Bid cum Application Form
Allotment Advice		The note or advice or intimation of Allotment, sent to each Bidder who has been or is to be Allotted the Equity Shares after approval of the Basis of Allotment by the Designated Stock Exchange
“Allotted”/ “Allot”	“Allotment”/	Unless the context otherwise requires, the allotment of the Equity Shares pursuant to the transfer of the Offered Shares pursuant to the Offer for Sale to successful Bidders
Allottee		A successful Bidder to whom the Equity Shares are Allotted
Anchor Escrow Accounts		Accounts opened with Escrow Collection Bank and in whose favour the Anchor Investors will transfer money through direct credit, NEFT, RTGS or NACH in respect of the Bid Amount when submitting a Bid
Anchor Investor		A QIB, who applies under the Anchor Investor Portion in accordance with the requirements specified in the SEBI ICDR Regulations and this Red Herring Prospectus and who has Bid for an amount of at least ₹100 million
Anchor Investor Allocation Prices		The price at which allocation of the Equity Shares is done to the Anchor Investors in terms of the Red Herring Prospectus. The Anchor Investor Allocation Price shall be determined by our Company and the Selling Shareholder, in consultation with the BRLMs during the Anchor Investor Bid / Offer Period.
Anchor Investor Application Form		Form used by an Anchor Investor to make a Bid in the Anchor Investor Portion and which will be considered as an application for Allotment in terms of this Red Herring Prospectus and Prospectus
“Anchor Investor Bid”/ “Offer Period”		The day being one Working Day prior to the Bid/ Offer Opening Date on which Bids by Anchor Investors shall be submitted and allocation to Anchor Investors shall be completed
Anchor Investor Bidding Date		The date one Working Day prior to the Bid/Offer Opening Date on which Bids by Anchor Investors shall be submitted prior to and after which the BRLMs will not accept any bids from Anchor investors, and allocation to the Anchor Investors shall be completed
Anchor Investor Offer Price		The final price at which the Equity Shares will be Allotted to Anchor Investors in terms of this Red Herring Prospectus and the Prospectus, which will be a price equal to or higher than the Offer Price but not higher than the Cap Price. The Anchor Investor Offer Price will be decided by our Company and the Selling Shareholders, in consultation with the BRLMs
Anchor Investor Portion		Up to 60% of the QIB Category, which may be allocated by our Company and the Selling Shareholders, in consultation with the BRLMs, to Anchor Investors, on a discretionary basis, in accordance with SEBI ICDR Regulations. One-third of the Anchor Investor Portion is reserved for domestic Mutual Funds, subject to valid Bids being received from domestic Mutual Funds at or above the Anchor Investor Allocation Price. In the event of under-subscription, or non-allocation in the Anchor Investor Portion, the balance Equity Shares shall be added to the QIB Category
“Application Supported by Blocked Amount”/ “ASBA”		An application (whether physical or electronic) by a Bidder (other than Anchor Investors) to make a Bid authorizing the relevant SCSB to block the Bid Amount in the relevant ASBA Account and will include applications made by RIIs using the UPI Mechanism where the Bid Amount will be blocked by SCSB upon acceptance of UPI Mandate Request
ASBA Account		A bank account maintained with an SCSB and specified in the Bid cum Application Form which will be blocked by such SCSB to the extent of the appropriate Bid Amount in relation to a Bid by a Bidder (other than a Bid by an Anchor Investor) and will include amounts blocked by SCSB upon acceptance of UPI Mandate Request by RIIs using the UPI Mechanism
ASBA Bidders		All Bidders except Anchor Investors

<b>Term</b>	<b>Description</b>
ASBA Form	An application form, whether physical or electronic, used by Bidders Bidding through the ASBA process, which will be considered as the application for Allotment in terms of this Red Herring Prospectus and the Prospectus
Axis	Axis Capital Limited
Banker(s) to the Offer	The Escrow Collection Bank(s), Refund Bank(s), Public Offer Account Bank(s) and the Sponsor Bank, as the case may be
Basis of Allotment	The basis on which the Equity Shares will be Allotted to successful Bidders under the Offer, as described in “ <b>Offer Procedure</b> ” on beginning page 380
Bid	An indication to make an offer during the Bid/Offer Period by a Bidder (other than an Anchor Investor), or on the Anchor Investor Bidding Date by an Anchor Investor, pursuant to submission of a Bid cum Application Form, to subscribe for or purchase our Equity Shares at a price within the Price Band, including all revisions and modifications thereto, to the extent permissible under the SEBI ICDR Regulations, in terms of this Red Herring Prospectus and the Bid cum Application Form. The term “Bidding” shall be construed accordingly
Bid Amount	The highest value of the optional Bids as indicated in the Bid cum Application Form and payable by the Bidder or as blocked in the ASBA Account of the Bidder, as the case may be, upon submission of the Bid in the Offer
Bid cum Application Form	The form in terms of which the Bidder shall make a Bid, including ASBA Form, and which shall be considered as the application for the Allotment pursuant to the terms of this Red Herring Prospectus and the Prospectus
Bid Lot	[•] Equity Shares
“Bid”/ “Offer Closing Date”	Except in relation to Anchor Investors, the date after which the Designated Intermediaries shall not accept any Bids for the Offer, being December 3, 2021, which shall be published in all editions of Financial Express (a widely circulated English national daily newspaper), all editions of Jansatta (a widely circulated Hindi national daily newspaper) and all editions of Arthik Lipi (a widely circulated Bengali regional daily newspaper, Bengali being the regional language in West Bengal, where our Registered Office is located) and in case of any revisions, the extended Bid/Offer Closing Date shall also be notified on the websites and terminals of the Syndicate Members, as required under the SEBI ICDR Regulations and also intimated to the Designated Intermediaries
“Bid”/ “Offer Opening Date”	Except in relation to Anchor Investors, the date on which the Designated Intermediaries shall start accepting Bids for the Offer, being December 1, 2021, which shall be published in all editions of Financial Express (a widely circulated English national daily newspaper), all editions of Jansatta (a widely circulated Hindi national daily newspaper) and all editions of Arthik Lipi (a widely circulated Bengali regional daily newspaper, Bengali being the regional language where our Registered Office is located) and in case of any revisions, the extended Bid/Offer Closing Date shall also be notified on the websites and terminals of the Syndicate Members and also intimated to the Designated Intermediaries, as required under the SEBI ICDR Regulations
“Bid”/ “Offer Period”	Except in relation to Bids received from Anchor Investors, the period between the Bid/Offer Opening Date and the Bid/Offer Closing Date, inclusive of both days during which prospective Bidders (excluding Anchor Investors) can submit their Bids, including any revisions thereof in accordance with the SEBI ICDR Regulations and the terms of this Red Herring Prospectus. Provided, however, that the Bidding shall be kept open for a minimum of three Working Days for all categories of Bidders, other than Anchor Investors. In cases of force majeure, banking strike or similar circumstances, our Company may, for reasons to be recorded in writing, extend the Bid / Offer Period for a minimum of three Working Days, subject to the Bid/ Offer Period not exceeding 10 Working Days
Bidder	Any prospective investor who makes a Bid pursuant to the terms of this Red Herring Prospectus and the Bid cum Application Form and unless otherwise stated or implied, includes an Anchor Investor
Bidding Centres	Centres at which the Designated Intermediaries shall accept the Bid cum Application Forms, being the Designated SCSB Branch for SCSBs, Specified Locations for the Syndicate, Broker Centres for Registered Brokers, Designated RTA Locations for RTAs and Designated CDP Locations for CDPs
Book Building Process	The book building process as described in Part A of Schedule XIII of the SEBI ICDR Regulations, in terms of which the Offer is being made
“Book Running Lead Managers”/ “BRLMs”	Axis and JM Financial
Broker Centres	Broker centres of the Registered Brokers, where Bidders (other than Anchor Investors) can submit the Bid cum Application Forms. The details of such Broker Centres, along with the names and contact details of the Registered Brokers are available on the respective websites of the Stock Exchanges
“CAN”/ “Confirmation of Allocation Note”	Notice or intimation of allocation of the Equity Shares sent to Anchor Investors, who have been allocated the Equity Shares, after the Anchor Investor Bidding Date

<b>Term</b>	<b>Description</b>
Cap Price	The higher end of the Price Band above which the Offer Price and Anchor Investor Offer Price will not be finalized and above which no Bids will be accepted, including any revisions thereof
Cash Escrow and Sponsor Bank Agreement	The agreement dated November 23, 2021 entered into among our Company, the Selling Shareholders, the Registrar to the Offer, the BRLMs, the Syndicate Members, the Banker(s) to the Offer and the Sponsor Bank for collection of the Bid Amounts, and where applicable remitting refunds, if any, to the Anchor Investors, on the terms and conditions thereof
Client ID	Client identification number of the Bidder's beneficiary account
"Collecting Depository Participants"/ "CDPs"	The depository participants, as defined under the Depositories Act, 1996 and registered under Section 12 (1A) of the SEBI Act and who are eligible to procure Bids at the Designated CDP Locations in terms of circular no. CIR/CFD/POLICYCELL/11/2015 dated November 10, 2015 and the SEBI UPI Circulars, issued by SEBI
Cut-off Price	The Offer Price, finalised by our Company and the Selling Shareholders, in consultation with the BRLMs, which shall be any price within the Price Band. Only Retail Individual Investors are entitled to Bid at the Cut-off Price. QIBs (including Anchor Investors) and Non-Institutional Investors are not entitled to Bid at the Cut-off Price
Demographic Details	The details of the Bidders including the Bidders' address, names of the Bidders' father/husband, investor status, occupation, PAN, bank account details and UPI ID, wherever applicable
Designated Branches	Such branches of the SCSBs which may collect the Bid cum Application Form used by Bidders (other than Anchor Investors), a list of which is available at the website of the SEBI ( <a href="http://www.sebi.gov.in/sebiweb/other/OtherAction.do?doRecognised=yes">www.sebi.gov.in/sebiweb/other/OtherAction.do?doRecognised=yes</a> ) and updated from time to time
Designated CDP Locations	Such centres of the Collecting Depository Participants where Bidders (other than Anchor Investors) can submit the Bid cum Application Forms. The details of such Designated CDP Locations, along with the names and contact details of the CDPs are available on the respective websites of the Stock Exchanges and updated from time to time
Designated Date	The date on which the funds from the Anchor Escrow Accounts are transferred to the Public Offer Account or the Refund Account(s), as appropriate, and the relevant amounts blocked by the SCSBs are transferred from the ASBA Accounts, to the Public Offer Account and/or are unblocked, as applicable, in terms of this Red Herring Prospectus, after the Prospectus is filed with the RoC and finalization of basis of allotment with the Designated Stock Exchange
Designated Intermediaries	In relation to ASBA Forms submitted by RIBs (not using the UPI mechanism) by authorising an SCSB to block the Bid Amount in the ASBA Account, Designated Intermediaries shall mean SCSBs. In relation to ASBA Forms submitted by RIBs where the Bid Amount will be blocked upon acceptance of UPI Mandate Request by such RIB using the UPI Mechanism, Designated Intermediaries shall mean Syndicate, sub-syndicate/agents, Registered Brokers, CDPs, SCSBs and RTAs. In relation to ASBA Forms submitted by QIBs and Non-Institutional Bidders, Designated Intermediaries shall mean Syndicate, Sub-Syndicate/ agents, SCSBs, Registered Brokers, the CDPs and RTAs
Designated RTA Locations	Such centres of the RTAs where Bidders (other than Anchor Investors) can submit the Bid cum Application Forms. The details of such Designated RTA Locations, along with the names and contact details of the RTAs are available on the respective websites of the Stock Exchanges ( <a href="http://www.nseindia.com">www.nseindia.com</a> and <a href="http://www.bseindia.com">www.bseindia.com</a> ) and updated from time to time
Designated Stock Exchange	NSE
"Draft Red Herring Prospectus"/ "DRHP"	The draft red herring prospectus dated August 17, 2021, issued in accordance with the SEBI ICDR Regulations, which did not contain complete particulars of the price at which our Equity Shares will be Allotted and the size of the Offer
Eligible FPIs	FPIs that are eligible to participate in this Offer in terms of applicable laws, other than individuals, corporate bodies and family offices
Eligible NRI	A non-resident Indian, resident in a jurisdiction outside India where it is not unlawful to make an offer or invitation under the Offer and in relation to whom this Red Herring Prospectus constitutes an invitation to subscribe for the Equity Shares
First Bidder	The Bidder whose name appears first in the Bid cum Application Form or the Revision Form and in case of joint Bidders, whose name appears as the first holder of the beneficiary account held in joint names
Floor Price	The lower end of the Price Band, and any revisions thereof, at or above which the Offer Price and the Anchor Investor Offer Price will be finalized and below which no Bids will be accepted and which shall not be less than the face value of the Equity Shares
General Information Document	The General Information Document for investing in public issues prepared and issued in accordance with the circular no. SEBI / HO / CFD / DIL1 / CIR / P / 2020 / 37 dated March 17, 2020 and the circular no. SEBI / HO / CFD / DIL2 / CIR / P / 2020 / 50 dated March 30, 2020, as amended by SEBI from time to time The General Information Document shall be available on the websites of the Stock Exchanges and the BRLMs

Term	Description
Investor Selling Shareholder	Wagner Limited
IPO	Initial public offering
JM Financial	JM Financial Limited
Maximum RII Allottees	The maximum number of RIIs who can be allotted the minimum Bid Lot. This is computed by dividing the total number of Equity Shares available for Allotment to RIIs by the minimum Bid Lot
Minimum Promoters' Contribution	Aggregate of 20% of the fully diluted post-Offer Equity Share capital of our Company held by our Promoters which shall be provided towards minimum promoter's contribution and locked-in for a period of three years from the date of Allotment
Mutual Fund Portion	5% of the QIB Category (other than the Anchor Investor Portion) or 136,695 Equity Shares which shall be available for allocation to Mutual Funds only, on a proportionate basis, subject to valid Bids being received at or above the Offer Price
Net QIB Portion	The portion of the QIB Portion less the number of Equity Shares Allocated to the Anchor Investors
Non-Institutional Category	The portion of the Offer, being not less than 15% of the Offer or 2,050,422 Equity Shares, available for allocation on a proportionate basis to Non-Institutional Investors subject to valid Bids being received at or above the Offer Price
"Non-Institutional Investors"/ "NIIs"	All Bidders that are not QIBs (including Anchor Investors) and Retail Individual Investors who have Bid for Equity Shares for an amount of more than ₹ 200,000 (but not including NRIs other than Eligible NRIs)
Offer	The initial public offer of Equity Shares comprising the Offer for Sale. The initial public offer of up to 13,669,478 Equity Shares of face value of ₹ 10 each for cash at a price of ₹ [•] per Equity Shares aggregating up to ₹ [•] million through an Offer for Sale by the Selling Shareholders.
Offer Agreement	The agreement dated August 17, 2021, as amended by the amendment to the offer agreement dated November 10, 2021, entered into amongst our Company, the Selling Shareholders and the BRLMs, pursuant to which certain arrangements are agreed to in relation to the Offer
Offer for Sale	Offer of up to 13,669,478 Equity Shares to be offered for sale by the Selling Shareholders pursuant to the Offer in terms of this Red Herring Prospectus and the Prospectus. For further information, see " <i>The Offer</i> " beginning on page 64
Offer Price	The final price at which Equity Shares will be Allotted to the successful Bidders (other than Anchor Investors), as determined in accordance with the Book Building Process and determined by our Company and the Selling Shareholders, in consultation with the BRLMs in terms of this Red Herring Prospectus on the Pricing Date. Equity Shares will be Allotted to Anchor Investors at the Anchor Investor Offer Price in terms of this Red Herring Prospectus on the Pricing Date.
Offered Shares	Up to 13,669,478 Equity Shares, offered for sale pursuant to the Offer for Sale, comprising up to 3,314,657 Equity Shares by Madan Mohan Mohanka, up to 662,931 Equity Shares by Manish Mohanka and up to 9,691,890 Equity Shares by Wagner
Price Band	Price band of the Floor Price of ₹ [•] and a Cap Price of ₹ [•], including any revisions thereof. The Price Band and the minimum Bid Lot size for the Offer will be decided by our Company and the Selling Shareholders, in consultation with the BRLMs, and advertised in all editions of Financial Express (a widely circulated English national daily newspaper), all editions of Jansatta (a widely circulated Hindi national daily newspaper) and all editions of Arthik Lipi (a widely circulated Bengali regional daily newspaper, Bengali being the regional language in West Bengal, where our Registered Office is located) at least two Working Days prior to the Bid/Offer Opening Date, with the relevant financial ratios calculated at the Floor Price and at the Cap Price and shall be made available to the Stock Exchanges for the purpose of uploading on their websites
Pricing Date	The date on which our Company and the Selling Shareholders, in consultation with the BRLMs, shall finalize the Offer Price
Promoter Selling Shareholder(s)	Collectively, Madan Mohan Mohanka and Manish Mohanka
Prospectus	The prospectus to be filed with the RoC for this Offer on or after the Pricing Date in accordance with the provisions of Section 26 of the Companies Act 2013 and the SEBI ICDR Regulations, containing the Offer Price, the size of the Offer and certain other information, including any addenda or corrigenda thereto
Public Offer Account Bank(s)	The bank(s) with which the Public Offer Account(s) shall be maintained, in this case being ICICI Bank Limited
Public Offer Account(s)	The account(s) to be opened with the Public Offer Account Bank(s) under Section 40(3) of the Companies Act 2013 to receive monies from the Anchor Escrow Accounts and the ASBA Accounts on the Designated Date
QIB Category	The portion of the Offer, being not more than 50% of the Offer or 6,834,738 Equity Shares to be Allotted to QIBs on a proportionate basis, including the Anchor Investor Portion (in which allocation shall be on a discretionary basis, as determined by our Company and the Selling

Term	Description
	Shareholders, in consultation with the BRLMs, subject to valid Bids being received at or above the Offer Price)
“Qualified Institutional Buyers”/ “QIBs”	A qualified institutional buyer as defined under Regulation 2(1)(ss) of the SEBI ICDR Regulations
“Red Herring Prospectus”/ “RHP”	This red herring prospectus dated November 23, 2021 issued in accordance with Section 32 of the Companies Act 2013 and the SEBI ICDR Regulations, which does not have complete particulars of the price at which the Equity Shares shall be Allotted and which shall be filed with the RoC at least three Working Days before the Bid/Offer Opening Date and will become the Prospectus after filing with the RoC after the Pricing Date, including any addenda or corrigenda thereto
Refund Account(s)	Account(s) opened with the Refund Bank from which refunds, if any, of the whole or part of the Bid Amount shall be made to Anchor Investors
Refund Bank(s)	The bank(s) with whom the Refund Account(s) will be opened, in this case being, ICICI Bank Limited
Registered Brokers	Stock brokers registered with the stock exchanges having nationwide terminals, other than the members of the Syndicate and eligible to procure Bids in terms of circular number CIR/CFD/14/2012 dated October 4, 2012 and the SEBI UPI Circulars, issued by SEBI
Registrar Agreement	The agreement dated August 17, 2021, entered into amongst our Company, the Selling Shareholders and the Registrar to the Offer in relation to the responsibilities and obligations of the Registrar to the Offer pertaining to the Offer
“Registrar and Share Transfer Agents”/ “RTAs”	Registrar and share transfer agents registered with SEBI and eligible to procure Bids at the Designated RTA Locations in terms of circular no. CIR/CFD/POLICYCELL/11/2015 dated November 10, 2015 and the SEBI UPI Circulars, issued by SEBI
Registrar to the Offer	Link Intime India Private Limited
Retail Category	The portion of the Offer, being not less than 35% of the Offer or 4,784,318 Equity Shares, available for allocation to Retail Individual Investors, which shall not be less than the minimum Bid lot, subject to availability in the Retail Category
“Retail Individual Investors”/ “RIIs”	Bidders (including HUFs and Eligible NRIs) whose Bid Amount for Equity Shares in the Offer is not more than ₹ 200,000 in any of the Bidding options in the Offer (including HUFs applying through their karta and Eligible NRIs and does not include NRIs other than Eligible NRIs)
Revision Form	The form used by the Bidders to modify the quantity of Equity Shares or the Bid Amount in any of their Bid cum Application Forms or any previous Revision Form(s), as applicable. QIBs and Non-Institutional Investors are not permitted to withdraw their Bid(s) or lower the size of their Bid(s) (in terms of quantity of Equity Shares or the Bid Amount) at any stage. Retail Individual Investors can revise their Bids during the Bid/Offer Period and withdraw their Bids until Bid/Offer Closing Date
SEBI UPI Circulars	The SEBI circular no. SEBI/HO/CFD/DIL2/CIR/P/2018/138 dated November 1, 2018, the SEBI circular no. SEBI/HO/CFD/DIL2/CIR/P/2019/50 dated April 3, 2019 and the SEBI circular no. SEBI/HO/CFD/DIL2/CIR/P/2019/76 dated June 28, 2019, SEBI circular no. SEBI/HO/CFD/DIL2/CIR/P/2019/85 dated July 26, 2019, SEBI circular no. SEBI/HO/CFD/DCR2/CIR/P/2019/133 dated November 8, 2019, the SEBI circular no. SEBI/HO/CFD/DIL2/CIR/P/2020/50 dated March 30, 2020, SEBI circular no. SEBI/HO/CFD/DIL2/P/CIR/2021/570 dated June 2, 2021, and any subsequent circulars or notifications issued by SEBI in this regard
“Self-Certified Banks”/ “SCSBs”	The banks registered with SEBI, which offer the facility of ASBA services, (i) in relation to ASBA, where the Bid Amount will be blocked by authorising an SCSB, a list of which is available on the website of SEBI at <a href="http://www.sebi.gov.in/sebiweb/other/OtherAction.do?doRecognisedFpi=yes&amp;intmId=34">www.sebi.gov.in/sebiweb/other/OtherAction.do?doRecognisedFpi=yes&amp;intmId=34</a> and updated from time to time and at such other websites as may be prescribed by SEBI from time to time, (ii) in relation to RIBs using the UPI Mechanism, a list of which is available on the website of SEBI at <a href="https://sebi.gov.in/sebiweb/other/OtherAction.do?doRecognisedFpi=yes&amp;intmId=40">https://sebi.gov.in/sebiweb/other/OtherAction.do?doRecognisedFpi=yes&amp;intmId=40</a> or such other website as updated from time to time Applications through UPI in the Offer could be made only through the SCSBs mobile applications (apps) whose name appears on the SEBI website. A list of SCSBs and mobile application, which, are live for applying in public issues using UPI Mechanism is appearing in the “list of mobile applications for using UPI in public issues” displayed on the SEBI website. The said list shall be updated on the SEBI website
Selling Shareholders	Investor Selling Shareholder and Promoter Selling Shareholders, collectively
Share Escrow Agreement	The agreement dated November 17, 2021 entered into amongst the Selling Shareholders, our Company and a share escrow agent, in connection with the transfer of the respective portion of Offered Shares and credit of such Equity Shares to the demat account of the Allottees
Specified Locations	Bidding centres where the Syndicate shall accept Bid cum Application Forms from the Bidders, a list of which is which is available on the website of SEBI ( <a href="http://www.sebi.gov.in">www.sebi.gov.in</a> ) and updated from time to time

<b>Term</b>	<b>Description</b>
Sponsor Bank	The Banker to the Offer registered with SEBI which is appointed by our Company to act as a conduit between the Stock Exchanges and NPCI in order to make the mandate collect requests and / or payment instructions of the RIIs into the UPI and carry out any other responsibilities, in terms of the SEBI circular bearing number SEBI/HO/CFD/DIL2/CIR/P/2018/138) dated November 1, 2018, in this case being, ICICI Bank Limited
Stock Exchanges	Collectively, BSE Limited and National Stock Exchange of India Limited
Syndicate Agreement	The agreement dated November 23, 2021 entered into amongst the members of the Syndicate, our Company, the Selling Shareholders and the Registrar to the Offer in relation to the collection of Bid cum Application Forms by the Syndicate
Syndicate Members	Intermediaries (other than the BRLMs) registered with SEBI and permitted to carry out activities as an underwriter, in this case being, JM Financial Services Limited
“Syndicate”/ “members of the Syndicate”	Collectively, the BRLMs and the Syndicate Members
Underwriters	[•]
Underwriting Agreement	The agreement dated [•] entered into amongst our Company, the Selling Shareholders and the Underwriters, to be entered into on or after the Pricing Date
UPI	Unified payments interface which is an instant payment mechanism, developed by NPCI
UPI ID	Identity document created on UPI for single-window mobile payment system developed by the NPCI
UPI Mandate Request	A request (intimating the RII by way of a notification on the UPI application and by way of a SMS directing the RII to such UPI application) to the RII initiated by the Sponsor Bank to authorize blocking of funds in the relevant ASBA Account through the UPI application equivalent to Bid Amount and subsequent debit of funds in case of Allotment
UPI Mechanism	The Bidding mechanism that may be used by an RII to make a Bid in the Offer in accordance with the SEBI UPI Circulars
UPI PIN	Password to authenticate UPI transaction
Working Day(s)	All days on which commercial banks in Mumbai are open for business; provided however, with reference to (a) announcement of Price Band; and (b) Bid/Offer Period, the term Working Day shall mean all days, excluding Saturdays, Sundays and public holidays, on which commercial banks in Mumbai are open for business; and (c) the time period between the Bid/Offer Closing Date and the listing of the Equity Shares on the Stock Exchanges, “Working Day” shall mean all trading days of the Stock Exchanges, excluding Sundays and bank holidays, as per circulars issued by SEBI, including the SEBI UPI Circulars

### Conventional and General Terms and Abbreviations

<b>Term</b>	<b>Description</b>
AIF(s)	Alternative Investment Fund(s) as defined in and registered with SEBI under the SEBI AIF Regulations
Air Act	Air (Prevention and Control of Pollution) Act, 1981
API	Application performing interface
BSE	BSE Limited
CBDT	Central Board of Direct Taxes
CDSL	Central Depository Services (India) Limited
Central Government	Government of India
CIN	Corporate Identity Number
Companies Act	Companies Act, 1956 and the Companies Act, 2013, read with the rules, regulations, clarifications and modifications thereunder
Companies Act, 1956	The erstwhile Companies Act, 1956 read with the rules, regulations, clarifications and modifications thereunder
“Companies Act, 2013”/ “Companies Act”	Companies Act, 2013 read with the rules, regulations, clarifications and modifications thereunder
Consolidated FDI Policy	The consolidated FDI Policy, effective from October 15, 2020, issued by the DPIIT, and any modifications thereto or substitutions thereof, issued from time to time
COVID-19	A public health emergency of international concern as declared by the World Health Organization on January 30, 2020 and a pandemic on March 11, 2020
CSR	Corporate social responsibility
Depositories Act	Depositories Act, 1996
Depository	A depository registered with the SEBI under the Securities and Exchange Board of India (Depositories and Participants) Regulations, 1996
DP ID	Depository Participant’s identity number
DPIIT	Department of Promotion of Industry and Internal Trade, Ministry of Commerce and Industry, Government of India
EGM	Extraordinary general meeting

Term	Description
EP Act	Environment Protection Act, 1986
EPF Act	Employees' Provident Fund and Miscellaneous Provisions Act, 1952
EPS	Earnings per share
ESI Act	Employees' State Insurance Act, 1948
Factories Act	The Factories Act, 1948
FCNR Account	Foreign Currency Non Resident (Bank) account established in accordance with the FEMA
FDI	Foreign direct investment
FEMA	Foreign Exchange Management Act, 1999 read with rules and regulations thereunder
FEMA Rules	Foreign Exchange Management (Non-debt Instruments) Rules, 2019 issued by the Ministry of Finance, Government of India
"Financial Year"/ "Fiscal"/ "Fiscal Year"/ "FY"	The period of 12 months commencing on April 1 of the immediately preceding calendar year and ending on March 31 of that particular calendar year
FPIs	A foreign portfolio investor as defined under the SEBI FPI Regulations
FVCI	Foreign Venture Capital Investors (as defined under the Securities and Exchange Board of India (Foreign Venture Capital Investors) Regulations, 2000) registered with SEBI
GDP	Gross Domestic Product
Gross Block	Property, plant and equipment, intangibles and capital work-in-progress
GST	Goods and services tax
HUF(s)	Hindu Undivided Family(ies)
ICAI	Institute of Chartered Accountants of India
IDC(s)	Industrial Development Corporation(s)
IFRS	International Financial Reporting Standards
Income Tax Act	Income-tax Act, 1961
Ind AS	Indian Accounting Standards notified under Section 133 of the Companies Act, 2013 read with the Companies (Indian Accounting Standards) Rules, 2015, as amended
"INR"/"Indian Rupee"/"₹"/"Rs."	Indian Rupee, the official currency of the Republic of India
IT	Information Technology
IT Act	Information Technology Act, 2002
Legal Metrology Act	Legal Metrology Act, 2009
MCA	Ministry of Corporate Affairs, Government of India
Mn	Million
Mutual Funds	Mutual funds registered with the SEBI under the Securities and Exchange Board of India (Mutual Funds) Regulations, 1996
NACH	National Automated Clearing House
NBFC	Non-banking financial company
NEFT	National Electronic Funds Transfer
NPCI	National Payments Corporation of India
"NR"/"Non-resident"	A person resident outside India, as defined under the FEMA and includes an NRI
NRI	Non-Resident Indian
NSDL	National Securities Depository Limited
NSE	National Stock Exchange of India Limited
P/E Ratio	Price/Earnings Ratio
PAN	Permanent account number
PAT	Profit after tax
Patents Act	The Patents Act, 1970
RBI	Reserve Bank of India
Regulation S	Regulation S under the U.S. Securities Act
ROCE	Return on Capital Employed
ROE	Return on Equity
RoNW	Return on Net Worth
SBO Rules	Companies (Significant Beneficial Owners) Rules, 2018, as amended
SCRA	Securities Contract (Regulation) Act, 1956, as amended
SCRR	Securities Contracts (Regulation) Rules, 1957, as amended
SEBI	Securities and Exchange Board of India constituted under the SEBI Act
SEBI Act	Securities and Exchange Board of India Act, 1992, as amended
SEBI AIF Regulations	Securities and Exchange Board of India (Alternative Investment Funds) Regulations, 2012, as amended
SEBI FPI Regulations	Securities and Exchange Board of India (Foreign Portfolio Investors) Regulations, 2019, as amended
SEBI FVCI Regulations	Securities and Exchange Board of India (Foreign Venture Capital Investors) Regulations, 2000, as amended



Term	Description
SEBI ICDR Regulations	Securities and Exchange Board of India (Issue of Capital and Disclosure Requirements) Regulations, 2018, as amended
SEBI Listing Regulations	SEBI (Listing Obligations and Disclosure Requirements) Regulations, 2015, as amended
SEBI SBEB SE Regulations	SEBI (Share Based Employee Benefits and Sweat Equity) Regulations, 2021
SEBI VCF Regulations	Securities and Exchange Board of India (Venture Capital Fund) Regulations, 1996, as amended
SGD	Singapore dollar, the official currency of the country of Singapore
STT	Securities Transaction Tax
Takeover Regulations	Securities and Exchange Board of India (Substantial Acquisition of Shares and Takeovers) Regulations, 2011
Trademarks Act	The Trademarks Act, 1999
U.S. GAAP	Generally Accepted Accounting Principles in the United States of America
U.S. Securities Act	United States Securities Act of 1933, as amended
“US\$”/ “USD”/ “US Dollar”	United States Dollar, the official currency of the United States of America
“USA”/ “U.S.”/ “US”/ “United States”	United States of America, its territories and possessions, any state of the United States of America and the District of Columbia
UK	The United Kingdom
VAT	Value Added Tax
VCFs	Venture capital funds as defined in and registered with the SEBI under the SEBI VCF Regulations
Water Act	Water (Prevention and Control of Pollution) Act, 1974

### Industry Related Terms/Abbreviations

Term	Description
AG	Autogenous Mill
APAC	Asia-Pacific
Average	Sum of the value being considered for each of the relevant Fiscals divided by the number of Fiscals being considered
B	Billion
Beneficiation	Process of improvement of the economic value of ore by removing waste and by-products to achieve a higher grade ore concentrate
CAGR	Compound annual growth rate is a business and investing specific term for the geometric progression ratio that provides a constant rate of return over the time period calculated as $(\text{end value} / \text{start value})^{(1 / \text{years})} - 1$
CapEx	Capital Expenditure
Conveyor products	Components used with conveyor belts
DynaPrime	Composite liner of rubber and steel
EBIT	Earnings before Interest and Taxes
EBITDA	Restated profit before share of restated net profit of joint venture accounted for using equity method and tax, finance costs, depreciation and amortisation expenses
EBITDA Margin	EBITDA divided by Total Income
EMER	Europe Middle East and Russia
ERP	Enterprise Resource Planning
EV	Electric Vehicle
HCL	Hindustan Copper Limited
Hydrocyclones	Machine that generates centrifugal force using fluid pressure and a flux pattern that can separate particulate matter and droplets from a fluid medium
ICSG	International Copper Study Group
IEA	International Energy Agency
Kg	Kilograms
LATAM	Latin America
LME	London Metal Exchange
MEI Scheme	Merchandise Exports from India Scheme
Mill	Machine that grinds, cuts, and crushes solid materials into useable sizes for further processing
Mill Liners	Metallic, rubber or composite materials used to protect Mills from the wear that comes with grinding harsh raw materials
Net worth	Net worth means the aggregate value of the equity share capital, preference share capital and other equity, as per restated consolidated financial information
Oz	Ounce
Rapido	Screening machine used for separation of particles according to size
ROE	Calculated as restated total profit for the year divided by closing total equity

Term	Description
ROCE	Restated profit before share of restated net profit of joint venture accounted for using the equity method, tax and finance costs divided by sum of net worth and borrowings
SAG	Semi-autogenous mill
Tribology	Science and engineering of interacting surfaces in relative motion
Trommel	Mechanical screening machine that separates materials and finds application in mining, fertilizer, compost and aggregates
USGS	United States Geological Survey
YoY	Year-over-Year

## **CERTAIN CONVENTIONS, USE OF FINANCIAL INFORMATION AND MARKET DATA AND CURRENCY OF PRESENTATION**

### **Certain Conventions**

All references in this Red Herring Prospectus to “India” are to the Republic of India, together with its territories and possessions. All references to the “USA”, “US”, the “U.S.” or the “United States” are to the United States of America, together with its territories and possessions. All references in this Red Herring Prospectus to “Australia”, “Canada”, “Chile”, “Singapore” and “South Africa” are to the Commonwealth of Australia, Dominion of Canada, Republic of Chile, Republic of Singapore and Republic of South Africa together with their territories and possessions, respectively.

Unless stated otherwise, all references to page numbers in this Red Herring Prospectus are to the page numbers of this Red Herring Prospectus.

### **Financial Data**

Unless indicated otherwise, the financial information in this Red Herring Prospectus is derived from our Restated Consolidated Financial Information. Certain additional financial information pertaining to our Group Companies are derived from their respective financial statements. The Restated Consolidated Financial Information included in this Red Herring Prospectus comprises of the Restated Consolidated Statement of Assets and Liabilities as at June 30, 2021, March 31, 2021, March 31, 2020 and March 31, 2019, the Restated Consolidated Statement of Profit and Loss, the Restated Consolidated Statement of Changes in Equity, Restated Consolidated Statement of Cash Flows for the three months period ended June 30, 2021 and years ended March 31, 2021, March 31, 2020 and March 31, 2019, notes to the Restated Consolidated Financial Information and Statement of Adjustments to the Audited Special Purpose Interim Consolidated Financial Statements as at and for the three months period ended June 30, 2021 and Audited Consolidated Financial Statements as at and for the years ended March 31, 2021, March 31, 2020 and March 31, 2019. The Restated Consolidated Financial Information have been prepared in accordance with the requirements of the relevant provisions of the Companies Act, 2013, the SEBI ICDR Regulations and the Guidance Note on Reports in Company Prospectuses (Revised 2019) issued by the ICAI. For further information, see, “*Summary Financial Information*” and “*Restated Consolidated Financial Information*” on pages 66 and 207, respectively.

The audited special purpose interim consolidated financial statements for the three months period ended June 30, 2021 and the audited consolidated financial statements for the years ended March 31, 2021, March 31, 2020 and March 31, 2019 have been audited by Price Waterhouse & Co Bangalore LLP, our Statutory Auditors.

Our Company’s financial year commences on April 1 of the immediately preceding calendar year and ends on March 31 of that particular calendar year, so all references to a particular financial year are to the 12 month period commencing on April 1 of the immediately preceding calendar year and ending on March 31 of that particular calendar year.

Our Restated Consolidated Financial Information have been prepared in accordance with Ind AS. There are significant differences between International Financial Reporting Standards (“**IFRS**”) and Generally Accepted Accounting Principles in the United States of America (“**U.S. GAAP**”). The degree to which the financial information included in this Red Herring Prospectus will provide meaningful information is entirely dependent on the reader’s level of familiarity with Indian accounting policies and practices, Ind AS, the Companies Act 2013, the SEBI ICDR Regulations and the Guidance Note on Reports in Company Prospectuses (Revised 2019) issued by the Institute of Chartered Accountants of India. Accordingly, any reliance by persons not familiar with Ind AS, the Companies Act 2013, the SEBI ICDR Regulations, the Guidance Note on Reports in Company Prospectuses (Revised 2019) issued by the Institute of Chartered Accountants of India and practices on the financial disclosures presented in this Red Herring Prospectus should accordingly be limited. We have not attempted to quantify the impact of IFRS or U.S. GAAP on the financial information included in this Red Herring Prospectus, nor do we provide a reconciliation of our financial information to those under U.S. GAAP or IFRS and we urge you to consult your own advisors regarding such differences and their impact on our financial information. For details in connection with risks involving differences between Ind AS, U.S. GAAP and IFRS see “*Risk Factors – Significant differences exist between Ind AS and other accounting principles, such as U.S. GAAP and IFRS, which investors may be more familiar with and may consider material to their assessment of our financial condition.*” on page 62.

Certain figures contained in this Red Herring Prospectus, including financial information, have been subject to rounding adjustments. All decimals, including percentages, have been rounded off to two decimal points. In certain instances, (i) the sum or percentage change of such numbers may not conform exactly to the total figure given; and (ii) the sum of the numbers in a column or row in certain tables may not conform exactly to the total figure given for that column or row. However, where any figures that may have been sourced from third-party industry sources are rounded off to other than two decimal points in their respective sources, such figures appear in this Red Herring Prospectus as rounded off to such number of decimal points as provided in their respective sources.

Unless the context otherwise indicates, any percentage or amounts, as set forth in “*Risk Factors*”, “*Business*”, “*Management’s Discussion and Analysis of Financial Condition and Results of Operations*” on page 23, 141, and 317, respectively, and elsewhere in this Red Herring Prospectus have been calculated on the basis of the Restated Consolidated Financial Information of our Company.

### **Non-GAAP Financial Measures**

Certain non-GAAP financial measures relating to our financial performance have been included in this Red Herring Prospectus. We compute and disclose such non-GAAP financial measures relating to our financial performance as we consider such information to be supplemental and useful measures of our business and financial performance. These non-GAAP financial measures and other information relating to financial performance may not be computed on the basis of any standard methodology that is applicable across the industry and therefore, may not be comparable to financial measures of similar nomenclature that may be computed and presented by other companies and are not measures of operating performance or liquidity defined by generally accepted accounting principles, including Ind AS and may not be comparable to similarly titled measures presented by other companies.

### **Industry and Market Data**

We have paid and commissioned a report titled “*Global Market Assessment – Select Mineral Processing Equipment*” dated October 12, 2021 (“**F&S Report**”), prepared by Frost & Sullivan, also available at the following weblink, <https://www.tegaindustries.com/tega-investors/#indreport>, for the purpose of confirming our understanding of the industry in connection with the Offer. Unless otherwise indicated, industry and market data used throughout this Red Herring Prospectus, including in “*Our Business*” and “*Industry Overview*” on pages 141 and 108 has been obtained or derived from the F&S Report. Further, in this regard, Frost & Sullivan has issued the following disclaimer:

*“Global Market Assessment – Select Mineral Processing Equipment” (the “Report”) has been prepared for the proposed initial public offering of equity shares (the “Offer”) by Tega Industries Limited (the “Company”).*

*This study has been undertaken through extensive primary and secondary research, which involves discussing the status of the industry with leading market participants and experts, and compiling inputs from publicly available sources, including official publications and research reports. Estimates provided by Frost & Sullivan (India) Private Limited (“Frost & Sullivan”) and its assumptions are based on varying levels of quantitative and qualitative analyses, including industry journals, company reports and information in the public domain.*

*Frost & Sullivan has prepared this study in an independent and objective manner, and it has taken all reasonable care to ensure its accuracy and completeness. We believe that this study presents a true and fair view of the industry within the limitations of, among others, secondary statistics and primary research, and it does not purport to be exhaustive. The results that can be or are derived from these findings are based on certain assumptions and parameters/conditions. As such, a blanket, generic use of the derived results or the methodology is not encouraged.*

*Forecasts, estimates, predictions, and other forward-looking statements contained in this report are inherently uncertain because of changes in factors underlying their assumptions, or events or combinations of events that cannot be reasonably foreseen. Actual results and future events could differ materially from such forecasts, estimates, predictions, or such statements.*

*In making any decision regarding the transaction, the recipient should conduct its own investigation and analysis of all facts and information contained in the prospectus of which this report is a part and the recipient must rely on its own examination and the terms of the transaction, as and when discussed. The recipients should not construe any of the contents in this report as advice relating to business, financial, legal, taxation or investment matters*

and are advised to consult their own business, financial, legal, taxation, and other advisors concerning the transaction.”

Industry publications generally state that the information contained in such publications has been obtained from sources generally considered reliable, but their accuracy, adequacy or completeness and underlying assumptions are not guaranteed and their reliability cannot be assured. Accordingly, no investment decisions should be made based on such information. The data used in these sources may have been reclassified by us for the purposes of presentation. Data from these sources may also not be comparable. The extent to which the industry and market data presented in this Red Herring Prospectus is meaningful depends upon the reader’s familiarity with and understanding of the methodologies used in compiling such data. There are no standard data gathering methodologies in the industry in which we conduct our business and methodologies and assumptions may vary widely among different market and industry sources.

Such data involves risks, uncertainties and numerous assumptions and is subject to change based on various factors, including those discussed in “**Risk Factors**” on page 23.

### Currency and Units of Presentation

All references to:

- “**Indian Rupees**” or “**₹**” or “**Rs.**” are to Indian Rupees, the official currency of the Republic of India;
- “**AUD**” are to Australian Dollars, the official currency of Australia;
- “**CAD**” are to Canadian Dollar, the official currency of Canada;
- “**CLP**” are to Chilean peso, the official currency of Chile;
- “**Euro**” or “**€**” are to Euro, the official currency of the European Union;
- “**GBP**” are to British pound sterling, the official currency of the United Kingdom
- “**GHS**” are to Ghanaian cedi, the official currency of the Republic of Ghana
- “**SGD**” are to Singapore dollar, the official currency of the Republic of Singapore;
- “**US\$**”, “**U.S. Dollar**”, “**USD**” or “**U.S. Dollars**” are to United States Dollars, the official currency of the United States of America; and
- “**ZAR**” are to South African Rand, the official currency of the Republic of South Africa.

In this Red Herring Prospectus, our Company has presented certain numerical information. All figures have been expressed in millions. One million represents “10 lakhs” or 1,000,000. However, where any figures that may have been sourced from third-party industry sources are expressed in denominations other than millions in their respective sources, such figures appear in this Red Herring Prospectus expressed in such denominations as provided in such respective sources.

### Exchange Rates

This Red Herring Prospectus contains conversions of U.S. Dollars and other currency amounts into Indian Rupees that have been presented solely to comply with the requirements of the SEBI ICDR Regulations. These conversions should not be construed as a representation that such currency amounts could have been, or can be converted into Indian Rupees, at any particular rate, or at all.

The exchange rates of certain currencies used in this Red Herring Prospectus into Indian Rupees are provided below.

<i>(in ₹)</i>				
Currency	Exchange rate as on June 30, 2021	Exchange rate as on March 31, 2021	Exchange rate as on March 31, 2020	Exchange rate as on March 31, 2019
1 USD	74.33	73.11	75.67	69.16
1 AUD	55.77	55.70	46.08	49.02

Currency	Exchange rate as on June 30, 2021	Exchange rate as on March 31, 2021	Exchange rate as on March 31, 2020	Exchange rate as on March 31, 2019
1 CAD	59.94	58.03	53.08	51.54
1EUR	88.40	85.75	82.77	77.67
1 GHS	12.63	12.62	13.05	12.84
1 GBP	103.01	100.75	93.50	90.53
1 SGD	55.32	54.35	53.03	51.04
1 CLP	0.10	0.10	0.09	0.10
1 ZAR	5.20	4.94	4.23	4.77

Source: Rates of all the currencies are taken from FEDAI (Federation of Delers 'Association of India) rate ([www.fedai.org.in](http://www.fedai.org.in)) except for GHS & CLP which is taken from Oanda ([www1.oanda.com](http://www1.oanda.com))

Note: In case June 30, 2021 or March 31 of any of the respective years/ period is a public holiday, the previous working day not being a public holiday has been considered.

## FORWARD-LOOKING STATEMENTS

This Red Herring Prospectus contains certain “forward-looking statements”. These forward-looking statements include statements which can generally be identified by words or phrases such as “*aim*”, “*anticipate*”, “*believe*”, “*expect*”, “*estimate*”, “*intend*”, “*likely to*”, “*objective*”, “*plan*”, “*propose*”, “*will continue*”, “*seek to*”, “*will pursue*” or other words or phrases of similar import. Statements that describe our strategies are also forward-looking statements.

All forward-looking statements are based on our current plans, estimates and expectations and actual results may differ materially from those suggested by such forward-looking statements. All forward-looking statements are subject to risks, uncertainties and assumptions about us that could cause actual results to differ materially from those contemplated by the relevant forward-looking statement. This may be due to risks or uncertainties associated with our expectations with respect to, but not limited to, regulatory changes pertaining to the industries in India in which we have our businesses and our ability to respond to them, our ability to successfully implement our strategy, our growth and expansion, technological changes, our exposure to market risks, general economic and political conditions in India, which have an impact on our business activities or investments, the monetary and fiscal policies of India, inflation, deflation, unanticipated turbulence in interest rates, foreign exchange rates, equity prices or other rates or prices, the performance of the financial markets in India and globally, changes in domestic laws, regulations and taxes, changes in competition in our industry and incidence of any natural calamities and/or acts of violence. Important factors that would cause actual results to differ materially include, but not limited to:

- Our global manufacturing facilities, sales and operations expose us to the risks of doing business in foreign countries, which may adversely affect our business, financial condition and results of operations.
- Any failure to expand or effectively manage our sales and distribution network, both in India and overseas, could have an adverse effect on our business, financial condition and results of operations.
- We are dependent on third party logistic and support service providers for the delivery of raw materials and finished products and any disruptions in their services including transportation services or a decrease in the quality of their services may adversely affect our business, financial condition and results of operations.
- Any shortfall or delay in the supply of our raw materials or an increase in our raw material costs, may adversely affect the pricing and supply of our products and have an adverse effect on our business, results of operations and financial condition.
- We are dependent on a few key suppliers of certain raw materials and do not have long term contracts or exclusive arrangements with these key suppliers. Accordingly, the loss of, or a significant reduction in supply by, such suppliers could adversely affect our business, financial condition and results of operations.
- We are subject to risks associated with expansion into new geographic markets globally. Any inability to expand into new geographic markets may adversely affect our growth and future prospects.
- Depreciation of the Indian Rupee and exchange rate fluctuations in currencies in which we do business or have outstanding borrowings may materially and adversely impact our business, financial condition and results of operations.
- We export our products to various countries, on account of which we may be subject to significant import duties or restrictions. Further, unavailability of fiscal benefits enjoyed by us or our inability to comply with related requirements may have an adverse effect on our business and results of operations.
- Our Company, our Promoters and our Directors are involved in certain legal proceedings, and an adverse outcome in any such proceedings may adversely affect our business, financial condition and growth strategy.
- There are outstanding actions by statutory or regulatory authorities against our Company and Promoters. Any adverse outcome in such proceedings may have an adverse impact on our business, financial condition, results of operations and cash flows.

For a further discussion of factors that could cause our actual results to differ, see “*Risk Factors*”, “*Our Business*” and “*Management’s Discussion and Analysis of Financial Condition and Results of Operations*” on pages 23, 141 and 317, respectively. By their nature, certain market risk disclosures are only estimates and could be materially different from what actually occurs in the future. As a result, actual future gains or losses could be materially different from those that have been estimated. Forward-looking statements reflect our current views as of the date of this Red Herring Prospectus and are not a guarantee of future performance. Although we consider that the assumptions on which such statements are based to be reasonable, any such assumptions as well as the statement based on them could prove to be inaccurate.

Neither our Company, nor the Directors, nor the Selling Shareholders nor the Syndicate, nor any of their respective affiliates have any obligation to update or otherwise revise any statements reflecting circumstances arising after the date hereof or to reflect the occurrence of underlying events, even if the underlying assumptions do not come to fruition. In accordance with SEBI requirements, our Company and the BRLMs will ensure that investors in India are informed of material developments until the receipt of final listing and trading approvals for the Equity Shares pursuant to the Offer.

In accordance with SEBI ICDR Regulations, the Selling Shareholders severally and not jointly will ensure that Bidders in India are informed of material developments in relation to statements and undertakings specifically made by the respective Selling Shareholders in relation to themselves and their respective portion of the Offered Shares in this Red Herring Prospectus until the time of the grant of listing and trading permission by the Stock Exchanges. Only statements and undertakings which are specifically “confirmed” or “undertaken” by the Selling Shareholders, as the case may be, in this Red Herring Prospectus shall, severally and not jointly, be deemed to be statements and undertakings made by such Selling Shareholders.



## SUMMARY OF THE OFFER DOCUMENT

The following is a general summary of the terms of the Offer and is not exhaustive, nor does it purport to contain a summary of all the disclosures in this Red Herring Prospectus or all details relevant to prospective investors. This summary should be read in conjunction with, and is qualified in its entirety by, the more detailed information appearing elsewhere in this Red Herring Prospectus, including in the sections entitled “Risk Factors”, “The Offer”, “Capital Structure”, “Objects of the Offer”, “Industry Overview”, “Business”, “Outstanding Litigation and Material Developments”, “Offer Procedure” and “Main Provisions of Articles of Association” on pages 23, 64, 79, 98, 108, 141, 355, 380 and 398 respectively.

### Summary of Business

We are a leading manufacturer and distributor of specialized ‘critical to operate’ and recurring consumable products for the global mineral beneficiation, mining and bulk solids handling industry, on the basis of sales as of June 30, 2021 (Source: F&S Report). Globally, we are the second largest producers of polymer-based mill liners, on the basis of revenues as of June 30, 2021 (Source: F&S Report). We offer comprehensive solutions to marquee global clients in the mineral beneficiation, mining and bulk solids handling industry, through our wide product portfolio. For further details, see “Business” beginning on page 141.

### Summary of Industry

In 2020, Asia-Pacific accounted for 71% of the global mining industry, followed by North America with 9%. Global commodity mineral production during 2020 was 10.2 billion tons. The GDP contribution of the mining and quarrying sector, both in terms of nominal and real GDP, has declined over the last decade. Global crushing, screening, and mineral processing equipment market size was estimated at \$20 billion in 2020. Global growth is expected to accelerate to 5.6% in 2021 and be partially supported by the low GDP base effect from 2020. For further details, see “Industry Overview” beginning on page 108.

### Promoters

Our Promoters are Madan Mohan Mohanka, Manju Mohanka, Mehul Mohanka, Manish Mohanka and NFSPL.

### Offer Size

Offer of up to 13,669,478 Equity Shares for cash at a price of ₹[•] per Equity Share aggregating up to ₹[•] million by the Selling Shareholders. The Offer would constitute [•]% of the post-Offer paid-up Equity Share capital of our Company. For further details, see “The Offer” beginning on page 64.

### Objects of the Offer

The objects of the Offer are to (i) carry out the Offer for Sale of up to 13,669,478 Equity Shares by the Selling Shareholders; and (ii) achieve the benefits of listing the Equity Shares on the Stock Exchanges. Our Company will not receive any proceeds from the Offer and all such proceeds will go to the Selling Shareholders.

### Aggregate pre-Offer Shareholding of Promoters, Promoter Group and Selling Shareholders

The aggregate pre-Offer shareholding of Promoters, Promoter Group and Selling Shareholders as on the date of this Red Herring Prospectus is as follows:

Category of Shareholders	No. of Equity Shares held	% of total paid up pre-Offer Equity Share capital
<b>Promoters</b>		
Madan Mohan Mohanka	8,663,159	13.07
Manish Mohanka	7,941,856	11.98
Mehul Mohanka	2,003,315	3.02
Nihal Fiscal Services Private Limited	36,553,153	55.14
<b>Total</b>	<b>55,161,483</b>	<b>83.21</b>
<b>Promoter Group</b>		
Marudhar	1,300,000	1.96
<b>Total</b>	<b>1,300,000</b>	<b>1.96</b>
<b>Selling Shareholders</b>		
<i>Promoter Selling Shareholder(s)</i>		

Category of Shareholders	No. of Equity Shares held	% of total paid up pre- Offer Equity Share capital
Madan Mohan Mohanka	8,663,159	13.07
Manish Mohanka	7,941,856	11.98
<i>Investor Selling Shareholder</i>		
Wagner Limited**	9,691,890	14.62
<b>Total</b>	<b>26,296,905</b>	<b>39.67</b>

\*\*Pursuant to resolutions dated November 10, 2021 passed by our Board and Shareholders, 8,692,281 CCPP held by Wagner Limited were converted to 8,692,281 Equity Shares, For details, see “Capital Structure- Notes to the Capital Structure – Equity Share capital history of our Company” and “Capital Structure - Notes to the Capital Structure – Preference Share capital history of our Company” on pages 79 and 82.

## Summary of Restated Consolidated Financial Information

A summary of the financial information of our Company as per the Restated Consolidated Financial Information is as follows:

Particulars	Three months period ended June 30, 2021	Fiscal		
		2021	2020	2019
Equity share capital	576.01	576.01	576.01	576.01
Preference share capital	86.92	86.92	86.92	86.92
Net worth <sup>^</sup>	6,311.52	6,137.22	4,624.89	4,011.05
Total income	1,793.86	8,566.84	6,955.42	6,430.13
Restated total profit for the period/ year	118.82	1,364.05	655.04	326.70
Earnings per share (basic and diluted)*				
- Basic (in ₹)	2.10	24.10	11.57	5.76
- Diluted (in ₹)	1.78	20.48	9.84	4.90
Net asset value per share (in ₹) <sup>^^</sup>	108.06	105.04	78.78	68.13
Borrowings <sup>^^^</sup>	1,842.38	1,878.02	2,439.34	2,126.90

<sup>^</sup> Net worth means the aggregate value of the equity share capital, preference share capital and other equity, as per restated consolidated financial information.

<sup>^^</sup> Net Asset Value per equity share represents net worth attributable to Equity Shareholder (Equity Share capital together with other equity as per restated consolidated financial statement) as at the end of the fiscal year divided by the number of Equity Shares outstanding at the end of the year

<sup>^^^</sup> Borrowings are inclusive of current maturities of other borrowings amounting to ₹228.36 million for three months period ended June 30, 2021, ₹ 215.20 million for FY 2021, ₹ 117.90 million for FY 2020, and ₹ 244.57 million for FY 2019.

\*Basic EPS and Diluted EPS for the three months period ended June 30, 2021 are not annualised.

## Qualifications of the Statutory Auditors

There are no qualifications in the audit reports that require adjustments in the Restated Consolidated Financial Information.

## Summary of Outstanding Litigation

A summary of outstanding litigation proceedings involving our Company, our Promoters, our Directors, our Subsidiaries and litigation involving our Group Companies which have a material impact on the Company, as on the date of this Red Herring Prospectus is as follows:

Type of Litigation	Number of cases	Amount* (in ₹ million)
<b>Litigation involving our Company</b>		
Criminal litigation	3 <sup>^</sup>	2.70
Material civil litigation	3	35.43
Actions by statutory or regulatory authorities	2	-
Direct and indirect tax proceedings	24	263.78
<b>Total</b>	<b>32</b>	<b>301.91</b>
<b>Litigation involving our Promoters</b>		
Actions by statutory or regulatory authorities	1	-
Direct and indirect tax proceedings	21	22.22
<b>Total</b>	<b>22</b>	<b>22.22</b>
<b>Litigation involving our Directors</b>		
Actions by statutory or regulatory authorities	1	-
Direct and indirect tax proceedings	9	2.71

Type of Litigation	Number of cases	Amount* (in ₹ million)
<b>Total</b>	<b>10</b>	<b>2.71</b>
<b>Litigation involving our Subsidiaries</b>		
Actions by statutory or regulatory authorities	5	-
<b>Total</b>	<b>5</b>	<b>-</b>
<b>Litigation involving our Group Companies**</b>		
Nil	Nil	Nil

\*to the extent quantifiable

\*\*This comprises the pending proceedings which may have a material impact on our Company, in accordance with the Materiality Policy.

^ These three criminal complaints have been filed by the Company against Tecpro Systems Ltd. under the Negotiable Instruments Act, 1881. For details, see “*Outstanding Litigation and Material Developments- Litigation involving our Company*” on page 355.

For further details of the outstanding litigation proceedings, see “*Outstanding Litigation and Other Material Developments*” beginning on page 355.

## Risk Factors

Please see “*Risk Factors*” beginning on page 23.

## Summary of Contingent Liabilities of our Company

A summary of our contingent liabilities as on June 30, 2021 as indicated in our Restated Consolidated Financial Information is as follows:

Particulars	(in ₹ million)
	As of June 30, 2021
Disputed Excise duty	14.75
Disputed Service Tax	3.08
Disputed Income Tax	64.54
Disputed sales tax	6.56
Pending finalisation of legal / arbitration proceedings	4.05
The Company stands as surety in connection with General Bond executed by MM Aqua Technologies Limited	1.50

For details, see “*Restated Consolidated Financial Information – Annexure V - Note 44A - Contingent Liabilities and Capital Commitments*” on page 285.

## Summary of Related Party Transactions

A summary of related party transactions, as per the requirements under Ind AS 24, are as follows:

Transactions during the period / year ended	Three months period ended June 30, 2021	Fiscal		
		2021	2020	2019
<b>Sale of goods</b>				
Hosch Equipment (India) Limited	2.93	12.56	9.04	5.93
MM Aqua Technologies Limited	0.04	-	3.01	0.49
<b>Purchase of goods</b>				
Hosch Equipment (India) Limited	-	0.96	0.83	0.17
Maple Orgtech (India) Limited	-	0.10	-	0.04
<b>Re-imburement of expenses</b>				
Hosch Equipment (India) Limited	0.11	0.10	0.19	0.02
TPW Engineering Limited	-	0.05	-	-
Maple Orgtech (India) Limited	0.08	0.04	-	-
<b>Recovery of expenses</b>				
Hosch Equipment (India) Limited	-	0.21	0.08	0.01
MM Aqua Technologies Limited	-	0.02	-	0.21
<b>Sales commission earned</b>				
Hosch Equipment (India) Limited	3.11	15.29	12.79	13.18
<b>Rent/Service charges/Hire charges</b>				
TPW Engineering Limited	6.77	25.80	24.17	22.89
Maple Orgtech (India) Limited	0.09	0.38	0.39	0.42

Transactions during the period / year ended	Three months period ended June 30, 2021	Fiscal		
		2021	2020	2019
Manish Mohanka	0.39	1.50	1.43	1.36
Manju Mohanka	0.04	0.13	0.13	0.12
<b>Dividend received</b>				
Hosch Equipment (India) Limited	-	2.25	6.75	2.25
<b>Contribution to post employment benefit plan</b>				
Tega India Ltd. Employees Gratuity Fund	-	0.00 <sup>^</sup>	30.00	11.00
Tega Industries (SEZ) Ltd. Gratuity Trust	-	0.03	0.00 <sup>^</sup>	0.00 <sup>^</sup>
Tega India & Associate Companies Super Annuation Fund	1.73	6.36	6.55	6.50
Tega Industries (SEZ) Ltd. Super Annuation Fund	0.16	0.59	0.50	0.39
<b>Business support service expense</b>				
MM Aqua Technologies Limited	0.47	1.86	-	-
<b>Business support service income</b>				
Hosch Equipment (India) Limited	2.29	9.30	9.39	9.34
Maple Orgtech (India) Limited	0.08	0.30	0.34	0.30
MM Aqua Technologies Limited	0.30	0.78	0.09	0.09
<b>Payment made for transfer of lease</b>				
TPW Engineering Limited	-	201.33	-	-
<b>Loans and advances given/(recovered)(net)</b>				
TPW Engineering Limited	-	0.61	0.22	-

<sup>^</sup>Amount is below the rounding off norm adopted by our Company

For details of the related party transactions and as reported in the Restated Consolidated Financial Information, see “*Restated Consolidated Financial Information - Annexure V- Notes to the Restated Consolidated Financial Information – Note 46 – Related Party Transactions*” beginning on page 287.

### Financing Arrangements

There have been no financing arrangements whereby our Promoters, members of the Promoter Group, Directors and their relatives (as defined in Companies Act 2013) have financed the purchase by any other person of securities of our Company during a period of six months immediately preceding the date of this Red Herring Prospectus.

### Weighted average price at which the Equity Shares were acquired by our Promoters and the Selling Shareholders in the one year preceding the date of this Red Herring Prospectus

Name	Number of Equity Shares acquired	Weighted average price of Equity Shares acquired in the last one year (in ₹) <sup>*</sup>
<b>Promoters</b>		
Madan Mohan Mohanka	8,663,159	225.00
Mehul Mohanka	2,003,315	0.02
Wagner Limited**	8,692,281	172.57

<sup>\*</sup>As certified by SDT & Co, Chartered Accountants, by way of their certificate dated November 23, 2021

<sup>\*\*</sup>Pursuant to resolutions dated November 10, 2021 passed by our Board and Shareholders, 8,692,281 CCPP held by Wagner Limited were converted to 8,692,281 Equity Shares, For details, see “*Capital Structure- Notes to the Capital Structure – Equity Share capital history of our Company*” and “*Capital Structure - Notes to the Capital Structure – Preference Share capital history of our Company*” on pages 79 and 82. The weighted average price has been calculated taking into consideration the price at which the underlying preference shares were acquired.

### Average Cost of Acquisition of Equity Shares

The average cost of acquisition per Equity Share to our Promoters and the Selling Shareholders as at the date of this Red Herring Prospectus is:

Name	Number of Equity Shares acquired	Average cost of Acquisition per Equity Share (in ₹) <sup>*</sup>
<b>Promoters</b>		
Madan Mohan Mohanka	8,663,159	0.53
Manish Mohanka	7,941,856	0.34

Name	Number of Equity Shares acquired	Average cost of Acquisition per Equity Share (in ₹)*
Mehul Mohanka	2,003,315	0.02
Nihal Fiscal Services Private Limited	36,553,153	1.26
<b><i>Selling Shareholders</i></b>		
<i>Promoter Selling Shareholders</i>		
Madan Mohan Mohanka	8,663,159	0.53
Manish Mohanka	7,941,856	0.34
<i>Investor Selling Shareholder</i>		
Wagner Limited	9,691,890	170.25

\* As certified by SDT & Co, Chartered Accountants, by way of their certificate dated November 23, 2021

### **Details of pre-IPO Placement**

Our Company does not contemplate any fresh issuance of Equity Shares from the date of this Red Herring Prospectus till the listing of the Equity Shares.

### **Issue of Equity Shares for consideration other than cash in the last one year**

Our Company has not issued any Equity Shares for consideration other than cash in the one year preceding the date of this Red Herring Prospectus.

### **Split / Consolidation of Equity Shares in the last one year**

Our Company has not undertaken a split or consolidation of the Equity Shares in the one year preceding the date of this Red Herring Prospectus.

## SECTION II - RISK FACTORS

An investment in Equity Shares involves a high degree of risk. You should carefully consider all the information in the Draft Red Herring Prospectus, this Red Herring Prospectus and the Prospectus, including the risks and uncertainties described below, before making an investment in the Equity Shares. If one, or a combination of any of the following risks occurs, our business, cash flows, prospects, financial condition and results of operations could suffer, the trading price of the Equity Shares could decline, and you may lose all, or part of your investment. In addition, the risks set out in this section are not exhaustive, and additional risks and uncertainties not presently known to us, or which we currently deem to be immaterial, may arise or may become material in the future.

In making an investment decision, prospective investors must rely on their own examination of us and the terms of the Offer including the merits and the risks involved. To obtain a more detailed understanding of our business, see “**Business**”, “**Financial Information**” and “**Management’s Discussion and Analysis of Financial Condition and Result of Operations**” on pages 141, 207 and 318, respectively. You should also read the section “**Forward-Looking Statements**” on page 16 for a discussion of the risks and uncertainties related to the forward-looking statements contained in this Red Herring Prospectus. Our results may differ materially from those expressed in or implied by these forward-looking statements as a result of certain factors, including the considerations described below and elsewhere in this Red Herring Prospectus.

Unless otherwise indicated or the context otherwise requires, the financial information for the three months period ended June 30, 2021 and Fiscals 2021, 2020 and 2019, included herein is derived from the Restated Consolidated Financial Information, included in this Red Herring Prospectus. For further information, see “**Financial Information**” on page 207. Unless otherwise indicated, industry and market data used in this section have been derived from the report titled, “Global Market Assessment – Select Mineral Processing Equipment” dated October 12, 2021 (the “**F&S Report**”) prepared and released by Frost & Sullivan and commissioned and paid for by our Company in connection with the Offer.

### Internal risk factors

#### Risks relating to business and operations

1. ***Our global manufacturing facilities, sales and operations expose us to the risks of doing business in foreign countries, which may adversely affect our business, financial condition and results of operations.***

Our revenue from operations outside India was ₹1,463.21 million, ₹6,961.18 million, ₹5,884.52 million and ₹5,439.55 million in the three months period ended June 30, 2021 and Fiscals 2021, 2020 and 2019, respectively, amounting to 84.48%, 86.42%, 85.92% and 85.83% of our revenue from operations in the respective Fiscals. We have manufacturing facilities located in the major global mining hubs of Chile, South Africa and Australia (*Source: F&S Report*). Further, we have substantial global operations which are undertaken through our 13 foreign Subsidiaries (including subsidiaries of our Subsidiaries) and 18 global sales offices in several foreign countries.

The details of the Subsidiaries that have contributed to our revenue from operations outside India for the three months period ended June 30, 2021 and Fiscals 2021, 2020 and 2019 are set out below.

*(in ₹ million, where applicable)*

Name of the entity	Revenue from operations for three months period ended June 30, 2021	% of total revenue from operations	Revenue from operations for Fiscal 2021	% of total revenue from operations	Revenue from operations for Fiscal 2020	% of total revenue from operations	Revenue from operations for Fiscal, 2019	% of total revenue from operations
Tega Industries Inc	80.76	4.66%	529.62	6.57%	318.52	4.65%	328.79	5.19%
Tega Industries Australia Pty Ltd	113.15	6.53%	439.64	5.46%	393.21	5.74%	514.30	8.12%
Tega Do Brasil Servicos Technicos Ltda	-	0%	5.37	0.07%	1.57	0.02%	10.37	0.16%
Tega Industries Canada Inc	219.06	12.65%	513.08	6.37%	504.45	7.37%	248.65	3.92%
Tega Industries Africa Pty Ltd	166.42	9.61%	1,003.35	12.46%	717.08	10.47%	763.34	12.04%

Name of the entity	Revenue from operations for three months period ended June 30, 2021	% of total revenue from operations	Revenue from operations for Fiscal 2021	% of total revenue from operations	Revenue from operations for Fiscal 2020	% of total revenue from operations	Revenue from operations for Fiscal, 2019	% of total revenue from operations
Tega Scanning Solution Inc. <sup>^</sup>	-	0%	-	0%	-	0%	6.28	0.10%
Tega Holdings Pte Ltd	119.73	6.91%	508.82	6.32%	1,162.64	16.98%	1,072.12	16.92%
Losugen Pty Ltd	83.18	4.80%	279.64	3.47%	337.57	4.93%	466.07	7.35%
Tega Industries Chile SpA <sup>*</sup>	294.43	17.00%	1,827.37	22.69%	1,401.26	20.46%	1,018.54	16.07%

<sup>\*</sup>Includes consolidated financial information related to Tega Industries Chile SpA and its subsidiaries, i.e., Edoctum S.A. and Edoctum Peru S.A.

<sup>^</sup>The Company divested its stake in Tega Scannings Solution Inc with effect from January 15, 2019.

Our global operations are subject to, among other risks and uncertainties, the following:

- Social, political, geopolitical conditions and adverse weather conditions, such as natural disasters, civil disturbance, terrorist attacks, war or other military action would affect our business and operations. For instance, such a disruption may prevent us from production or delivery of our products to our customers.
- Economic and financial conditions, including potential hyperinflationary conditions, any instability of credit markets, foreign currency fluctuations and controls, particularly the ability to repatriate funds to India and to any other countries would affect our business and operations.
- Compliance with a variety of local laws and regulations, which may be materially different than those to which we are subject in India, including legal constraints on ownership and corporate structure, environmental, health, safety, labour and accounting laws, may impose onerous and expensive obligations on our Company and our foreign subsidiaries.
- Changes in local laws, regulations or policies, including restrictions on trade, unfavourable labour regulations, tax policies or economic sanctions, intellectual property enforcement issues and changes in foreign trade and investment policies, may be difficult to predict and may affect the way in which we manage our operations in the countries in which we operate.
- Potential violations of local laws including anti-bribery laws, may cause difficulty in managing foreign operations, as well as significant consequences to us if those laws are violated.
- Difficulties in organizing a skilled workforce for efficient operations and coordinating with local authorities and representatives to fully understand and address local labour and business requirements may cause difficulty in hiring and retaining our workforce in the countries in which we operate.

In addition to the risks associated with global operations in general, our global manufacturing operations are subject to risks that are specific to each foreign country where our manufacturing facilities are located, being Chile, South Africa and Australia. Chile and South Africa have experienced periods of political uncertainty and social unrest in the past, such as the recent protests in Chile in 2019-20. Pursuant to these protests, the National Congress of Chile agreed to hold a referendum wherein a majority of the citizens voted in favour of a new constitution, which may introduce changes, including, decentralization of power and measure to support labour welfare. Introduction of any unfavourable measures and uncertainty in relation to the political stability in Chile may disrupt our operations, increase or compliance costs, reduce our workforce and adversely affect our business. Further, we have faced challenges in establishing our manufacturing facilities in these countries such as language barriers, understanding local laws and hiring a skilled workforce and we cannot assure you that we will not encounter further challenges in maintaining and/or expanding our operations in these countries. For instance, while establishing our operations in Chile, we were faced with language barriers which were overcome by specifically hiring employees with fluency in English language and training the employees which have been deployed from India in Spanish language to facilitate effective communication with customers, authorities and other relevant parties.

To the extent that we are unable to effectively manage our international manufacturing and other operations and related risks, we may be unable to grow or maintain our manufacturing capabilities, sales and assets, or we may be subject to additional unanticipated costs or legal or regulatory action. As a consequence, our prospects, business, financial condition and results of operations may be adversely affected.

**2. *Any failure to expand or effectively manage our sales and distribution network, both in India and overseas, could have an adverse effect on our business, financial condition and results of operations.***

We operate on a direct sales model and presently have an in-house sales and distribution network of 18 global and 14 domestic sales offices close to key customers. Further, as of June 30, 2021, we have a sales and services team, comprising 155 full time employees across the globe. We depend on our regional sales and marketing teams to interact with potential customers, develop an understanding of their operations, facilitate development of suitable customized products and over time establish an on-going relationship with them. Further, our sales and marketing teams are responsible for managing our existing customers and identifying their additional needs to increase our share of our existing customers' wallets. While we seek to retain and hire qualified employees with relevant experience and knowledge of the local markets where they operate, we cannot assure you our sales and marketing teams will be able to identify and successfully add new customers or identify additional needs of our existing customers, or effectively manage our existing sales network.

Moreover, our competitors may engage dealers and distributors who may be more in number as compared to our employees or have better penetration in the relevant local markets, thereby limiting our ability to expand our network. Maintaining a network of dealers and distributors may require our competitors to incur lesser costs as compared to the costs incurred by us for maintaining our sales and distribution network of employees, which involves costs such as costs of hiring and training employees, completing local formalities and ensuring compliance with applicable local employment and labour laws, processing visas or entry permits, paying employment benefits in addition to periodic salaries and developing and maintaining infrastructure such as office space and equipment. Further, the third-party dealers and distributors may have a greater ability to promote, sell and market products as compared to our employees by engaging sub-dealers, retailers and contractors and expanding their network more quickly and effectively. We may not be able to expand our sales and distribution network at the required pace, or in response to our competitors and may incur significant compliance and other costs, as discussed above, for implementing any expansion.

We may be unable to maintain a stable and reliable sales and distribution network at all times or expand our network in the future, which could adversely affect our business, financial condition and results of operations.

**3. *We are dependent on third party logistic and support service providers for the delivery of raw materials and finished products and any disruptions in their services including transportation services or a decrease in the quality of their services may adversely affect our business, financial condition and results of operations.***

We rely on third party logistic and support service providers including for transportation services at multiple stages of our business activities, including for procurement of raw materials from our suppliers and for transportation of our finished products from our manufacturing facilities to our customers and warehousing facilities. We generally use water and road transportation services to meet our transportation requirements. Our ability to identify and build relationships with reliable transportation partners worldwide contributes to our growth and successful management of our deliveries as well as other aspects of our operations.

We typically engage and hire globally recognized service providers through the spot contracts basis factors including cost, availability and delivery schedules. We invite fresh quotations from the relevant service providers which are negotiated separately in relation to each spot contract. Accordingly, our transportation costs may vary and are based on rates that are offered to us from time to time. Our business is also vulnerable to increased transportation costs or delivery delays due to various factors, including increase in fuel costs, freight rates, increase in port, road and toll taxes, shipping congestions, damage or losses of goods in transit, disruption of transportation services because of weather related problems, strikes, lock-outs, accidents, inadequacies in waterways and road infrastructure, currency fluctuations, changes in tariff or import policies, political uncertainty or other similar events.



We may face transportation risks including damage or losses of goods in transit, delay in deliveries to our customers etc. due to loss or pilferage, which we may not be able to fully recover from our service provider or from our insurance coverage. Further, while we adjust freight costs in the cost of products sold to our customers, we bear transportation risk for the duration of transit. In addition, we may be required to replace a service provider if its services do not meet our safety, quality or performance standards or the partner's non-compliance with applicable laws or if it should unexpectedly discontinue operations due to reasons beyond its or our control. Any prolonged disruption or unavailability of such facilities in a timely manner could result in delays or inability to deliver our products to our customers, or may require us to look for alternative means of transportation which may not be cost or time efficient, thereby adversely affecting our operations, profitability, reputation and market position.

Our operations and profitability are dependent upon the availability of reliable logistic and support services in a timely and cost efficient manner and any disruption in these services including transportation services or increase in their cost may affect our business, financial condition and results of operations.

**4. *Our Statutory Auditors have included an emphasis of matter regarding the accounting treatment of certain equity shares and CCPP in the auditors' reports on our special purpose interim consolidated financial statements for the three months period ended June 30, 2021 and the audited consolidated financial statements for Fiscal 2021 and in the examination report on the Restated Consolidated Financial Information.***

In the examination report on the Restated Consolidated Financial Information and auditor's report on special purpose interim consolidated financial statements as at and for the three months period ended June 30, 2021 and auditor's report on consolidated financial statements for FY 2021, the Statutory Auditors have drawn attention to the accounting treatment of certain equity shares and compulsory convertible participatory preference shares ("CCPP") presented as equity share capital and preference share capital, respectively and the premium thereon presented under securities premium account in the Restated Consolidated Financial Information, in accordance with the requirements of the Companies Act, 2013. The Auditor noted that such presentation and measurement is not in accordance with Ind AS 32 'Financial Instruments: Presentation' and Ind AS 109 'Financial Instruments' which requires the presentation of these equity shares, CCPP and the securities premium as a financial liability in its entirety, given the obligation on the holding company to buy-back these equity shares and CCPP from the holders and subsequent changes in measurement of financial liability to be recognised in the Restated Consolidated Statement of Profit and Loss. Further, the relevant disclosures required under Ind AS 107 'Financial Instruments: Disclosures' and under Ind AS 1 'Presentation of financial statements' for these equity shares and CCPP have not been made in the Restated Consolidated Financial Information in view of these reasons.

Further, the Statutory Auditors have observed in the notes to the Restated Consolidated Financial Information that if the equity shares and CCPP were classified and measured as per Ind AS 32 and Ind AS 109, the total liabilities would be higher by ₹2,492.21 million for the three months period ended June 30, 2021, ₹2,390.68 million for Fiscal 2021, ₹1,821.34 million for Fiscal 2020 and ₹1,629.89 million for Fiscal 2019 and profit before tax would be lower by ₹101.53 million for the three months period ended June 30, 2021, ₹569.34 million for Fiscal 2021, ₹191.45 million for Fiscal 2020 and ₹99.99 million for Fiscal 2019. The Statutory Auditors have not modified their opinion in this regard. As on the date of this Red Herring Prospectus, pursuant to resolutions dated November 10, 2021 passed by our Board and Shareholders, 8,692,281 CCPP held by Wagner Limited were converted to 8,692,281 Equity Shares. For details, see "*Capital Structure- Notes to the Capital Structure – Equity Share capital history of our Company*" and "*Capital Structure - Notes to the Capital Structure – Preference Share capital history of our Company*" on pages 79 and 82.

**5. *We have voluntarily approached the RBI in relation to certain delays in filing of Form FC-GPR and Form ESOP by our Company in the past and cannot assure you that these matters will be resolved in a timely manner.***

The Foreign Exchange Management (Transfer or Issue of Security by a Person Resident Outside India) Regulations, 2000 require a company to report any issuance of shares or convertible debentures in accordance with these regulations in Form FC-GPR within 30 days of such issuance. Our Company inadvertently failed to file Form FC-GPR for the issuance of CCPP and bonus shares to Wagner Limited on May 11, 2011 and October 5, 2013, respectively. We have *suo moto* filed a compounding application

before the RBI on August 6, 2021 and will take necessary steps as the RBI may direct. We received a letter dated September 8, 2021 from RBI regarding an incremental query on the valuation of bonus shares issued to Wagner Limited and our Company has submitted its response on September 10, 2021, as appropriate.

Further, in the past, there have been inadvertent lapses by our Company in relation to RBI related filings for ESOPs granted on four instances between 2011 to 2015 to certain of our non-resident employees, at the time. Our Company inadvertently failed to file Form ESOP within 30 days of such ESOP grants in relation to all ESOP grants during the above mentioned period. Our Company has approached the RBI and in accordance with guidance from our AD bank, we have initiated the process of sequential submission of the ESOP forms, with the filing of the first such form on August 10, 2021, which was rejected for certain technical reasons requiring our Company to make few modifications to the form. Accordingly, we have resubmitted the first ESOP form with such modifications on September 8, 2021 and the remaining three forms in a sequential manner. The RBI vide its letter dated October 27, 2021 has acknowledged the aforesaid forms submitted by us subject to the filing of an application by our Company for compounding of the aforesaid contravention. Accordingly, we have filed a compounding application before the RBI on November 1, 2021 and will take necessary steps as the RBI may direct.

Pending regularisation of the above delays, which came to our attention during recent review of our internal records, it is not possible to quantify the extent to which penalty, if any, may materialise on the Company in this regard, or whether this will be regularised in a timely manner.

**6. *Any shortfall or delay in the supply of our raw materials or an increase in our raw material costs, may adversely affect the pricing and supply of our products and have an adverse effect on our business, results of operations and financial condition.***

Our business depends on our ability to attract and retain third party suppliers of raw material. Discontinuation of production by these suppliers or a failure of these suppliers to adhere to any delivery schedule or the required quality or quantity could hamper our production schedule and therefore affect our business and results of operations. This dependence may also adversely affect the availability of key materials at reasonable prices thus affecting our margins and may have an adverse effect on our business, results of operations and financial condition. There can be no assurance that strong demand, capacity limitations or other problems experienced by our suppliers will not result in shortages or delays in their supply of raw materials to us.

The predominant raw material used for manufacturing our products is rubber compound, which we manufacture in India from primary raw materials including carbon black, high grade natural rubber, polyurethane rubber and styrene-butadiene rubber. Our Company also exports the rubber compound manufactured by us as an intermediate raw material to our Subsidiaries, Tega Chile and Tega Africa, to ensure quality consistency in the products manufactured at their manufacturing facilities. Our Company exported 33%, 18%, 16% and 14% of the total rubber compound manufactured in the three months period ended June 30, 2021 and in Fiscals 2021, 2020 and 2019, while the remaining quantity was to be used for our manufacturing operations in India. The other major raw material for manufacturing our products is reinforcement including wear plates, casting and aluminum which is typically procured separately for each manufacturing facility. We procure the raw materials required for manufacturing rubber compound, such as carbon black and polybutadiene rubber, from various suppliers, which comply with our quality standards and other specifications. For instance, we import the entire quantity of polybutadiene rubber required by us from two overseas suppliers. Further, in relation to facilities located in India, we presently rely on suppliers of wear plates from Sweden alone and have recently diversified to engage suppliers in Germany. Any disruption in the supply from these suppliers may materially affect our production as we may not be able to engage alternate suppliers that comply with our required quality standards on similar terms, costs or at all. There can be no assurance that we will be able to successfully diversify the number of suppliers for these raw materials or achieve an adequate combination of domestic and overseas suppliers or maintain our arrangements with existing suppliers on the same terms, in a timely manner, at competitive rates or at all. Further, some of the raw materials we use for our products are generated synthetically, and may be banned for use in the future, due to perceived potential environmental risks and adverse effects on human health. For instance, MOCA and hexavalent zinc, each a synthetic material used by us is not in compliance with the requirements of the Restriction of Hazardous Substances Directive effected by the members of the European Commission and accordingly banned in certain countries where we export our products. Any raw materials, which may be banned in the future, for

environment, health, safety or public law and policy concerns, would require us to invest significant time and resources to redesign some or a significant number of our products and seek suitable alternative raw materials, which we may not be able to procure at competitive rates or at all.

Raw material supply and pricing can be volatile due to a number of factors beyond our control, including the ability of suppliers to manufacture such raw materials, global demand and supply, general economic and political conditions, transportation and labour costs, labour unrest, natural disasters, lockdowns and curfews, competition, import duties, tariffs and currency exchange rates. For instance, prices of crude oil and petroleum, which are used for producing certain of our raw materials such as carbon black are volatile and depend on global demand-supply dynamics, as well as domestic output and import volumes and any increase in their prices would lead to increases in the price of our raw materials. Any significant increase in raw material costs could result in an increase in our total expenses, which we may not be able to pass on to our customers, which may in turn adversely impact our financial condition and results of operations.

7. ***We are dependent on a few key suppliers of certain raw materials and do not have long term contracts or exclusive arrangements with these key suppliers. Accordingly, the loss of, or a significant reduction in supply by, such suppliers could adversely affect our business, financial condition and results of operations.***

We procure certain of our primary raw materials, i.e. carbon black, high grade natural rubber, polyurethane rubber, styrene-butadiene rubber and wear plates from certain key suppliers which are established players in India and overseas. Since we are largely dependent on such key suppliers for a significant portion of raw material procurement, we are subject to several risks, including increases in cost of the raw materials we procure and reduced control over delivery schedules. We also face the risk that one or more of our existing suppliers may discontinue their supplies to us. The loss of any one of our key suppliers or a significant reduction in supply from such suppliers could have a material adverse effect on our business, financial condition, results of operations and future prospects.

The success of our supplier relationships depends significantly on satisfactory performance by our suppliers and fulfilment of their obligations. As our primary raw materials such as wear plates are produced in certain specific technical specifications and grades, we may face difficulty in finding alternative sources for such raw materials. There can be no assurance that there will not be a significant disruption in the supply of raw materials currently sourced by us or, in the event of a disruption, that we would be able to locate alternative suppliers of materials or third party manufacturers of comparable quality at an acceptable price, or at all, and whether such suppliers, if identified, would be able to make supplies of raw materials to us in a timely manner, or at all. Although we have not encountered any significant disruptions in the sourcing and/or supply of our raw materials, we cannot assure you that such disruptions will not occur.

Additionally, we do not currently have long term contracts or exclusive supply arrangements with any of our key suppliers and we purchase the raw materials on spot order basis. The failure of our suppliers to deliver raw material in the necessary quantities or as per the required schedule, of a specified quality/standard/specification, may adversely affect our production processes thereby giving rise to contractual penalties or liabilities, loss of customers and/or an adverse effect on our reputation, which may in turn result in an adverse effect on our business, financial condition and results of operations.

8. ***Depreciation of the Indian Rupee and exchange rate fluctuations in currencies in which we do business or have outstanding borrowings may materially and adversely impact our business, financial condition and results of operations.***

We are exposed to foreign exchange rate fluctuations (mainly in USD, CAD, AUD, EUR, SGD, ZAR, CLP, GHS, GHC) in respect of (i) revenue from overseas business in foreign denominations; (ii) our foreign currency denominated borrowings; (iii) currency translation losses for the purpose of preparing our consolidated financial statements (which are presented in Indian Rupees), on account of our global operations; and (iv) value of our foreign assets. Revenue generated from external customers from outside India (i.e. revenue earned in currencies other than INR) was ₹1,463.21 million (USD 19.86 million), ₹6,961.18 million (USD 93.94 million), ₹5,884.52 million (USD 82.82 million) and ₹5,439.55 million (USD 77.81 million) in the three months period ended June 30, 2021 and Fiscals 2021, 2020 and 2019, respectively. Further, for details of our foreign currency risk exposure, see “***Restated Consolidated Financial Information- Annexure V - Notes to the Restated Consolidated Financial Information-Note 40***” on page 274.

Our revenues, operating expenses and finance costs are influenced by the currencies of those countries where we manufacture and/or sell our products. The exchange rate between the Indian Rupee and these currencies, primarily the US\$ has fluctuated in the past and our results of operations have been impacted by such fluctuations in the past and may be impacted by such fluctuations in the future. For example, during times of strengthening of the Indian Rupee, we expect that our overseas sales and revenues will generally be negatively impacted. However, the effect of depreciation in the Indian Rupee may not be sustained or may not show an appreciable impact on our results of operations in any given financial period due to other variables impacting our business and results of operations during the same period. Moreover, as the borrowing arrangements availed by certain of our foreign Subsidiaries are foreign currency denominated, we expect that our cost of borrowing as well as our cost of raw materials and components incurred by our foreign Subsidiaries may rise during a sustained depreciation of the relevant foreign currency against the Indian Rupee.

While we seek to pass on all losses on account of foreign currency fluctuations to our customers, our ability to foresee future foreign currency fluctuations is limited. In relation to our products which are priced in foreign currencies, the strengthening of these currencies against the Indian Rupee results in gains and the weakening of these currencies results in losses for our Company. As an effort to mitigate any significant currency fluctuations, we typically agree to renegotiate/reset prices of our products on a periodic basis including adjustments on account of currency fluctuations beyond a specified range, which may vary between customers, depending on terms negotiated with such customers from time to time. The said permitted adjustments in our prices are generally effected with a prospective effect and may not be adequate to fully set-off the effect of foreign currency fluctuations, which may result, as earlier mentioned, in either losses or gains for our Company.

Our Company primarily uses derivatives to hedge its risk against foreign currency balances of borrowings, trade payables and trade receivables and contract assets. Such exposures are managed within approved policy parameters utilising foreign exchange forward contracts and options. Further, our Company also has variable interest rate loan in foreign currency. To manage its risk against interest rate movements our Company has taken an interest rate swap. Our Company has also entered into derivative contracts to hedge forecast sales and purchase transactions using forward contracts. However, any action that we may take and any amounts that we spend or invest in order to hedge the risks to our business due to fluctuations in currencies may not adequately hedge against any losses and we cannot assure you of the sufficiency of these procedures or whether the procedures we have in place will be successful in managing our foreign currency exposure.

9. ***The Investor has certain put and buy back options under the Shareholders' Agreement dated April 29, 2011, as amended ("SHA")***

In terms of the SHA, the Investor has, among others, a right to cause our Company to buy-back certain put options associated with the equity shares and CCPP held by the Investor if an initial public offering by our Company is not completed within the prescribed period, in accordance with the terms of the SHA. Further, in terms of the SHA, the CCPP were to be converted in to an equal number of Equity Shares on the happening of certain events, including the filing of a red herring prospectus for an initial public offering by our Company or on a particular date, as mutually agreed between our Company, the Investor and our Promoters. Consequently, the CCPP have been converted to Equity Shares prior to the filing of the red herring prospectus by the Company, as disclosed in the section titled, '**Capital Structure**' on page 79. The rights held by the Investor in relation to the Securities in accordance with the SHA and the details in relation to the allotment and/or transfer of the Securities to the Investor are disclosed in the sections titled, "**History and Certain Corporate Matters - Shareholders' Agreements and Other Agreements**" and "**Capital Structure**" on pages 172 and 79, respectively. There can be no assurance that we will complete the initial public offering within the prescribed period and if the date of exercising such options is not mutually extended by the parties, it may require us to buy-back the put options associated with the Securities in accordance with the SHA. These put and buy-back options have been currently extended by the parties till December 31, 2021, which may be further extended mutually by the parties. The put and buy-back options will not survive after the date of allotment of Equity Shares in the Offer as pursuant to the SHA Amendment Agreement, the SHA shall automatically stand terminated upon the date of allotment of Equity Shares pursuant to the Offer, as disclosed in "**History and Certain Corporate Matters- Shareholders' Agreements and Other Agreements**" on page 172.

**10. *Our Company, our Promoters and our Directors are involved in certain legal proceedings, and an adverse outcome in any such proceedings may adversely affect our business, financial condition and growth strategy.***

Our Company is involved in certain legal proceedings, in the ordinary course of business, which are pending at varying levels of adjudication at different forums from time to time. As per the Materiality Policy, all pending litigation involving our Company, our Subsidiaries, our Promoters and our Directors, other than criminal proceedings, statutory or regulatory actions and taxation matters, are considered “material” if the monetary amount of claim by or against the entity or person, in any such pending litigation exceeds 0.5% of the restated consolidated total profit for the year of our Company, as per the Restated Consolidated Financial Information, for the latest fiscal i.e. Fiscal 2021, amounting to ₹6.82 million, or any such litigation, an adverse outcome of which would materially and adversely affect our Company’s business, prospects, operations, financial condition or reputation, irrespective of the amount involved in such litigation. As on the date of this Red Herring Prospectus, the summary of the outstanding litigations involving the aforementioned persons/entities are as follows:

<b>Type of Litigation</b>	<b>Number of cases</b>	<b>Amount* (in ₹ million)</b>
<b>Litigation involving our Company</b>		
Criminal litigation	3 <sup>^</sup>	2.70
Material civil litigation	3	35.43
Actions by statutory or regulatory authorities	2	-
Direct and indirect tax proceedings	24	263.78
<b>Total</b>	<b>32</b>	<b>301.91</b>
<b>Litigation involving our Promoters</b>		
Actions by statutory or regulatory authorities	1	-
Direct and indirect tax proceedings	21	22.22
<b>Total</b>	<b>22</b>	<b>22.22</b>
<b>Litigation involving our Directors</b>		
Actions by statutory or regulatory authorities	1	-
Direct and indirect tax proceedings	9	2.71
<b>Total</b>	<b>10</b>	<b>2.71</b>
<b>Litigation involving our Subsidiaries</b>		
Actions by statutory or regulatory authorities	5	-
<b>Total</b>	<b>5</b>	<b>-</b>
<b>Litigation involving our Group Companies**</b>		
Nil	Nil	Nil

\*to the extent quantifiable

\*\*This comprises the pending proceedings which may have a material impact on our Company, in accordance with the Materiality Policy.

<sup>^</sup> These three criminal complaints have been filed by the Company against Tecpro Systems Ltd. under the Negotiable Instruments Act, 1881. For details, see “*Outstanding Litigation and Material Developments- Litigation involving our Company*” on page 355.

Involvement in such proceedings could divert our management’s time and attention, and consume financial resources. Further, an adverse judgment in these proceedings could have an adverse impact on our business, results of operations and financial condition. See “*Outstanding Litigation and Other Material Developments*” on page 355.

We cannot assure you that any of such proceedings will be settled in our favour or in favour of our Promoters or Directors, as applicable, or that no additional liability will arise out of these proceedings.

**11. *There are outstanding actions by statutory or regulatory authorities against our Company and Promoters. Any adverse outcome in such proceedings may have an adverse impact on our business, financial condition, results of operations and cash flows.***

There are two outstanding actions by statutory or regulatory authorities against our Company, each of which have been filed by the Inspector of Factories, Kalyani before the Additional Chief Judicial Magistrate, Kalyani, Nadia. One of these actions has been filed against one of our Promoters, Mehul Mohanka, as the then occupier of our manufacturing facility at Kalyani. These outstanding actions allege violation of certain provisions of the Factories Act, 1948 and the West Bengal Factories Rules, 1958 pursuant to inspection/ enquiry carried out by the Inspector. For details, see “*Outstanding litigation and*

**Material Developments- Outstanding actions by statutory or regulatory authorities against our Company”** on page 356. There can be no assurance that these legal proceedings will be decided in our favor or in favor of our Company or our Promoter. In addition, we cannot assure you that no additional liability will arise out of these proceedings, which may affect our business, results of operations and financial condition.

12. ***We export our products to various countries, on account of which we may be subject to significant import duties or restrictions. Further, unavailability of fiscal benefits enjoyed by us or our inability to comply with related requirements may have an adverse effect on our business and results of operations.***

Our key overseas markets include North America, South America, Africa, EMER (Europe, Middle East and Russia) and Asia Pacific. The countries in these regions impose varying import duties on our products. There can be no assurance that the import duties will not increase or new restrictions will not be imposed by such countries. Any substantial increase in such duties or imposition of new restrictions may adversely affect our business, financial condition and results of operations.

Export destination countries may also enter into free trade agreements or regional trade agreements with countries other than India. Such agreements and alteration of existing tax treaties may lead to increased competition or may even place us at a competitive disadvantage compared to manufacturers in other countries. India is also a party to, and is currently negotiating, free trade agreements with several countries and if we export our products to such countries, any revocation or alteration of those bilateral agreements may also adversely affect our ability to export. Occurrence of any of these events may adversely affect our business, financial condition and results of operations. Further, changes in import policies or an economic slowdown in countries to which we export our products may have a significant adverse impact on our business, financial condition and results of operations.

Further, the GoI notifies policies providing fiscal benefits on exports and imports from time to time and any discontinuance or non-availability of such fiscal benefits enjoyed by us or our inability to comply with related requirements may have an adverse effect on our business and results of operations. For instance, we enjoyed certain fiscal benefits under the erstwhile Merchandise Exports from India Scheme (“MEIS”), pursuant to which, we could use duty credit scrips for payment of import duty obligations or sell such duty credit scrips in the open market to other importers. However, the Ministry of Finance, GoI has withdrawn MEIS with effect from January 1, 2021 and announced a scheme for remission of duties and taxes on export products (“RoDTEP Scheme”) for exporters. Under the RoDTEP Scheme we are entitled to benefits from 0.9% to 1.4% as compared to 3% under MEIS. Further, while MEIS was eligible for exports from SEZs and exports under an advance license, the RoDTEP Scheme is not eligible for such exports. Additionally, we apply for an advance license allowing duty free import of input material used for our manufacturing activities under the Foreign Trade Policy of India 2015-2020, which imposes certain export obligations on us. We cannot assure you that we will successfully obtain such a license every time and/or will subsequently be able to comply with the requirements prescribed thereunder.

The fiscal benefits enjoyed by the Company, on a consolidated basis, on account of export and import policy during the three months period ended June 30, 2021 and Fiscals 2021, 2020 and 2019 are set out below.

*(in ₹ million, where applicable)*

Particulars	For three months period ended June 30, 2021	For year ended March 31, 2021	For year ended March 31, 2020	For year ended March 31, 2019
Revenue from Operations	1,732.07	8,055.22	6,848.47	6,337.57
Export benefit	9.80	68.36	108.16	111.49
% of Revenue from Operations	0.57%	0.85%	1.58%	1.76%
Import Benefit	10.42	50.43	50.29	33.04
% of Revenue from Operations	0.60%	0.63%	0.73%	0.52%

13. ***We have been unable to locate certain of our historical corporate records.***

Our Company was incorporated on May 15, 1976 and we have been unable to trace the following historical records in relation to certain allotments and transfers of Equity Shares in the past:

- Form-2 filed with the RoC in relation to all the allotments of Equity Shares in the period from February 17, 1977 to January 6, 1981, along with allotments made on September 30, 2004.
- Resolutions passed by the Board and/or the Shareholders of the Company in relation to certain allotments of Equity Shares in the period from February 17, 1977 to September 30, 2004.
- Certain share transfer forms in relation to transfer of Equity Shares to and by our Promoters.

For details of the above instances of allotments, see “*Capital Structure*” on page 79.

We have been unable to trace these documents despite conducting a search at our Company’s offices and the Registrar of Companies and may be unable to obtain copies of these documents in the future to ascertain details of the relevant transactions. Accordingly, reliance has been placed on opinions obtained from third party independent source and confirmations provided by our Company in respect of the missing corporate records and appropriate disclosures have been made in this Red Herring Prospectus pursuant to the due diligence of the other relevant corporate records available with our Company including the minutes of meetings of the Board, register of members, register of transfer of Equity Shares and share transfer forms in relation to transfer of Equity Shares by and to the Promoters to ascertain the information sought from the missing corporate records. Further, our Company has, through letter dated July 5, 2021, preferred a right to information application before the Public Information Officer, Registrar of Companies, West Bengal requesting the authorities to provide all the Form 2 filings and the certified copies of documents available with the Registrar of Companies in relation to our Company since its inception. We received a reply dated July 8, 2021, which was received by us on September 15, 2021 stating that the form filings made by a Company are available on the public domain of the MCA website. However, all form filings which were made physically prior to 2006 are not available on the MCA website and accordingly such filings of our Company cannot be retrieved from the MCA website. Subsequently, our Company through letter dated September 27, 2021, preferred another right to information application and received response on October 6, 2021 confirming that certain physical Form 2 filings of the Company have been destroyed in accordance with the relevant rules. Further, Aditya Tiwari & Company, Practising Company Secretary, has conducted an independent search at the RoC office and submitted a report dated July 14, 2021 to extract the Company’s form filings. While no legal proceedings or regulatory action has been initiated against our Company in relation to the unavailable filings as of the date of this Red Herring Prospectus, we cannot assure you that such proceedings or regulatory actions will not be initiated against our Company in the future in relation to the missing filings and corporate records.

**14. *Our Company will not receive any proceeds from the Offer for Sale***

The proceeds from the Offer for Sale will be paid to the Selling Shareholders. Certain of our Promoters, Madan Mohan Mohanka and Manish Mohanka and our Shareholder, Wagner Limited are selling Equity Shares in the Offer and will receive proceeds as part of the Offer for Sale in proportion of their respective portion of the Offered Shares transferred pursuant to the Offer. Accordingly, our Company will not receive any proceeds from the Offer for Sale.

**15. *We depend on our R&D efforts to improve our existing products and/or introduce new products and if our efforts do not succeed, our results of operations, growth and prospects may be adversely effected. Further, any failure to commercialize our new products may adversely impact our business, results of operations and future prospects.***

The development and commercialization of improved and/or new products is complex, time-consuming and costly, and its outcome is inherently uncertain. Accordingly, we have committed substantial effort, funds and other resources towards R&D activities. For the three months period ended June 30, 2021 and Fiscals 2021, 2020 and 2019, we have incurred research and development expenditure on a consolidated basis aggregating to ₹9.84 million, ₹37.52 million, ₹36.68 million and ₹42.42 million, respectively. Further, we currently have 36 personnel in our in-house R&D team and have invested in a customised software for structural analysis, flow analysis, 3D modelling and product selection. For further details, see “*Business - Research and Development*” on page 163. We have developed and commercialized DynaPrime and Rapido in Fiscal 2018. For details see, “*Business- Our product portfolio*” on page 149.

We cannot guarantee that the improved and/or new products we will introduce in the future will be successful or will continue to be successful, whether due to factors within or outside of our control, such as general economic conditions and failure to predict customer demand or understand market requirements. In the event that such products are unsuccessful, we may lose any or all of the investments that we have made in developing them, which could have an adverse effect on our business, results of operations and future prospects.

Further, products developed as a result of our research and development activities will only be profitable if they can be commercialized. While we have an existing track record of concept to commercialization, the process of developing new products takes a significant amount of time and investment from the stage of identification till the launch of the product. The launch of a new product is itself a complex process, the success of which depends on a wide range of factors, including the production readiness of our manufacturing facilities and manufacturing processes and those of our suppliers, as well as factors related to tooling, equipment, employees and initial product quality. If we are unable to bring enough products to market, or if products are brought to market after competing products are commercialized, our growth strategy may not be successful, and our business would be adversely affected. For instance, we are currently working on introducing combination linings in single equipment but cannot assure you that we will be successful in launching such products and also profitable commercialising their use by our customers. Further, we also incur costs in obtaining patents for our products and operations. For details see, “*-Our efforts in obtaining and protecting our patents may be costly and unsuccessful, which may have an adverse effect on our business and results of operations*” below.

At any point in time due to either failure or commercial unviability of our product, the research and development activities related to such product may be suspended or discontinued. Our ongoing investments in new product launches and research and development for future products could result in higher costs without a proportionate increase in revenues. There can be no assurance that our expenditure on research and development activities will yield proportionate results or that commercially viable products may be developed or launched as a result of such research and development activities.

**16. *Our inability to identify and adapt to evolving industry trends, technological advancements, consumer preferences may adversely affect our business, financial condition and results of operations.***

Changes in industry trends or competitive technologies or consumer preferences may render certain of our products obsolete, standardised or less attractive. Our ability to anticipate changes in industry trends, technology and customer preferences and to successfully develop and introduce new and enhanced products to cater to our current and potential customers in a timely manner, is a significant factor in our ability to remain competitive. For instance, as a response to the industry trend of moving towards the rubber-metal composite mill in the mining industry, we launched our flagship product, DynaPrime in 2018. However, we may not be able to identify such upcoming industry trends in a timely manner, at all or respond to such industry trends by launching suitable products.

Customer preferences, especially in many developed markets, appear to be moving in favour of environmentally friendly technologies such as renewables and electrical cars. These developments may boost the global demand for copper. Within the Indian market, developments such as allowing commercial coal mining and the introduction of the Mines and Minerals (Development and Regulation) Amendment Bill, 2021 may lead to increased mineral production in India (*Source: F&S Report*). For more details, see “*Industry Overview*” on page 108. Our ability to anticipate industry trends, changes in technology or consumer preferences, successfully predict, develop and bring to market new and innovative and/or improved products, may have a significant impact on our market competitiveness. Further, unexpected advances in a given technology in the market or difficulties encountered in developing a new technology internally, could prevent us from seizing opportunities relating to technological breakthroughs and as a result could impact our competitive positioning, growth and profitability. If we are unable to maintain our competitive advantage through innovation or if we do not sustain our ability to meet customer requirements relative to technology, or acquire new and compelling products that capitalize upon new technologies in response to consumer preferences, our business, financial condition and results of operations could be materially adversely affected.

**17. *Certain of our immovable properties and machinery in India and overseas are taken on lease by us. If we are unable to renew existing leases or relocate our operations on commercially reasonable terms, there may be an adverse effect.***



Our manufacturing facilities at Kalyani, West Bengal and Dahej, Gujarat, Chile and Australia are located on land held by us on leasehold basis. As on the date of this Red Herring Prospectus, we have 37 leasehold immovable properties located in India and 23 leasehold properties located overseas, including branch offices, administrative offices, warehouses and guest houses. Our Company has also taken 7 machineries including forklifts on lease for our operations in India. If we are unable to renew certain or all of these leases on commercially reasonable terms, we may suffer a disruption in our operations or be unable to continue to operate from those locations in the future (and may, to that extent, need to revise our raw material sourcing, product manufacturing and raw material and product inventory schedules and/or incur significant costs to relocate or expand our operations elsewhere in order to continue to honour our commitments to our customers).

In addition, the terms of certain of our leases require us (as the lessee) to incur certain repair and maintenance costs from time to time and to bear utility charges, and include conditions which may restrict our operational flexibility in certain respects, for instance, requiring us to obtain the lessor's prior consent for certain actions (including making significant structural alterations to the factory building, which may be required if we were to undertake a significant expansion in the future, or for undertaking a corporate restructuring or to sublet, transfer, assign, charge or mortgage such properties).

Failure to identify suitable premises for relocation of existing properties, if required, or in relation to new or proposed properties we may purchase, in time or at all, may have an adverse effect on our production and supply chain, the pace of our projected growth as well as our business and results of operations.

18. ***We earn repeat revenues from our customers, specially our marquee customers, on the basis of the long-term relationships that we have established with them. The loss of any of our long-term marquee customers or significant reduction in repeat orders from such marquee customers may adversely affect our business, results of operations and financial condition.***

We are dependent on the long-term relationships that we have established with our customers, specially our marquee customers, as we primarily cater to the after-market products and services needs of our customers, who are typically in the mining beneficiation industry. The after-market spend for a mining mill comprises expenses including costs of wear and separation parts, grinding media, power consumption, liners and other regular operating expenses, which leads to recurring demand and repeat revenues for us. As a result, 76.28%, 74.29%, 75.43% and 79.72% of our sale of product and services in the three months period ended June 30, 2021 and Fiscals 2021, 2020 and 2019 resulted from repeat orders of spares.

Further, the details of the revenue from operations earned from our top 20 customers is set out below.

Particulars	Revenue from operations				% of total revenue from operations			
	Three months period ended June 30, 2021	FY 2021	FY 2020	FY 2019	Three months period ended June 30, 2021	FY 2021	FY 2020	FY 2019
<b>Total (A+B)</b>	<b>894.46</b>	<b>3,626.00</b>	<b>2,896.15</b>	<b>2,174.82</b>	<b>52.75%</b>	<b>46.08%</b>	<b>43.61%</b>	<b>35.40%</b>
A. Spares	535.15	2,680.31	2,181.38	1,740.07	31.56%	34.06%	32.85%	28.32%
B. Conversion	359.31	945.69	714.77	434.75	21.19%	12.02%	10.76%	7.08%

If we are unable to maintain constant dialogue with our customers, understand the recurring needs of their operations or deliver the spares to replace the parts in a timely manner and of a certain quality, we may not be able to retain our long-term relationship with them and lose their repeat orders to our competitors. Any significant loss of our repeat orders will impact our order book and limit our ability to accurately forecast the demand for our products and services. Additionally, we may incur significant expense in preparing to meet anticipated repeat orders that may not be recovered. Further, if our marquee customers do not successfully expand or scale-up their mining operations, we may be prevented from capitalising on new growth opportunities by leveraging our long-term relationship with them.

We seek to leverage our direct sales model and dedicated regional teams to develop long-term relationships with our more recently acquired customers to gain their repeat business as well. If we are unable to develop a deep understanding of their after-market needs or develop products and services that

will meet their expectations and requirements, we may not establish a long-term relationship with these customers, which may adversely affect our prospects and revenue from repeat orders in the subsequent years. We cannot assure you that we will be able to maintain historic levels of repeat business from our long-term and/or marquee customers or gain the repeat business of our newer customers, which may adversely affect our business, financial conditions and revenues from operations.

**19. *Activities involving our manufacturing process can be dangerous and can cause injury to people or property in certain circumstances. A significant disruption at any of our manufacturing facilities may adversely affect our production schedules, costs, sales and ability to meet customer demand.***

Manufacturing activities by nature may be hazardous. Our business requires individuals to work under potentially dangerous circumstances or with flammable materials. Despite compliance with requisite safety requirements and standards, our operations are subject to significant hazards, including:

- explosions;
- fires;
- mechanical failures and other operational problems;
- inclement weather and natural disasters;
- discharges or releases of hazardous substances, chemicals or gases; and
- other environmental risks.

These hazards can cause personal injury and loss of life, catastrophic damage or destruction of property and equipment as well as environmental damage, which could result in a suspension of operations and the imposition of civil or criminal liabilities. However, we could also face claims and litigation, in India or overseas, filed on behalf of persons alleging injury predominantly as a result of occupational exposure to hazards at our facilities. If these claims and lawsuits, individually or in the aggregate, are resolved against us, our business, results of operations and financial condition could be adversely affected.

**20. *We have significant power, water and fuel requirements and any disruption in supplies could increase our production costs and adversely affect our results of operations.***

We require substantial power, water and fuel for our manufacturing facilities. In particular, power and fuel costs represent a significant portion of the production costs for our operations. For the three months period ended June 30, 2021 and FY 2021, FY 2020, and FY 2019, power and fuel expenses costs were ₹60.61 million, ₹213.20 million, ₹215.30 million and ₹210.46 million, constituting 3.50%, 2.65%, 3.14% and 3.32%, respectively, of our revenue from operations. If power and fuel costs were to rise, or if power and fuel supplies or supply arrangements were disrupted, our profitability could decline.

If our power sources are disrupted, we may have to rely on captive generators, which may not be able to consistently meet our requirements or incur additional costs towards sourcing additional power and steam. The cost of electricity from state electricity boards could be significantly higher, thereby adversely affecting our cost of production and profitability. Further, if for any reason such electricity is not available, we may need to shut down our plants until an adequate supply of electricity is restored. Interruptions of electricity supply can also result in production shutdowns, increased costs associated with restarting production and the loss of production in progress. Any of the foregoing situations could adversely affect our production costs and results of operations.

**21. *We provide customised products and solutions to our customers and depend on our ability to identify and understand our customers' preferences and requirements. Any failure to do so or subsequent change in our customers' preferences may adversely affect our cash flow, business and results of operations.***

The success of our business depends to a large extent on our ability to provide customised products designed to suit the specific needs of our customers rather than providing standardized products by taking into account multiple characteristics of the application including type of ore, ore size, tonnage, breakage rate, power or rotational speed, pH, temperature, humidity, size, distribution and trajectory, sound levels and health and safety standards. Investing in product innovation and customisation involves significant

investment of time and resources towards understanding the requirements of our customers such as design improvements, cost savings, durability etc. However, there is no assurance that we will be able to produce the customised product to the satisfaction of the customer, or at all, which may adversely affect our cash flow, business, financial condition and results of operations.

We dedicate significant time, manpower and financial and other resources to our product customisation efforts in order to maintain our competitive position. Any or all of the customisations to our products as requested by our customers may result in changes in product specifications and difficulties in predicting the time to be taken for the development of a new product. Additionally, enhancements/refinements are typically complex and are normally elongated over a period of time as they include several phases from conceptualization to development followed by field testing and trials. Further, the customers may not purchase our products, customised as per their requirements, to the extent earlier anticipated, or at all, and may require us to undertake further research and innovation before purchasing our products. As many of our operating expenses are relatively fixed, such unanticipated change in customer demand or preference may adversely affect our cash flow, business and results of operations.

**22. *The extent to which COVID-19 affects our business, results of operations and financial condition will depend on future developments, which are uncertain and cannot be predicted.***

The COVID-19 pandemic has adversely impacted the global economy. The World Health Organization declared the outbreak of COVID-19 as a public health emergency of international concern on January 30, 2020 and a pandemic on March 11, 2020. The Government of India announced a nation-wide lockdown on March 23, 2020 and imposed several restrictions, such as imposing country-wide lockdowns, as well as restrictions on travel and business operations, which were subsequently relaxed in a phased manner across the country. Resurgence of COVID-19 in India in April 2021 led to further lockdowns in various regions of India and temporary closure of businesses. While the lockdowns have subsequently been relaxed, the scope, duration, and frequency of such measures and the adverse effects of COVID-19 remain uncertain and could be severe. Similarly, Australia, South Africa and Chile also imposed certain restriction, including restrictions on movement, travel and business activities which are relaxed in accordance with the instructions of the relevant authorities in the respective jurisdictions. We cannot predict when any of the restrictions currently in place will be relaxed or when further restrictions will be announced.

However, COVID-19 had limited impact on the mills and mining industry, since it was declared as an essential service in various countries globally. Mines were running continuously since temporary shutdowns of mines are expensive and therefore there was a resilient demand for critical mill consumables for its regular operations. In India, as our products are categorised as “essential goods”, we were able to continue manufacturing operations during the lockdown. Although, we faced a temporary logistical issues in terms of limited availability of labour, logistics and supply chain constraints. Our exports and production in our domestic facilities were temporarily disrupted in March-April, 2020. Further, our plants in Chile, South Africa and Australia remained functional except for a temporary halt at our plant in South Africa in March-April 2020. For details of the temporary disruption faced by our manufacturing units, see ‘*Business-Impact of Covid*’ on page 149.

We have implemented greater safety procedures and requirements at our manufacturing facilities to meet the relevant government’s requirement on sanitisation, and social distancing. However, due to limited availability of labour, logistics and supply chain constraints, our manufacturing facilities were initially operating at sub-optimal capacity utilization but subsequently, our capacity utilization has improved, raw material suppliers have resumed operations and supply and logistics have become more regular. We have not terminated any lease deed or laid-off any employees and have not withheld any payments to employees as a consequence of the COVID-19.

We have assessed the possible impact of COVID-19 and have been largely unaffected until now however, the scale of the COVID-19 pandemic and the extent to which the local and global community has been impacted, our quarterly and annual revenue growth rates and expenses as a percentage of our revenues, may differ significantly from our historical rates, and our future operating results may fall below expectations. The impact of the pandemic on our business, operations and future financial performance include, but are not limited to the following:

- our ability to travel, interact with potential customers, pursue partnerships and other business transactions;

- our inability to source key raw materials as a result of the temporary or permanent closure of the facilities of suppliers of our key raw materials;
- a portion of our workforce being unable to work, including because of travel or government restrictions in connection with Covid, including stay at home order, which could result in a slowdown in our operations;
- delays in orders or delivery of orders, which may negatively impact our cash conversion cycle and ability to convert our backlog into cash;
- inability to collect full or partial payments from customers due to deterioration in customer liquidity;
- uncertainty as to what conditions must be satisfied before government authorities completely lift lockdown orders; and
- the potential negative impact on the health of our employees, particularly if a significant number of them are afflicted by Covid, could result in a deterioration in our ability to ensure business continuity during this disruption.

Further, we export our products to different geographies globally. The effects of COVID-19 in India and the geographies we operate in may last for different duration or have different magnitude in different countries which may make it difficult for us to normalise the operations.

The extent to which COVID-19 impacts our business and results will depend on future developments, which are highly uncertain and cannot be predicted, such as new information which may emerge concerning the severity of the coronavirus and the actions taken globally to contain the coronavirus or treat its impact, among others. In addition, we cannot predict the impact that the COVID-19 pandemic will have on our customers, suppliers and other business partners, and each of their financial conditions; however, any material effect on these parties could adversely impact us. To the extent that the Covid pandemic adversely affects our business and operations, it may also have the effect of heightening many of the other risks described in this section.

**23. *We are entitled to certain tax benefits under the Special Economic Zones Act, 2005 (“SEZ Act”) and other fiscal statutes. These tax benefits are available for a definite period of time, which, on expiry or if withdrawn prematurely, may adversely affect our business, financial condition, results of operations and prospects.***

We are entitled to claim certain direct tax exemptions or reimbursements on account of our manufacturing facility in Dahej, Gujarat being situated in SEZs. For instance, we are entitled to exemptions from (or refunds on account of) the following duties and levies:

- duty on import/domestic procurement of goods for development, operation and maintenance of SEZ operations; and
- payment of GST for goods brought from a DTA into the SEZ for its authorized operations.

The details of the special tax benefits availed by the Company for the three months period ended June 30, 2021 and Fiscals 2021, 2020 and 2019 are set out below.

*(in ₹ million, where applicable)*

Fiscal Year	Relevant provisions of the Income Tax Act			Total	Total Income	% of Total Income
	80IA	10AA	80JJAA			
Fiscal 2019	48.49	152.36	1.03	201.88	6,430.13	3.14%
Fiscal 2020	48.86	222.30	0.85	272.01	6,955.42	3.91%
Fiscal 2021	-	-	0.85	0.85	8,566.84	0.01%
Three months period ended June 30, 2021	-	-	-	-	1,793.86	N/A

For further details, see “*Statement of Special Tax Benefits*” on page 103. Our profitability will be affected to the extent that such benefits are not available beyond the periods currently contemplated. Our

profitability may be further affected in the future if any benefit under the statute is reduced or withdrawn prematurely or if we are subject to any dispute with the tax authorities in relation to these benefits.

Further, under the SEZ Act, we are required to maintain positive net foreign exchange earning that is to be calculated cumulatively for a period of five years from the commencement of our operations carried out from the SEZs. If we fail to maintain positive net foreign exchange earnings, we would be subject to penalties as prescribed under the Foreign Trade (Development and Regulation) Act, 1992, including penalties of up to five times the value of the goods in respect of which contravention is made. In the event that any adverse development in the law or the manner of its implementation affect our ability to benefit from these tax incentives, our business, financial condition, results of operations and prospects may be adversely affected.

**24. *Our Statutory Auditors have included certain emphasis of matters in the auditors' reports on our special purpose interim consolidated financial statements for the three months period ended June 30, 2021 and our audited consolidated financial statements for the last three fiscal years and in the examination report on the Restated Consolidated Financial Information. Further, the auditors have included certain observations in their reporting under Companies (Auditors Report) Order, 2016 ("CARO")***

The examination report on the Restated Consolidated Financial Information and Annexure VI- Statement of Adjustments to the Audited Special Purpose Interim Consolidated Financial Statements as at and for the three months period ended June 30, 2021 and Audited Consolidated Financial Statements as at and for the years ended March 31, 2021, March 31, 2020 and March 31, 2019 included therein and the auditors' reports on our special purpose interim consolidated financial statements for the three months period ended June 30, 2021 and audited consolidated financial statements for FY 2019, FY 2020 and FY 2021, to the extent applicable, contain the following emphasis of matters on the following matters:

- In the examination report on the Restated Consolidated Financial Information and auditor's report on special purpose interim consolidated financial statements as at and for the three months period ended June 30, 2021 and auditor's report on consolidated financial statements for FY 2021, the Statutory Auditors have drawn attention to the accounting treatment of certain equity shares and compulsory convertible participatory preference shares ("CCPP") presented as equity share capital and preference share capital, respectively and the premium thereon presented under securities premium account in the Restated Consolidated Financial Information, in accordance with the requirements of the Companies Act, 2013. For details, see "***Our Statutory Auditors have included an emphasis of matter regarding the accounting treatment of certain equity shares and CCPP in the auditors' reports on our special purpose interim consolidated financial statements for the three months period ended June 30, 2021 and the audited consolidated financial statements for Fiscal 2021 and in the examination report on the Restated Consolidated Financial Information.***" above.
- In the three months period ended June 30, 2021, the Statutory Auditors have drawn attention to non-settlement of foreign currency payables as at June 30, 2021 amounting to ₹5.84 million and ₹0.47 million outstanding beyond the time period permitted under the Master Direction on Import of Goods and Services vide FED Master Direction No. 17/ 2016-17 dated January 1, 2016 (as amended), issued by RBI, with respect to Merchanting Trade Transaction (MTT) and other import dues respectively. Our Company has submitted an application to AD Bank seeking RBI approval for extension of time for making payment for aforesaid foreign currency payables other than amount outstanding with respect to MTT, for which approval for making payment has been sought. This emphasis of matter has been reproduced in the examination report on Restated Consolidated Financial Information.
- In FY 2020, the Statutory Auditors have drawn attention to the audit report on the consolidated financial statements of Tega Chile in relation to, i) deferred tax asset arising from accumulated tax losses, recovery of which will depend on the compliance with the respective business plan approved by the Board; ii) negative working capital. The Statutory Auditors have not modified their opinion in this regard. The quantum of such deferred tax as on March 31, 2020 was CLP 2273.885 million (equivalent to ₹215.15 million). This Emphasis of matter has been reproduced in the examination report on Restated Consolidated Financial Information.

- In FY 2019, the Statutory Auditors have drawn attention to the audit report on the consolidated financial statements of Tega Chile in relation to negative working capital and equity deficit, introducing a significant doubt on the ability of Tega Chile to continue as a going concern. The Statutory Auditors have not modified their opinion in this regard. This Emphasis of matter has been reproduced in the examination report on Restated Consolidated Financial Information.

In relation to Tega Chile, the negative working capital reported as on March 31, 2020 and March 31, 2019 was due to its current liabilities exceeding its current assets on account of higher payables which included payables to certain of our Subsidiaries and also to our Company. As at March 31, 2021, Tega Chile reported a positive working capital of CLP 1,688.56 (equivalent to ₹168.75 million).

Further, the auditor's have issued a modified opinion on the report on special purpose interim consolidated financial statements as at and for the three months period ended June 30, 2021, modified with regard to non-furnishing of comparative figures, which are not being presented in the Restated Consolidated Financial Information as per the option of not presenting the comparative figures information availed by the Company as per the SEBI ICDR Regulation. The Restated Consolidated Financial Information did not require any adjustments for this matter. Our auditors have also included certain observations in their reporting under the Company (Auditor's Report) Order, 2016. For details, see "*Restated Consolidated Financial Information - Annexure VI to Restated Consolidated Financial Information*" on page 306.

There is no assurance that our audit reports for any future fiscal periods will not contain qualifications, matters of emphasis or other observations which affect our results of operations in such future periods. For further details, see, "*Restated Consolidated Financial Information*" and "*Management's Discussion and Analysis of Financial Condition and Results of Operations*" on pages 207 and 318, respectively.

**25. *Our contingent liabilities could adversely affect our financial condition if they materialise.***

As per our Restated Consolidated Financial Information, as of June 30, 2021, our contingent liabilities, that have not been provided for are as set out in the table below:

<i>(in ₹ million, except otherwise stated)</i>	
<b>Particulars</b>	<b>As of June 30, 2021</b>
Disputed Excise duty	14.75
Disputed Service Tax	3.08
Disputed Income Tax	64.54
Disputed sales tax	6.56
Pending finalisation of legal / arbitration proceedings	4.05
The Company stands as surety in connection with General Bond executed by MM Aqua Technologies Limited	1.50

If any of these contingent liabilities materialises, our results of operations and financial condition may be adversely affected.

**26. *One of our Promoters, Nihal Financial Services Private Limited will undergo a corporate restructuring resulting in, amongst others, a change in its equity shareholding in our Company. We cannot assure you that the relevant approvals in relation to such corporate restructuring will be obtained or estimate the time involved in its implementation.***

Our corporate Promoter, NFSPL, has filed a scheme of amalgamation dated July 16, 2021 ("**Scheme**") before the National Company Law Tribunal, Kolkata Bench at Kolkata ("**NCLT**"). Under the Scheme, NFSPL proposes to undergo a corporate restructuring wherein, i) Marudhar Food and Credit Limited ("**Marudhar**"), presently our Promoter Group entity, will be amalgamated in to NFSPL, on a going concern basis; and ii) MM Aqua Technologies Limited and Maple Orgtech (India) Limited, each a subsidiary of NFSPL and presently our Promoter Group entities, will be transferred and de-merged from NFSPL to M.M. Group Holdings Private Limited, on a going concern basis.

On approval of the Scheme in accordance with applicable law, Marudhar, our Promoter Group entity, will merge in to NFSPL, our corporate Promoters, on account of which the shareholding of NFSPL in our Company will rise to the extent of the present shareholding of Marudhar in our Company. As on the date of this Red Herring Prospectus, Marudhar holds 1.96% of our shareholding while NFSPL holds

55.14% of our shareholding and post the approval of the Scheme, the resultant shareholding of NFSPL will aggregate 57.10% of our issued, subscribed and paid-up share capital. For details, see, “**Summary of the Offer Document- Aggregate pre-Offer Shareholding of Promoters, Promoter Group and Selling Shareholders**” on page 18. However, shareholding of our Promoter and Promoter Group, will remain unchanged, as they will collectively continue to hold an equal number of Equity Shares in aggregate. Pursuant to an application filed by NFSPL, Marudhar and M.M. Group Holdings Private Limited, the NCLT passed a corrigendum order dated September 21, 2021 dispensing the requirement of holding meetings of the shareholders of NFSPL and M.M. Group Holdings Private Limited and meetings of the unsecured creditors and secured creditors of NFSPL, Marudhar and M.M. Group Holdings Private Limited. Further, the meeting of the shareholders of Marudhar has been scheduled to be held on December 15, 2021 subject to completion of the conditions prescribed in the said order. We cannot estimate the time involved in obtaining the approval of the Scheme from the NCLT and in consequently transferring the Equity Shares in accordance with the Scheme and accordingly we cannot assure you that such transfer will be completed prior to the proposed listing of our Equity Shares on the Stock Exchanges. Further, we cannot assure that the Scheme will be approved within a reasonable time, or at all and the Company does not have any control over the order to be passed by the NCLT in this regard.

**27. *Our efforts in obtaining and protecting our patents may be costly and unsuccessful, which may have an adverse effect on our business and results of operations.***

Patents over our developed products provide exclusivity in the market in which we operate, which is important for the successful marketing and sale of our products. We have sought, and continue to seek patents covering a variety of our products in India and globally. As on June 30, 2021, we have been granted 8 patents in India and overseas including USA, South Africa and Brazil in relation to our inventions.

The details of our patents registered in India and overseas as on the date of this Red Herring Prospectus are set out below.

Particulars	Patent registration number	Entity	Country of registration	Validity
Improved screen panel	352307	Company	India	May 20, 2030
Mosaic liner for chute/ Hopper lining	356469	Company	India	July 25, 2033
Improved screen panel and fixing arrangements therefor	231453	Company	India	March 27, 2022
Improved screen panel	9149841	Company	United States	May 20, 2030
Improved screen panel	BR 112012029 345-1	Company	Brazil	March 20, 2031
Improved screen panel	2012/08604	Company	South Africa	November 14, 2032
Ceramic chute liner	2015/07279	Company	South Africa	July 22, 2033
Mosaic liner for chute/ Hopper lining	2016/00190	Company	South Africa	September 8, 2033

Further, we have submitted 4 applications for registration of certain of our inventions in India, which are pending before the Office of the Controller General of Patents, Designs and Trade Marks. Third parties may challenge, seek to invalidate or circumvent our patents and/or patent applications. Our applications may be opposed, or our competitors may have filed similar patent applications or hold patents relating to products or processes that compete with those that we are developing or are seeking to protect. We cannot assure you that we will be granted the patents that we apply for, in a timely manner, or at all.

Although we may defend our patent rights, there can be no assurance that our defence will be successful. We have initiated certain proceedings, which are currently pending, alleging infringement of our patents by the respective parties who are manufacturing, using and supplying a product which was identical to the patented invention of our Company and we cannot assure you that these proceedings will be determined in our favour. For instance, we have initiated infringement proceedings against certain third parties, requesting the relevant judicial forums to provide us relief against infringement of our patents pertaining to screen panel and fixing. Such existing patent litigation and any other challenges to our Company’s patents in the future may be costly and unpredictable. For details, see “**Outstanding Litigation and other Material Developments - Outstanding material civil proceedings involving our Company**” on page 355. If one or more of our important patented products lose patent protection in profitable markets due to any reason including expiry of their term of registration, sales of those products

may decline if alternative products become available, and this may have an adverse effect on our business and results of operations.

**28. *We are subject to risks associated with expansion into new geographic markets globally. Any inability to expand into new geographic markets may adversely affect our growth and future prospects.***

Any geographic expansion subjects us to various challenges, including those relating to our lack of familiarity with consumer preferences, regulations and economic conditions of new markets. Language barriers, cultural differences, difficulties in staffing and managing such operations, coupled with a possible lack of brand recognition locally may also affect our ability to expand into newer geographic markets. The major markets where we are currently expanding our operations include North America, South America, Australia and South Africa.

Further, depending on the product we market in such new territories, we may also face significant competition from other players who may already be established in such markets and may have a significant market share, or from a well-established player. We may not be able to compete effectively with such players if we are unable to offer competitive products at better price points which appeal to consumers in such markets. Some of our competitors in such geographies may also have certain competitive advantages, including access to local knowledge and resources, which may restrict our ability to increase our market share. By expanding into new geographical markets, we may be exposed to significant liability, including due to increased compliance costs on account of local laws and regulations, and may not receive the intended return on our investments. Any inability to enter into new geographic markets profitably, or at all, could adversely affect our growth, future prospects, financial condition and results of operation.

**29. *We do not have long-term agreements with a majority of our customers. Any changes or cancellations to our orders or our inability to forecast demand for our products may adversely affect our business, results of operations and financial condition.***

We do not have firm commitments or long-term supply agreements with a majority of our customers and instead rely on purchase orders. Many of the purchase orders we receive from our customers specify a price per unit and delivery schedule, and the quantities to be delivered are determined closer to the date of delivery. However, such orders may be amended or cancelled prior to finalisation, and should such an amendment or cancellation take place, it may adversely impact our production schedules. As of June 30, 2021, our order book for our products was ₹3,161.36 million. Our order book typically represents business that is considered by us to be 'firm', although cancellations or unanticipated variations or scope or schedule adjustments may occur due to unforeseen circumstances. The occurrence of any such events may lead to in the cancellation of orders or the deferment of revenue, which may adversely affect our business, results of operations and financial condition.

Additionally, as we do not bind a majority of our customers to any long-term agreements specifying a certain volume of business required to be transacted between us, our customers may terminate their relationship with us, with or without cause, with little or no advance notice and without compensation. Consequently, there is no commitment on the part of the customer to continue to place new purchase orders with us and as a result, our sales from period to period may fluctuate significantly.

Further, absence of any contractual exclusivity in relation to our business arrangements with our customers poses a threat on our ability to be able to continue to supply our products to these customers in the future. If we overestimate demand, we may incur additional raw materials costs and manufacture a higher of number of products than required. Similarly, if we underestimate demand, we may not procure sufficient raw material in a timely manner, which could impact our production and delivery schedules. Any significant inaccuracy in demand forecasting may adversely impact our ability to deliver products to customers in a timely manner, or at a competitive cost, which may adversely affect our business, results of operations and financial condition.

**30. *We are subject to strict quality requirements and any failure by us to comply with quality standards or product defect may lead to the cancellation of existing and future orders, reputational risks and liability claims.***

We face an inherent business risk of exposure to product defects and failure to comply with the high quality standards of our customers. While we test for quality at our quality labs at each manufacturing



facility, we cannot assure you that all products would meet our quality standards or the high quality standards imposed by our customers. Additionally, because of the longer useful life of some our products, it is possible that latent defects might not appear for several years. Further, any stoppage of work for a mining company results in a significant loss of revenue for such company even in short periods of stoppages. Accordingly, we may be required to immediately replace products which do not meet the required quality standards at no cost to our customers or we may lose our customers to our competitors.

We also face potential liability claims in the event that the use of any of our products results in personal injury or property damage due to equipment failure, work accidents, fire or explosion, if our products are defective. In the event that any of our products are defective, we may be, amongst others, responsible for damages relating to any defective products, required to replace, recall or redesign such products, or incur significant costs to defend any such claims, each of which may have an adverse effect on our reputation, future orders, business and results of operations.

During Fiscals 2015 to 2017, our customers experienced defects in certain products manufactured at our manufacturing facility in Dahej, Gujarat. During this period, the defective products constituted 2.07%, 1.70% and 0.86% of our total products manufactured at the manufacturing unit in Dahej, Gujarat for Fiscals 2015, 2016 and 2017, respectively. In response, we firstly replaced the defective products free of cost to address the issues that were being faced by our customers. Secondly, in order to prevent any such product quality related issues in the future, we focussed on improving the manufacturing processes at our manufacturing facility in Dahej, Gujarat by, amongst others, implementing additional control procedures and quality standards, increasing the monitoring and audit process and conducting routine training session for employees. We incurred significant replacement costs as well as costs for implementing the preventive measures undertaken by us, suffered loss of customer confidence and few customers, which adversely affected our order book and revenues. We incurred an expenditure of ₹86.45 million and ₹20.04 million in FY 2016 and FY 2017 respectively, in replacing the defective products. We cannot assure you that such product quality related issues will not occur in the future and we can continue to comply with the quality requirement standards of our customers and result in a liability claims against us.

While we maintain insurance coverage, including a product liability insurance covering product recall expenses, product guarantee and financial losses, in keeping with what we believe to be the industry standard, we cannot assure you that we are sufficiently insured against punitive damage awards. In the event that any significant product liability, performance improvement or replacement claims are brought against us, which are not entirely covered by insurance, it may adversely affect our business, financial condition, results of operations and prospects. Further, despite insurance coverage, in the event of any future accident or liability involving our products, our customers may delay or withhold payments to us and/or seek to enforce liability claims against us, and which in turn may, to that extent, diminish our reputation, making it difficult for us to operate our business and compete effectively, which may adversely affect our business, financial condition and results of operations.

- 31. *We have undertaken a joint venture and strategic acquisitions in the past and seek to continue our inorganic growth strategy in the future. Any such joint ventures, strategic acquisitions or investments may be difficult to integrate and manage and may expose us to uncertainties and risks, any of which could adversely affect our prospects, business, financial conditions and result of operations.***

We may continue to undertake joint ventures and strategic acquisitions as well as undertake strategic investments, alliances, partnerships or initiatives, both in India and overseas, to expand our operations, such as through our acquisitions of Beruc Equipment (now Tega Industries Africa Pty Ltd), South Africa in 2006 and Acotec S.A (now Tega Industries Chile SpA), Chile in 2011 and Losugen Pty Ltd, Australia in in 2010. For details, see “*History and Other Corporate Matters - Details regarding material acquisitions or divestments of business/undertakings, mergers, amalgamation, revaluation of assets, etc. in the last 10 years*” on page 172.

These arrangements may require us to incur or assume new debt, expose us to future funding obligations or integration risks and we cannot assure you that such acquisitions, joint ventures or other such arrangements will contribute to our profitability. There are no guarantees that we will be able to successfully integrate any companies or assets we acquire, or that we will realize the strategic and/or operational benefits that we expect. Moreover, we may expend significant management attention trying to do so, but may not see the desired results. In addition, there can be no assurance that we will be able to consummate our expansions, acquisitions or alliances in the future on terms acceptable to us, or at all.

We have in the past relied on inorganic growth as a part of our growth strategy. We may seek to identify and complete acquisitions and investments that meet our strategic and financial return criteria. However, there can be no assurance that going forward, we will be able to identify suitable acquisition or investment targets and if such targets are identified, we may face several risks, including the following:

- difficulties in arranging adequate financing (whether debt or equity or a combination thereof) on commercially reasonable terms, to complete our planned investments or acquisitions in the budgeted time;
- difficulties or delays in obtaining lender consents required under our financing agreements, prior to undertaking any planned investments or acquisitions;
- potential assumption of unanticipated liabilities and contingencies of the target entity, including claims from current or former creditors, customers, suppliers, employees and other third parties;
- potential adverse short-term effects on operating results through increased costs or otherwise;
- difficulties or expenses related to retaining key employees and customers critical for the target entity; and
- unforeseen difficulties in extending disclosure and other internal controls and procedures over financial and other reporting and in performing the required assessment and remediation at the newly acquired business.

Further, in the future if such arrangements are severed or disrupted, it would impair our investments and impact our business, our failure to derive anticipated synergies from such arrangements or integrate acquisitions into our existing business and operations or identify suitable targets and successfully acquire or invest in them may adversely affect our prospects, business, financial condition and results of operations.

**32. *Our Joint Venture may not perform its obligations satisfactorily and its interests may differ from ours, which could have an adverse effect on our business and results of operations.***

We currently have a joint venture in India with Hosch (G.B.) Limited, England, which is engaged in precision conveyor belt cleaning and caters to various industries and we may continue to pursue strategic alliances in the future. For details, see “*Our Business*” and “*History and Certain Corporate Matters-Joint Venture*” on pages 141 and 179, respectively. The share of restated net profit of Joint Venture accounted for using the equity method included in our restated profit before tax is 0.34%, 0.31%, 0.26% and 0.28% of our total income in the three months period ended June 30, 2021 and Fiscals 2021, 2020 and 2019, respectively.

The success of our business collaborations depends significantly on the satisfactory performance by our joint venture partner and fulfilment of its obligations. If our joint venture partners fail to perform these obligations satisfactorily, the Joint Venture may be unable to perform adequately or deliver its contracted products. In such a circumstance, we may be required to make additional investments or become liable for our partner’s obligations to ensure the adequate performance and delivery of the contracted products, as we are subject to joint and several liabilities as a member of the Joint Venture. Such additional obligations could result in reduced profits or, in some cases, significant losses for us. If the interests of our joint venture partner conflict with our interests or it is otherwise unwilling to fulfil its’ obligations under our contractual arrangement, our Joint Venture may act in a manner that is contrary to our interests. Any of the foregoing could have an adverse effect on our business, results of operations, financial condition, and reputation.

**33. *We may not be successful in managing our growth or implementing our strategies, such as increasing our market penetration and share of customer wallets or growing our product and service offerings, which may materially adversely affect our business, results of operations and future prospects.***

The success of our business depends greatly on our ability to effectively manage our business and implement our strategies. For details, see “*Our Business*” beginning on page 141. Even if we have successfully executed our business strategies in the past, there can be no assurance that we will be able to execute our strategies on time and within the estimated budget, or that we will achieve an adequate

return on our investment or maintain current or prospective growth rates. Even if we are able to implement some or all of the initiatives of our business strategy successfully, our operating results may not improve to the extent we anticipate, or at all.

Any significant failure to accurately assess new and existing markets, attract new customers and grow our existing customers' wallet share, innovate existing products and develop new products, obtain sufficient financing for our expected capital expenditures, control our input costs, effectively expand, train and manage our employees, maintain sufficient operational and financial controls or make additional capital investments to take advantage of anticipated market conditions, may result in our inability to achieve growth in revenues and profits or maintain such rate of growth in the future. Further, if we fail to make a proper assessment of the operational risks, credit risks and execution risks associated with our operations, we may not be able to effectively implement our growth strategies in a profitable manner, or at all.

Moreover, if we experience extended periods of very rapid growth, we may not be able to manage our growth effectively with available resources. As we scale up and diversify our operations, we may additionally not be able to execute our operations efficiently, which may result in delays, increased costs and lower quality products. If we are unable to execute our strategies effectively, and in a timely and successful manner, our business, financial condition and profitability will be adversely affected.

**34. *Certain of our Subsidiaries have incurred losses in the past and may incur losses in the future which may have an adverse effect on our reputation, financial condition and results of operations.***

Certain of our Subsidiaries have incurred losses in the preceding three Fiscals. The following table sets forth information on the Subsidiaries that have incurred losses as per the restated financial information of the respective subsidiaries, converted in INR, in the three months period ended June 30, 2021 and preceding three Fiscals:

*(in ₹ million)*

Particulars	For three months period ended June 30, 2021			For year ended March 31, 2021			For year ended March 31, 2020			For year ended March 31, 2019		
	Revenue from Operations	Profit / (Loss)	% of Total Revenue	Revenue from Operations	Profit/ (Loss)	% of Total Revenue	Revenue from Operations	Profit/ (Loss)	% of Total Revenue	Revenue from Operations	Profit/ (Loss)	% of Total Revenue
Tega Industries Australia Pty Ltd	113.15	7.29	6.44	439.64	0.26	0.06	393.21	(50.69)	(12.89)	514.30	(12.33)	(2.40)
Tega Do Brasil Servicos Technicos Ltda	-	4.08	N/A	5.37	0.23	4.28	1.57	(5.28)	(336.31)	10.37	1.16	11.19
Tega Investment Ltd	-	(2.15)	N/A	0.00	73.39	N/A	0.00	(4.47)	N/A	0.00	(8.17)	N/A
Tega Holding Pty Ltd	-	(5.80)	N/A	0.00	(22.77)	N/A	0.00	9.18	N/A	0.00	37.04	N/A
Tega Industries Inc	80.76	0.40	0.50	529.62	55.56	10.49	318.52	3.87	1.21	328.79	(1.82)	(0.55)
Tega Industries Canada Inc	219.06	25.79	11.77	513.08	30.39	5.92	504.45	11.33	2.25	248.65	(48.17)	(19.37)
Tega Investment SA Pty Ltd	-	0.75	N/A	0.00	(0.11)	N/A	0.00	0.03	N/A	0.00	(0.19)	N/A
Tega Industries Africa Pty Ltd	166.42	0.29	0.17	1,003.35	125.17	12.48	717.08	6.41	0.89	763.34	(2.65)	(0.35)
Tega Holdings Pte Ltd	119.73	(95.82)	(80.03)	508.82	1,670.20	328.25	1,162.64	129.48	11.14	1,072.12	(54.45)	(5.08)
Tega Industries Chile SpA*	294.43	(30.19)	(10.25)	1,827.37	227.01	12.42	1,401.26	148.80	10.62	1,018.54	(314.60)	(30.89)

\* Includes consolidated financial information related to Tega Industries Chile SpA and its subsidiaries, i.e., Edoctum S.A. and Edoctum Peru S.A.

There can be no assurance that our Subsidiaries will not incur losses in the future which may have an adverse effect on our business, results of operations and financial condition.

**35. *Our business is capital intensive. We may not be able to obtain sufficient capital on terms favourable to us, or at all, which may hamper our business and our growth.***

Our business is capital intensive as we have acquired, expanded and upgraded our manufacturing facilities. For the three months period ended June 30, 2021 and Fiscals 2021, 2020 and 2019, the additions to our property, plant and equipment were ₹64.86 million, ₹243.29 million, ₹237.91 million and ₹244.30 million, respectively, which represented 3.74%, 3.02%, 3.47% and 3.85% of our revenue from operations for the respective periods. Also, provide working capital requirement and our loan base for the same and mention about the rate of interest The actual amount and timing of our future capital requirements may differ from estimates as a result of, among other factors, unforeseen delays or cost overruns, unanticipated expenses, regulatory changes, economic conditions, engineering design changes, weather related delays, technological changes and additional market developments and new opportunities in the global mineral beneficiation, mining and bulk solids handling industry.

Our sources of additional capital, where required to meet our capital expenditure plans, may include the incurrence of debt or the issue of equity or debt securities or a combination of both. Further, our budgeted resources may prove insufficient to meet our requirements, draining our internal accruals or requiring us to raise additional capital. If we are required to raise additional funds through the incurrence of debt, our interest and debt repayment obligations will increase, and could have a significant effect on our profitability and cash flows and we may be subject to additional covenants, which could limit our ability to access cash flows from operations. If we are unable to successfully utilise the facilities for which we have raised additional funds, it will have adverse effect on our business. Any issuance of equity, on the other hand, would result in a dilution of your shareholding.

In many cases, a significant amount of our working capital is required to finance the purchase of materials and the performance of manufacturing our products and other work before payment is received from customers. Our working capital requirements may increase if the payment terms in our agreements include reduced advance payments or longer payment schedules. These factors may result, or have resulted, in increases in the amount of, our receivables, short-term borrowings and the cost of availing such working capital funding. Further, if a significant customer defaults on or delays payment on any order to which we have invested significant resources, it may affect our profitability and liquidity and decrease capital resources available to us for other uses, including our obligations under the working capital facilities granted to us by our lenders as well as our ability to fund payables to our suppliers, which may further result in reduced availability of raw materials and/or increased raw material costs. If we are unable to obtain adequate amount of working capital at such terms which are favourable to us and in a timely manner or at all may also have an adverse effect on our financial condition.

**36. *Any failure to compete effectively in the mineral beneficiation and mining industry could have a material adverse effect on our business, financial condition, results of operations and cash flows.***

Any failure to compete effectively in the mill liners industry could have a material adverse effect on our business, financial condition, results of operations and cash flows. We face competition in India and overseas in our business, which is based on many factors, including product quality and reliability, breadth of product range, product design and innovation, technology, manufacturing capabilities, scope and quality of service, price, product portfolio, business model and brand recognition. We compete with global competitors to retain our existing business as well as to acquire new business. For details, see *'Industry Overview- Global Mill Liner Industry'* on page 123. Some of our competitors may have certain advantages, including greater financial, technical and/ or marketing resources, which could enhance their ability to finance acquisitions, fund international growth, respond more quickly to technological changes and/ or operate in more diversified geographies and product portfolios. Further, the industry in which we operate presents significant entry barriers, including customer validation and approvals, expectation from customers for product innovation, high quality standards and stringent specifications. As a result, any change in the manufacturer by a customer may require customers to expend significant time and resources, resulting in the acquisition of customers becoming a long process. Any of these factors could have a material adverse effect on our business, financial condition, results of operations and cash flows.

In addition, we face increasing competition across our product portfolio. Some of our competitors may

be able to produce similar or equivalent products at lower costs than we can produce them. Further, manufacturers that do not currently compete with us could expand their product portfolios to include products that would compete directly with ours. Accordingly, we may not be able to compete effectively with our competitors, which may have an adverse effect on our business, financial condition, results of operations and cash flows.

**37. *Climate change and climate change related laws and regulations concerning the mining industry may adversely impact our operations and markets.***

Mining activities are energy-intensive, with power and fuel being significant inputs in the operations of our customers and there is growing recognition that energy consumption is a contributor to global warming, greenhouse effects and climate change. The Government of India and a number of governmental bodies (domestic and international) have introduced or are contemplating regulatory change in response to the potential impact of climate change. There is also current and emerging regulation, energy targets and initiatives relating to solar power and wind power that can affect energy prices. Such regulatory mechanisms may be either voluntary or legislated and may impact our operations directly or indirectly through customers. In the event that such regulations are enacted and are more aggressive than the sustainability measures that are currently being undertaken, our customers may experience significant increases in their costs of operations and in turn reduce their cash flow and/or revenue. Assessments of the potential impact of future climate change regulation are uncertain, given the wide scope of potential regulatory change in India and overseas. The potential physical impact of climate change on our operations and those of our customers are highly uncertain, and will be particular to the geographic circumstances. These effects may adversely impact the cost, production and financial performance of our operations.

Further, many of our products use raw materials which creates health, ecological and environmental risks through its lifecycle of production, use and disposal. Major technological and capital investments may be needed to keep up with requirements of managing such risks. Legislations may be imposed which require stringent waste and product management requirements which we may not be able to comply with across all our production and usage sites. We, our vendors and customers may be adversely impacted by penalties and fees mandated by various governments and inter-governmental bodies, thus affecting our operations, business and cash flows.

**38. *We depend on our key management team, as well as our mid-to-senior management personnel and our success also depends on certain of our individual Promoters. If we are unable to attract or retain such persons, our operations may be adversely affected.***

Our business and the implementation of our strategy is dependent upon our key executives, including our KMPs, who oversee our day-to-day operations, strategy and growth of our business. If one or more members of our key management team are unable or unwilling to continue in their present positions, such persons would be difficult to replace in a timely and cost-effective manner. We may need to increase compensation and other benefits in order to attract and retain personnel in the future and that may affect our costs and profitability.

In addition, our success in expanding our business will also depend, in part, on our ability to attract, retain and motivate mid-to-senior management personnel. We may need to increase compensation and other benefits in order to attract and retain personnel in the future and that may affect our costs and profitability. These risks could be heightened to the extent we invest in businesses or geographical regions in which we have limited experience. If we are not able to address these risks, our business, results of operations and financial condition could be materially adversely affected.

We are also highly dependent on our Promoters to manage our current operations and to meet future business challenges. In particular, we rely on the experience and industry relationships of certain of our individual Promoters. For details, see “*Our Business*” and “*Our Promoter and Promoter Group*” on pages 141 and 199, respectively. In particular, the active involvement of our Promoters in our operations, including through strategy, direction and customer relationships have been integral to our development and business. Should the involvement of such individual Promoters in our business reduce, or should our relationship with any of them deteriorate for any reason in the future, our business, financial condition, results of operations and prospects may be adversely affected.

39. ***Information relating to the installed capacity, actual production and capacity utilization of our manufacturing facilities included in this Red Herring Prospectus are based on various assumptions and estimates and future production and capacity may vary.***

Information relating to the installed capacity, actual production and capacity utilization of our manufacturing facilities included in this Red Herring Prospectus are based on various assumptions and estimates of our management that have been taken into account in the calculation of our installed capacity, actual production and capacity utilization. Actual production levels and future capacity utilization rates may vary significantly from the estimated production capacities of our manufacturing facilities and historical capacity utilization rates. In addition, capacity utilization is calculated differently in different countries, industries and for the different kinds of products we manufacture. Undue reliance should therefore not be placed on our historical installed capacity, actual production and capacity utilization for our existing manufacturing facilities included in this Red Herring Prospectus. See “*Business – Manufacturing Facilities*” on page 157.

40. ***Our present engineering capabilities and sustained growth depends on our ability to attract and retain persons with technical training and expertise, and any failure to attract and retain such persons may adversely affect our product quality, business and financial condition.***

Our ability to provide high quality complex products, customized designs and better service standards to our customers depends, in part, on our ability to retain and attract persons with technical expertise. Our global workforce comprised of 1,698 employees (905 permanent and 793 contractual), 1,704 employees (906 permanent and 798 contractual), 1,693 employees (885 permanent and 808 contractual) and 1,619 employees (885 permanent and 734 contractual) as of June 30, 2021, March 31, 2021, March 31, 2020 and March 31, 2019, respectively. Competition for such personnel is intense and the cost of retaining or replacing such personnel may affect our profitability. In addition, our strategies for growth have placed, and are expected to continue to place, increased demands on our management’s and employees’ skills and resources.

Our future performance would depend on the continued service of such persons with technical expertise and the loss of any skilled personnel and the inability to find an adequate replacement may impair our relationship with key customers which may adversely affect our business, financial condition, results of operations and prospects.

41. ***Failure to obtain or renew necessary regulatory approvals, licenses, permits in a timely manner, or at all, may adversely affect our business and financial condition.***

Our operations are subject to extensive government regulation and we are required to obtain and maintain a number of statutory and regulatory permits and approvals under central, state and local government rules in the geographies in which we operate, generally for carrying out our business and for our manufacturing facilities. For details of material approvals relating to our business and operations, see “*Government and Other Approvals*” on page 359.

A majority of these approvals are granted for a limited duration and require timely renewal. Some of these approvals have expired and we have either made or are in the process of making an application for obtaining the approval for its renewal. Further, while we have applied for some of these approvals, we cannot assure you that such approvals will be issued or granted to us in a timely manner, or at all. If we do not receive such approvals or are not able to renew the approvals in a timely manner, our business and operations may be adversely affected. We are also required to make payments pursuant to statutory requirements. There can be no assurance that delays will not occur in making such payments in the future and that the relevant authority will not initiate actions against us for such delays.

The approvals required by us are subject to numerous conditions and we cannot assure you that these would not be suspended or revoked in the event of non-compliance or alleged non-compliance with any terms or conditions thereof, or pursuant to any regulatory action. If there is any failure by us to comply with the applicable regulations or if the regulations governing our business are amended, we may incur increased costs, be subject to penalties, have our approvals and permits revoked or suffer a disruption in our operations, any of which could adversely affect our business. In addition, these registrations, approvals or licenses are liable to be cancelled or the manufacture or sale of products may be restricted. In case any of these registrations, approvals or licenses are cancelled, or its use is restricted, then it could adversely affect our results of operations or growth prospects.

42. ***There has been an instance in the past where there were certain discrepancies in relation to certain statutory filings and corporate records of our Company and we cannot assure you that such inadvertent discrepancies will not occur in the future.***

There has been a discrepancy in relation to the statutory filing and records required to be made with the RoC with respect to the appointment of one of our erstwhile Directors, Dhiraj Poddar. Dhiraj Poddar was appointed as a nominee director of Wagner Limited on our Board on May 11, 2011, in accordance with the Shareholders Agreement. However, the Form 32 filed in relation to his appointment inadvertently categorised him as a ‘Non-executive- Independent Director’. Pursuant to our Shareholders’ resolutions dated August 7, 2021 to clarify his position as a nominee director on our Board and our Company has filed a Form MGT-14 to rectify the records maintained by the Registrar of Companies. While our Company intends to rectify the Form-32/DIR-12 filing in this regard, we are currently coordinating with the office of the Registrar of Companies to initiate the process in this regard and cannot assure you that a rectified Form-32/DIR-12 will be filed in a timely manner, or whether the RoC may direct any other penalty or censure in this matter.

Further, our Director, Syed Yaver Imam, who was designated as an Executive Director for the period from July 19, 2005 to May 31, 2019 and is currently an Executive Director on our Board, has in the past been designated as a Non-executive director on our Board from June 1, 2019 to March 31, 2021. Our Board has redesignated him as an Executive Director with effect from April 1, 2021, in accordance with applicable law. Our Company has filed a Form DIR-12 for his change in designation.

43. ***We are subject to various laws and regulations in jurisdictions where we operate, including environmental and health and safety laws and regulations, which may subject us to increased compliance costs, which may in turn result in an adverse effect on our financial condition.***

In accordance with the locations of our manufacturing facilities, we are required to comply with Indian central, state and local laws, as well as the laws of the foreign jurisdictions where our manufacturing facilities are located specifically relating to the protection of the environment and occupational health and safety, including those governing the generation, handling and disposal of, or exposure to, environmental pollutants, discharge of waste or hazardous materials and controlling the emissions resulting from our manufacturing processes. For details of the regulations applicable to our manufacturing facilities in India, see “***Key Regulations and Policies in India***” beginning on page 167.

If we fail to comply with such laws and regulations, we could be subject to significant fines, penalties, costs, liabilities or restrictions on operations. Environmental and occupational health and safety laws and regulations, and the interpretation and enforcement thereof, are subject to change and have become stricter over time, in India and internationally. We are also subject to laws requiring the clean-up of contaminated property. Under such laws, we could be held liable for costs and damages relating to contamination at our facilities and at third party sites to which these facilities send waste material.

While we are not aware of any outstanding material claims or obligations, we may incur substantial costs, including clean up or remediation costs, fines and civil or criminal sanctions, and third-party property damage or personal injury claims, as a result of violations of or liabilities under environmental or health and safety laws or non-compliance with approvals obtained by us in relation to our manufacturing facilities, any of which may adversely affect our business, financial condition and results of operations. Previously, the Gujarat Pollution Control Board had raised concerns regarding the discharge of effluents from our manufacturing facility located at Dahej, Gujarat and consequently suspended the power supply to our facility. While these concerns were later resolved in our favour, to minimize future risk and disruptions of our operations, we commissioned an effluent treatment plant, incurring additional costs.

In addition, our customers are mining companies, whose operations are geographically diverse and subject to or affected by stringent regulations in the jurisdictions where they operate, such as applicable environmental and health and safety laws and regulations. As a result of changes in regulations and laws relating to their activities, our customers’ operations may be disrupted or curtailed. The cost of compliance with such laws and regulations may also induce certain customers to limit certain operations or discourage them from developing new opportunities. As a result of these factors, demand for our products may be negatively affected by regulations adversely impacting the industries and geographies in which our key customers operate.

**44. We may become subject to more stringent labour laws or other industry standards, which may increase our compliance costs and adversely affect our profitability, business, results of operations and financial condition.**

We are subject to a number of stringent labour laws, both in India and the foreign jurisdictions where our manufacturing facilities or operations are located. India has stringent labour legislation that protects the interests of workers, including legislation that sets forth detailed procedures for dispute resolution and employee removal, establishment of unions and legislation that imposes financial obligations on employers upon retrenchment and periodic revisions to minimum wage. For details of the labour laws applicable to our Company in India, see '**Key Regulations and Policies**' on page 167 of this Red Herring Prospectus. Several labour laws in relation to establishment of unions, pension provisions, employment benefits, termination of employment are applicable, particularly to our operations in Chile, Australia and South Africa where our manufacturing facilities are located and we are required to comply with these legislations, obtain relevant approvals/ registrations and make periodical filings before the relevant authorities in these jurisdictions. If we or our Subsidiaries, as applicable, are unable to comply with such labour laws or maintain necessary approvals required for our continued operations, this may have consequences, such as operations that may be limited or suspended to that extent, which may have an adverse impact on our business and results of operations. Recently, the Government of India enacted the Code on Wages, 2019, the Occupational Safety, Health and Working Conditions Code, 2020 and the Industrial Relations Code, 2020, all of which will be brought into force on a date to be notified by the Central Government. For details, see "**Key Regulations and Policies in India**" beginning on page 167. These codes propose to subsume several existing laws and regulations in India and we cannot assure you that these codes will not impose more stringent or additional compliance requirements on us, which may increase our compliance costs and adversely affect our profitability. Further, we may be subject to changing judicial interpretation of the relevant statutes, which may adversely affect our cash flows and profitability. For instance, the Supreme Court of India in a recent judgment has upheld the circular dated March 20, 2019 issued by the Employees' Provident Fund Organisation, which excludes certain allowances from the definition of 'basic wages' of the relevant employees for the purposes of determining contribution to provident fund under the EPF Act and while we typically assess the impact of such developments on our operations and expenses, we cannot assure that we will not be adversely affected by such developments in the future. For details, see '**Restated Consolidated Financial Information**' on page 207.

We are also subject to international, federal, state and local laws and regulations, in all jurisdictions where we have operations, governing our relationships with our employees, including those relating to minimum wage, overtime, working conditions, hiring and firing, non-discrimination, work permits and employee benefits. If labour laws become more stringent or are more strictly enforced, it may become difficult for us to maintain flexible human resource policies, discharge employees or downsize, any of which could have an adverse effect on our business, results of operations and financial condition.

**45. We may not meet our obligations, including financial and other covenants under our debt financing arrangements, which could adversely affect our cash flows, business, results of operations and financial condition.**

As on September 30, 2021, our total secured borrowings from banks amounted to ₹1,739.41 million (secured borrowings are not inclusive of non-fund based working capital facilities), comprising 97.57% of our total debt. Our unsecured borrowings from banks amounted to ₹43.35 million, comprising 2.43% of our total debt, as on September 30, 2021. Our debt equity ratio was 0.29, 0.31, 0.53 and 0.53 as of June 30, 2021, March 31, 2021, March 31, 2020 and March 31, 2019, respectively. For details, see "**Financial Indebtedness**" and "**Restated Consolidated Financial Information – Annexure V - Note 4I**" on pages 314 and 262, respectively. Certain of our borrowing are foreign currency denominated, mainly in USD. For risks in this regard, see "**-Depreciation of the Indian Rupee and exchange rate fluctuations in currencies in which we do business or have outstanding borrowings may materially and adversely impact our business, financial condition and results of operations.**" above.

Our leverage has several important consequences, including the following:

- A portion of our cash flow from operations will be used towards repayment of debt, which will reduce the availability of cash to fund working capital requirements, capital expenditures, acquisitions and other general corporate purposes.



- As on September 30, 2021, we had total long term secured borrowings of ₹945.87 million. These borrowings are secured, *inter alia*, through a charge by way of hypothecation on our present and future current assets and fixed assets as well as through mortgage on our land and building in favour of the lenders. For instance, as on March 31, 2021, all our assets in India are hypothecated or mortgaged, in favour of our lenders or security trustee, as applicable. Vehicle loans is secured by hypothecation of vehicle purchased. This may constrain our ability to raise incremental financing in the future, at commercially reasonable terms. While there have not been any instances in the past of enforcement of security interests owing to an event of default in relation to any properties mortgaged by us in favour of our lenders under any of our financing agreements, which have restricted our ability to operate our business at such locations, in the event of enforcement of an event of default in connection with such secured borrowings (which is not waived or cured) in the future, our ability to continue to operate our business at such locations may be restricted.
- Fluctuations in interest rates may affect our cost of borrowing, as all or a substantial part of our borrowings is at floating rates of interest. For details, see “-*We are subject to risks arising from interest rate fluctuations, which could adversely affect our results of operations planned expenditures and cash flows.*” below.

In particular, our financing agreements require us to maintain certain financial ratios including debt-equity ratio, and to obtain the consent of, or to intimate, our lenders for certain actions including:

- effecting any change in the ownership or control of our Company;
- effecting any change in the capital structure of our Company or any amendments to our Memorandum of Association or Articles of Association;
- effecting changes in the shareholding pattern of the Company, including shareholding of the promoters;
- entering into any schemes of mergers, amalgamations, compromise or reconstruction, acquisition;
- expansion of our business by way of capex expenditure, acquisition, investment or and other arrangements;
- undertaking any guarantee obligation on behalf of any other person;
- declaring and paying dividend in the event our Company defaults or delays in debt repayment of any of the lenders or upon the occurrence of any event of default;
- utilization of funds for any other purpose other than for which approval has been granted or agreed to be granted;
- approaching capital market for mobilizing additional resources either in the form of debt or equity;
- changing the general nature of the business of our Company; and
- effecting any change in management structure or composition of our Company.

Our Company has applied to its lenders and received all consents in relation to the Offer. Our failure to comply with financial or restrictive covenants or periodic reporting requirements or to obtain our lenders’ consent to take restricted actions in a timely manner or at all may result in the declaration of an event of default by one or more of our lenders, which may accelerate repayment of the relevant loans or increase applicable interest rates or cause the termination of our credit facilities or lead to the exercise of rights to convert the outstanding amounts into Equity Shares, or trigger the invocation of security under our financing arrangements or cross-defaults under certain of our other financing agreements.

An event of default may also affect our ability to raise additional funds or renew maturing borrowings to finance our existing operations and pursue our growth initiatives. The termination of, or declaration or

enforcement of default under, any financing agreement (if not waived or cured) may have an adverse effect on our cash flow, business, financial condition, results of operations and prospects.

46. ***Any failure to protect our intellectual property rights could adversely affect our competitive position, business, financial condition and results of operation. Further, if we inadvertently infringe on the intellectual property rights of others, our business and results of operations may be adversely affected.***

We believe that our intellectual property rights, which are a combination of patents and trademarks are vital to our competitiveness and success and for us to attract and retain our clients and business partners.

Our Company has registered our name and/or logo,  "tego" in 12 foreign jurisdictions including, the European Union, Canada, South Africa, Chile, and Australia with the relevant trademark registration authorities in such jurisdictions. In India, as on date of this Red Herring Prospectus, our Company and Losugen have registered 98 trademarks with the Registrar of Trademarks under the Trademarks Act. Further, our Company has been granted 8 patents in India under the Patents Act, 1970 and in certain foreign jurisdictions including USA, South Africa and Brazil under their respective legislations. For details of our intellectual property, see "***Business – Intellectual Property***" on page 165. We cannot guarantee when our existing trademarks and patents expire, we will be able to renew them in a timely manner, or at all.

We may not be able to safeguard our intellectual property from infringement or passing off, both domestically and internationally, since we have operations in several countries and may not be able to respond to infringement or passing off activity occurring without our knowledge in a timely manner, or at all. Any improper use or infringement by any party may damage our business prospects, reputation and goodwill and reduce our revenue. The competitive advantage that we derive from our intellectual property may also be diminished or eliminated. Further, enforcement of any intellectual property rights could be time consuming and costly and a favourable outcome cannot be guaranteed. For risks in relation to our patents, see, "***Our efforts in obtaining and protecting our patents may be costly and unsuccessful, which may have an adverse effect on our business and results of operations.***" above.

We also rely on technical knowledge, product information, industry data, manufacturing expertise and market "knowhow" that cannot be registered and is not subject to any confidentiality or nondisclosure clauses or agreements. If such know-how is leaked to third parties, this could erode our competitive advantage. Our trade secrets may become known or independently developed by our competitors, and in such cases, we may no longer enjoy the exclusive use of some of our innovations or maintain the confidentiality of information relating to our products. Additionally, we may face claims for breach of intellectual property by third parties. If we are subject to any adverse rulings or decisions, our manufacture and sale of such products could be significantly restricted or prohibited and we may be required to pay substantial damages or on-going licensing fees. If we are unable to protect our intellectual property and technical knowledge against third party infringement or breaches of confidentiality, or are found to infringe on the intellectual property rights of others, it could have a material adverse effect on our business, results of operations and financial condition.

47. ***One of our manufacturing facilities is operated on industrial land allotted to us by industrial development corporation of West Bengal. Failure to comply with the conditions of use of such land could result in an adverse impact on our business and financial condition.***

Our manufacturing facility located at Kalyani, West Bengal is operated on industrial land allotted to us by the West Bengal Industrial Infrastructure Development Corporation. Under the terms of the lease agreement dated March 24, 1977, we have been granted a lease for a period of 99 years subject to compliance with certain ongoing conditions. Further, according to the various statutory rules under which the development corporation functions, it retains the power to cancel allotment of land in the event of breach of any rules of allotment. Cancellation of the land allotted by way of lease to us could have an impact on our financial condition which could adversely impact our results of operations and financial condition.

48. ***There are several restrictions on SEZs and underlying SEZ land in India, which may adversely affect our facility located in Dahej, Gujarat.***

Our facility located in Dahej, Gujarat is situated in a special economic zone ("SEZs") and the lease for this premise, therefore, restricts our ability to use the location to manufacture products for domestic sales.

(i.e., other than for exports) or to undertake any new line of business. Under the prevailing law governing SEZs in India, the land area in an SEZ may be demarcated into a processing area for setting up units for manufacture of products or provision of services, or an area exclusively for trading or warehousing purposes, or a non-processing area for other activities. The lease period for space in the processing area or the free trade and warehousing zone within an SEZ has to be for a minimum period of five years. Moreover, the developer cannot remove goods from the SEZ to the domestic tariff area (“DTA”) without permission from the relevant authority and, where applicable, certain duties are to be paid for clearance of goods in DTA. There are also certain restrictions on transfer of SEZ units, including the requirement to obtain the approval of the relevant authority for any proposed sale or transfer of an SEZ unit.

Further, the approvals received by us to develop, operate and maintain the SEZs are subject to us fulfilling certain conditions, including compliance with environmental safety standards, applicable standards relating to planning, sewage disposal, pollution control, labour laws and execution of certain guarantees. In the event we are unable to comply with the restrictions under the laws governing SEZs in India, our rights to use our units demarcated as SEZs may be suspended or withdrawn and the guarantees provided by us may be invoked against us as a penalty, which may in turn adversely affect our business, financial condition, results of operations and prospects.

In the event that regulatory authorities allege non-compliance of the Special Economic Zones Rules, 2006 and subject us to regulatory action for any reason in the future, we may be subject to consequences including penalties or seizure of land. Any such action or any changes to the SEZ regime may adversely affect our business, financial condition, results of operations and prospects.

**49. *We use contract labour at our manufacturing facilities and for carrying out certain of our ancillary operations and any failure to meet our obligations in relation to such contract labour could have an adverse effect on our results of operations and financial condition.***

In order to retain flexibility and control costs, our Company engages contract labour for our manufacturing facilities and certain other operations such as administration and sales. As on June 30, 2021, we engaged 793 contractual workforce. If we are unable to obtain the services of skilled and unskilled workmen at reasonable rates it will have an adverse effect on our business and results of operations. In addition, our manufacturing process is dependent on a technology-driven production system and any inability of the contract labourers to familiarize themselves with such technology could adversely affect our business, financial condition, result of operations and cash flows.

Although our Company does not engage these labourers directly, we may be held responsible for any wage payments to be made to such labourers in the event of default by such independent contractors. Any requirement to fund their wage requirements may have an adverse impact on our results of operations and financial condition. In addition, under the Contract Labour (Regulation and Abolition) Act, 1970, as amended, we may be required to absorb a number of such contract labourers as permanent employees. Thus, any such order from a regulatory body or court may have an adverse effect on our business, results of operations and financial condition.

**50. *Our operations at our manufacturing facilities are labour intensive and certain of our employees are affiliated to trade unions. We may be adversely affected by work stoppages, strikes or other types of conflicts with our employees in the future which may adversely impact our business and financial condition.***

Our manufacturing activities are labour intensive, require our management to undertake significant labour interface, and expose us to the risk of industrial action. Employees at our manufacturing facilities at Dahej, Gujarat, Chile, South Africa and Australia are affiliated with labour unions and have submitted their respective charter of demands with us and we have entered into a memorandum of settlement with the employees at both our manufacturing facilities at Samali and Kalyani, West Bengal. Employees at our manufacturing facility at Dahej, Gujarat are affiliated with the Federation of Labour, Bharuch since May, 2019 and established a second labour union in August, 2020 which has submitted a charter of demands with us. We contested the registration of the second labour union before the Assistant Commissioner of Labour, Bharuch on the grounds that both unions have the same members and accordingly cannot submit two separate charters of demands to our Company. The matter was referred to the Labour Court, Bharuch and was adjudicated in our favour. We cannot assure you that we will not be subject to such further demands and proceedings due to the actions of the labour unions established by our employees at all or any of our manufacturing facilities. Thus, it may be difficult for us to maintain

flexible labour policies, and we may face the threat of labour unrest, work stoppages and diversion of our management's attention due to union intervention.

Our operation may be affected by work stoppages, strikes or other types of conflicts with our employees. Further, we cannot ensure that our employees will not unionize in the future. Any such event, at our current facilities or at any new facilities that we may commission or acquire in the future, may adversely affect our ability to operate our business and serve our customers and impair our relationships with key customers and suppliers, which may adversely impact our business and financial condition.

**51. *Failure or disruption of our IT and/or ERP systems, or cybercrimes or similar disruptions, may adversely affect our business, financial condition, results of operations and prospects.***

We have implemented various information technology (“IT”) and/or enterprise resource planning (“ERP”) solutions to cover key areas of our operations. Further, we are dependent on technology in relation to customer order management and dispatches, production planning and reporting, manufacturing processes on the shop floor, financial accounting and scheduling raw material purchase and shipments. We rely on our IT infrastructure to provide us with connectivity and data backup across our locations and functions. While the ERP solutions that we have implemented have enabled us to improve our working capital cycles, we can provide no assurance that we will be able to do so in the future.

We have taken measures to deploy adequate IT disaster management systems including data backup and retrieval mechanisms, in all our facilities. However, any failure or disruption in the operation of these systems or the loss of data due to such failure or disruption (including due to human error or sabotage) may affect our ability to plan, track, record and analyze work in progress and sales, process financial information, manage our creditors, debtors and hedging positions, or otherwise conduct our normal business operations, which may increase our costs and otherwise adversely affect our business, financial condition, results of operations and prospects.

In addition, our systems and proprietary data stored electronically may be vulnerable to ransomware attacks, computer viruses, cybercrime, computer hacking and similar disruptions from unauthorized tampering. If such unauthorized use of our systems or those of our customers were to occur, data related to our customers, products, product development pipeline, payment systems and other information could be compromised.

**52. *Our growth depends upon our reputation and market perception and any failure to maintain, protect and enhance our reputation may have an adverse effect on our sales, profitability and the implementation of our growth strategy.***

We believe that our reputation and market perception are among our important assets. Any adverse change in the quality of products rendered by us including due to reasons beyond our control, or allegations of defects, even when false, at any of our manufacturing facilities could result in complaints from our customers and tarnish our reputation. For details, see “-*We are subject to strict quality requirements and any failure by us to comply with quality standards or product defect may lead to the cancellation of existing and future orders, reputational risks and liability claims.*” above.

Over time, our range of products such as DynaPrime, DynaSteel, Rapido have established a reputation amongst our customers and consequently a majority of our new customers and mill sites are those that have been referred to us by our existing customers by way of word of mouth appreciation. We believe that maintaining our reputation is necessary to continue to attract and retain customers. Furthermore, a market perception that our products and/or services are not satisfactory to our customers, even if factually incorrect or based on isolated incidents, could damage our reputation, diminish the value of our products, undermine the trust and credibility we have established and have a negative impact on our ability to attract and retain customers and could adversely impact our our sales, profitability and the implementation of our growth strategy.

**53. *The success of our business and operations are dependent upon certain quality accreditations which are valid for a limited time period. An inability to renew such accreditations in a timely manner, or at all, may adversely affect our business and prospects.***

We have been awarded the Integrated Management System (IMS) certification by SGS India Limited, and are now certified for three management systems, which are: Quality Management System (QMS) – ISO 9001:2015 (India, South Africa), Environment Management System (EMS) – ISO 14001:2004 (India) and Occupational Health & Safety Management System (OHSMS) – OHSAS 18001:2007 (India). Receipt of certifications and accreditations under the standards of quality is important for the success and wide acceptability of our products. If we fail to comply with the requirements for applicable quality standards, or if we are otherwise unable to obtain or renew such quality accreditations in the future, in a timely manner, or at all, our business and prospects may be adversely affected.

54. ***This Red Herring Prospectus contains information from industry sources including the industry report commissioned from Frost & Sullivan, which has been paid by us and prepared for the specific purpose for this Offer. Prospective investors are advised not to place undue reliance on such information.***

This Red Herring Prospectus includes information derived from third party industry sources and from a report commissioned by us titled “*Global Market Assessment – Select Mineral Processing Equipment*” dated October 12, 2021 prepared by Frost & Sullivan (“**F&S Report**”), pursuant to an engagement with our Company dated April 9, 2021. We cannot guarantee the accuracy, adequacy or completeness of any information in the Report and other information under “**Industry Overview**” on page 108. Moreover, the industry sources including the F&S Report contains certain industry and market data, based on certain assumptions.

Further, the F&S Report uses certain methodologies for market sizing and forecasting. There are no standard data gathering methodologies in the markets in which we operate, and methodologies and assumptions vary widely among different industry sources. Such assumptions may change based on various factors. We cannot assure you that such assumptions are correct or will not change and, accordingly, our position in the market may differ from that presented in this Red Herring Prospectus.

Further, the Report or any other industry data or sources are not recommendations to invest in our Company. Prospective investors are advised not to place undue reliance on the F&S Report or extracts thereof as included in this Red Herring Prospectus, when making their investment decisions. See “**Certain Conventions, Use of Financial Information and Market Data and Currency of Presentation**” and “**Industry Overview**” on pages 12 and 108, respectively.

55. ***Our Promoters and Promoter Group will continue to retain control over our Company after completion of the Offer, which will allow them to influence the outcome of matters submitted for approval of our Shareholders.***

The aggregate pre-Offer shareholding of our Promoter and Promoter Group, as on the date of this Red Herring Prospectus is 85.17% of the pre-Offer issued, subscribed and paid-up Equity Share capital of our Company. Consequently, our Promoter and Promoter Group will continue to exercise significant control over us after completion of the Offer, including being able to determine matters requiring Shareholders’ approval or approval of our Board of Directors.

Our Promoter and Promoter Group may take or block actions with respect to our business, which may conflict with our interests or the interests of our minority Shareholders. By exercising their control, our Promoter and Promoter Group could delay, defer or cause a change of our control or a change in our capital structure, delay, defer or cause a merger, consolidation, takeover or other business combination involving us, discourage or encourage a potential acquirer from making a tender offer or otherwise attempting to obtain control of us even if such actions may be beneficial for the Company. For details, see “**Capital Structure**” on page 79.

56. ***We are subject to risks arising from interest rate fluctuations, which could adversely affect our results of operations planned expenditures and cash flows.***

As of June 30, 2021, 96.57% of our borrowings was at floating interest rates while 3.43% of our borrowings was at fixed interest rate. Further 49.72% of borrowings under floating interest rate are hedged against interest rate risks. If the interest rates of our existing or future borrowings, availed by our Company or our Subsidiaries, increases significantly, our cost of funds will increase. A further increase in interest rates may have an adverse effect on our results of operations and financial condition. While we could consider refinancing the loan or hedging interest rate risks in appropriate cases, there

can be no assurance that we will be able to do so on commercially reasonable terms or at all, that our counterparties will perform their obligations, or that these agreements, if entered into, will protect us adequately against interest rate risks. Further, if such arrangements do not protect us adequately against interest rate risks, they would result in higher costs.

57. ***We have entered into transactions with related parties. These or any future related party transactions may potentially involve conflicts of interest and there can be no assurance that we could not have achieved better terms, had such arrangements been entered into with unrelated parties.***

We have, in the ordinary course of business entered into various transactions with related parties, including our Subsidiaries from time to time. These transactions principally include remuneration to executive Directors and Key Managerial Personnel and consideration paid to TPW Engineering Limited, one of our Group Companies, in relation to acquiring the leasehold rights. We cannot assure you that we could not have achieved more favourable terms had such transactions been entered into with unrelated parties. It is likely that we may enter into related party transactions in the future. Although going forward, all material related party transactions that we may enter into, will be subject to the Board's or Shareholders' approval, as necessary under the Companies Act 2013 and the SEBI Listing Regulations, there can be no assurance that such transactions, individually or in the aggregate, will not have an adverse effect on our financial condition and results of operations or that we could not have achieved more favourable terms if such transactions had not been entered into with related parties. Such related party transactions may potentially involve conflicts of interest. For details, see "***Financial Information – Restated Consolidated Financial Information – Annexure V- Notes to the Restated Consolidated Financial Information – Note 46 – Related Party Transactions***" on page 287. These related party transactions entered into by us, were in compliance with the Companies Act.

We cannot assure you that such transactions, individually or in the aggregate, will always be in the best interests of our minority Shareholders and will not have an adverse effect on our business, results of operations, financial condition and cash flows. We cannot assure you that related party transactions could not have been made on more favourable terms with unrelated parties. Further, there is no assurance that our related party transactions in future would be on terms favourable to us when compared to similar transactions with unrelated or third parties or that our related party transactions, individually or in the aggregate, will not have an adverse effect on our financial condition.

58. ***Certain of our Promoters and directors hold Equity Shares in our Company and are interested in our Company's performance in addition to remuneration and reimbursement of expenses.***

Certain of our Promoters and Directors are interested in our Company to the extent of their shareholding in our Company and the dividend entitlement received from our Company, in addition to the normal remuneration or benefits and reimbursement of expenses by our Company. We cannot assure you that our Promoters and Directors, or any other interested Director in the future, would always exercise their rights as Shareholders to the benefit and best interest of our Company. As a result, such Promoters and Directors or any other interested Director in the future will continue to exercise significant control over our Company, including being able to control the composition of our Board of Directors and determine decisions requiring simple or special majority voting, and our other Shareholders may be unable to affect the outcome of such voting.

Further our Promoters and Directors, or any other interested Director in the future may take or block actions with respect to our business, which may conflict with our best interests or the interests of other minority Shareholders, such as actions with respect to future capital raising or acquisitions. We cannot assure you that, such Promoters and Directors or any other interested Director in the future will always act to resolve any conflicts of interest in our favour, thereby adversely affecting our business and results of operations and prospects. See "***Capital Structure***" on page 79.

59. ***Our insurance coverage may not be adequate to protect us against all potential losses, which may have a material adverse effect on our business, financial condition and results of operations.***

Our principal types of coverage for our Company as well as our manufacturing facilities include among others, protection from fire, special perils, burglary, machinery breakdown, plant and machine, product liability, financial loss and a variety of marine and employee insurance policies such as group personal accident policy and workmen compensation policy. We cannot assure you that any claim under the insurance policies maintained by us will be honoured fully, in part or on time, or that we have taken out

sufficient insurance to cover all our losses. Further, we may not have identified every risk, and further may not be insured against every risk, including operational risks that may occur, and the occurrence of an event that causes losses in excess of the limits specified in our policies, or losses arising from events or risks not covered by insurance policies or due to the same being inadequate.

In addition, our insurance coverage expires from time to time. We apply for the renewal of our insurance coverage in the normal course of our business, but we cannot assure you that such renewals will be granted in a timely manner, at acceptable cost or at all. Additionally, in future, we may be required to bear increased premiums for our insurance to provide coverage for pandemics such as COVID-19. Our insurance coverage is 292% of carrying value of property, plant and equipment, investment property and other intangibles assets amounting to ₹1,751.77 million as of June 30, 2021.

We have claimed an amount of ₹6.87 million, ₹0.76 million and ₹8.51 million in Fiscals 2021, 2020 and 2019, respectively under the insurance policies in relation to events such as damage of certain factory sheds, leakage in materials received and other events related to the operations of our Company and Subsidiaries. We have received a settlement amount of ₹3.69 million, ₹0.60 million and ₹7.66 million against these insurance claims in the respective financial years. Further, we have not made any claims under the insurance policies in the three months period ended June 30, 2021.

To the extent that we suffer loss or damage, or successful assertion of one or more large claims against us for events for which we are not insured, or for which we did not obtain or maintain insurance, or which is not covered by insurance, exceeds our insurance coverage or where our insurance claims are rejected, the loss would have to be borne by us and our results of operations, financial performance and cash flows could be adversely affected. See “**Business - Insurance**” on page 164.

**60. *Our ability to pay dividends in the future will depend on our future earnings, financial condition, cash flows, working capital requirements, capital expenditure and restrictive covenants in our financing arrangements.***

Our ability to pay dividends in the future will depend on our future earnings, cash flows, financial condition, working capital requirements, capital expenditure, applicable Indian legal restrictions and other factors. The declaration and payment of dividends, if any, will be recommended by our Board and approved by the Shareholders, at their discretion, subject to the provisions of the Articles of Association, the Dividend Distribution Policy and applicable law, including the Companies Act 2013. There can be no assurance that we will pay dividends. We may decide to retain all of our earnings to finance the development and expansion of our business or conserve cash to cope with the disruption in our business operations due to COVID-19 pandemic and, therefore, may not declare dividends on our Equity Shares. Additionally, in the future, we may be restricted by the terms of our financing agreements in making dividend payments unless otherwise agreed with our lenders. See “**Dividend Policy**” and “**Financial Indebtedness**” on pages 206 and 314, respectively.

**61. *We have had negative cash flows in the past, and may have negative cash flows in the future. Negative cash flows could adversely affect our cash flow requirements, our ability to operate our business and implement our growth plans, thereby affecting our financial performance.***

We have in the three preceding Financial Years, and may in future, experience negative cash flows from investing and financing activities. For details, see “**Restated Consolidated Financial Information - Restated Consolidated Statement of Cash Flows**” and “**Management’s Discussion and Analysis of Financial Condition and Results of Operations**” on pages 224 and 318, respectively. We cannot assure you that our net cash flows will be positive in the future. Negative cash flows over extended periods, or significant negative cash flows in the short term, could materially impact our ability to operate our business and implement our growth plans. As a result, our cash flows, business, prospects, results of operations and financial condition may be materially and adversely affected.

## External Risk Factors

### *Risks Relating to India*

**62. *Political, economic or other factors that are beyond our control may have an adverse effect on our business and results of operations.***

The Indian economy and its securities markets are influenced by economic developments and volatility in securities markets in other countries. Investors' reactions to developments in one country may have adverse effects on the market price of securities of companies located elsewhere, including India. Adverse economic developments, such as rising fiscal or trade deficit, in other emerging market countries may also affect investor confidence and cause increased volatility in Indian securities markets and indirectly affect the Indian economy in general. Any of these factors could depress economic activity and restrict our access to capital, which could have an adverse effect on our business, financial condition and results of operations and reduce the price of our Equity Shares. Any financial disruption could have an adverse effect on our business, future financial performance, shareholders' equity and the price of our Equity Shares.

We are dependent on domestic, regional and global economic and market conditions. Our performance, growth and market price of our Equity Shares are and will be dependent to a large extent on the health of the economy in which we operate. There have been periods of slowdown in the economic growth of India. Demand for our services may be adversely affected by an economic downturn in domestic, regional and global economies. Economic growth in the countries in which we operate is affected by various factors including domestic consumption and savings, balance of trade movements, namely export demand and movements in key imports, global economic uncertainty and liquidity crisis, volatility in exchange currency rates, and annual rainfall which affects agricultural production. Consequently, any future slowdown in the Indian economy could harm our business, results of operations and financial condition. Also, a change in the government or a change in the economic and deregulation policies could adversely affect economic conditions prevalent in the areas in which we operate in general and our business in particular and high rates of inflation in India could increase our costs without proportionately increasing our revenues, and as such decrease our operating margins.

**63. *Natural disasters, fires, epidemics, pandemics, acts of war, terrorist attacks, civil unrest and other events could materially and adversely affect our business.***

Natural disasters (such as typhoons, flooding and earthquakes), epidemics, pandemics such as COVID-19, acts of war, terrorist attacks and other events, many of which are beyond our control, may lead to economic instability, including in India or globally, which may in turn materially and adversely affect our business, financial condition and results of operations. Our operations may be adversely affected by fires, natural disasters and/or severe weather, which can result in damage to our property or inventory and generally reduce our productivity and may require us to evacuate personnel and suspend operations. For instance, West Bengal was affected by the Amphan cyclone in May, 2020 and Yaas cyclone in May, 2021 while Gujarat was affected by Tauktae cyclone in May, 2021. Any terrorist attacks or civil unrest as well as other adverse social, economic and political events in India or countries to who we export our products could have a negative effect on us. Such incidents could also create a greater perception that investment in Indian companies involves a higher degree of risk and could have an adverse effect on our business and the price of the Equity Shares. A number of countries in Asia, including India, as well as countries in other parts of the world, are susceptible to contagious diseases and, for example, have had confirmed cases of diseases such as the highly pathogenic H7N9, H5N1 and H1N1 strains of influenza in birds and swine and more recently, the COVID-19 virus. A worsening of the current outbreak of COVID-19 pandemic or future outbreaks of COVID-19 virus or a similar contagious disease could adversely affect the Indian economy and economic activity in the region. As a result, any present or future outbreak of a contagious disease could have a material adverse effect on our business and the trading price of the Equity Shares.

**64. *A downgrade in ratings of India, may affect the trading price of the Equity Shares.***

Our borrowing costs and our access to the debt capital markets depend significantly on the credit ratings of India. India's sovereign rating by Fitch was decreased from BBB with a "stable" outlook to BBB with a "negative" outlook (Fitch) in June 2020. In May 2021, DBRS changed India's sovereign rating from BBB with a "negative" outlook to BBB (low) with a "stable" outlook. Further, in October 2021, Moody



affirmed India's sovereign rating of Baa3 with a "stable" outlook which has been upgraded from 'negative'. India's sovereign rating from S&P is BBB- with a "stable" outlook. Any adverse revisions to India's credit ratings for domestic and international debt by international rating agencies may adversely impact our ability to raise additional financing. A downgrading of India's credit ratings may occur, for example, upon a change of government tax or fiscal policy, which are outside our control. This could have an adverse effect on our ability to fund our growth on favourable terms and consequently adversely affect our business and financial performance and the price of the Equity Shares.

**65. *Financial instability in other countries may cause increased volatility in Indian financial markets.***

The Indian market and the Indian economy are influenced by economic and market conditions in other countries, including conditions in the United States, Europe and certain emerging economies in Asia. Financial turmoil in Asia, Russia and elsewhere in the world in recent years has adversely affected the Indian economy. Any worldwide financial instability may cause increased volatility in the Indian financial markets and, directly or indirectly, adversely affect the Indian economy and financial sector and us. Although economic conditions vary across markets, loss of investor confidence in one emerging economy may cause increased volatility across other economies, including India. Financial instability in other parts of the world could have a global influence and thereby negatively affect the Indian economy. Financial disruptions could materially and adversely affect our business, prospects, financial condition, results of operations and cash flows. Further, economic developments globally can have a significant impact on our principal markets. Concerns related to a trade war between large economies may lead to increased risk aversion and volatility in global capital markets and consequently have an impact on the Indian economy. Following the United Kingdom's exit from the European Union ("**Brexit**"), there remains significant uncertainty around the impact of Brexit on the general economic conditions in the United Kingdom and the European Union and any consequential impact on global financial markets.

In addition, China is one of India's major trading partners and there are rising concerns of a possible slowdown in the Chinese economy as well as a strained relationship with India, which could have an adverse impact on the trade relations between the two countries. In response to such developments, legislators and financial regulators in the United States and other jurisdictions, including India, implemented a number of policy measures designed to add stability to the financial markets. However, the overall long-term effect of these and other legislative and regulatory efforts on the global financial markets is uncertain, and they may not have the intended stabilizing effects. Any significant financial disruption could have a material adverse effect on our business, financial condition and results of operation. These developments, or the perception that any of them could occur, have had and may continue to have a material adverse effect on global economic conditions and the stability of global financial markets and may significantly reduce global market liquidity, restrict the ability of key market participants to operate in certain financial markets or restrict our access to capital. This could have a material adverse effect on our business, financial condition and results of operations and reduce the price of the Equity Shares.

**66. *If there is any change in laws or regulations, including taxation laws, or their interpretation, such changes may significantly affect our financial statements***

Any change in Indian tax laws could have an effect on our operations. For instance, the Taxation Laws (Amendment) Ordinance, 2019, a new tax ordinance issued by India's Ministry of Finance on September 20, 2019, prescribes certain changes to the income tax rate applicable to companies in India. According to this new ordinance, companies can henceforth voluntarily opt in favor of a concessional tax regime (subject to no other special benefits/exemptions being claimed), which would ultimately reduce the effective tax rate for Indian companies from 34.94% to approximately 25.17%. While we have opted for the concessional regime, any such future amendments may affect our other benefits such as exemption for income earned by way of dividend from investments in other domestic companies and units of mutual funds, exemption for interest received in respect of tax free bonds, and long-term capital gains on equity shares if withdrawn by the statute in the future, and the same may no longer be available to us. Any adverse order passed by the appellate authorities/ tribunals/ courts would have an effect on our profitability.

The application of various Indian tax laws, rules and regulations to our business, currently or in the future, is subject to interpretation by the applicable taxation authorities. For instance, the Government of India implemented a comprehensive national GST regime with effect from July 1, 2017 that combines taxes and levies by the central and state governments into a unified rate structure. There can be no

assurance that future clarifications by the Government of India on the GST regime would be favorable to us. If such tax laws, rules and regulations are amended, new adverse laws, rules or regulations are adopted or current laws are interpreted adversely to our interests, the results could increase our tax payments (prospectively or retrospectively) and/or subject us to penalties. The General Anti-Avoidance Rules (“GAAR”) also became effective from April 1, 2017. The tax consequences of the GAAR provisions being applied to an arrangement could result in denial of tax benefit amongst other consequences. In the absence of any precedents on the subject, the application of these provisions is uncertain and may or may not have an adverse tax impact on us. Additionally, the Government of India had announced the union budget for Fiscal 2022, pursuant to which the Finance Act, 2021 has been enacted. As such, there is no certainty on the impact that the Finance Act, 2021 may have on our business and operations or on the industry in which we operate.

The Government of India has passed new laws relating to social security, occupational safety, industrial relations and wages namely, the Code on Social Security, 2020, the Occupational Safety, Health and Working Conditions Code, 2020, the Industrial Relations Code, 2020 and the Code on Wages, 2019, respectively which were to take effect from April 1, 2021 (collectively, the “Labour Codes”). The Government of India has deferred the effective date of the Labour Codes and they shall come into force from such date as may be notified by the Government. Further, the Code on Social Security, 2020 (“**Social Security Code**”) will impact overall employee expenses and, in turn, could impact the profitability of our Company. Under the Social Security Code, a new concept of deemed remuneration has been introduced, such that where an employee receives more than half (or such other percentage as may be notified by the Central Government), of their total remuneration in the form of allowances and other amounts that are not included within the definition of wages under the Social Security Code, the excess amount received shall be deemed as remuneration and accordingly be added to wages for the purposes of the Social Security Code and the compulsory contribution to be made towards the employees’ provident fund.

We may incur increased costs and other burdens relating to compliance with such new requirements, which may also require significant management time and other resources, and any failure to comply may adversely affect our business, results of operations and prospects. Uncertainty in the applicability, interpretation or implementation of any amendment to, or change in, governing law, regulation or policy, including by reason of an absence, or a limited body, of administrative or judicial precedent may be time consuming as well as costly for us to resolve and may impact the viability of our current businesses or restrict our ability to grow our businesses in the future. In addition, unfavourable changes in or interpretations of existing, or the promulgation of new laws, rules and regulations including foreign investment laws governing our business, operations and group structure could result in us being deemed to be in contravention of such laws or may require us to apply for additional approvals.

We cannot predict whether any new tax laws or regulations impacting our services will be enacted, what the nature and impact of the specific terms of any such laws or regulations will be or whether, if at all, any laws or regulations would have an adverse effect on our business.

**67. *If inflation were to rise in India, we might not be able to increase the prices of our services at a proportional rate in order to pass costs on to our clients thereby reducing our margins.***

Inflation rates in India have been volatile in recent years, and such volatility may continue in the future. India has experienced high inflation in the past. Increased inflation can contribute to an increase in interest rates and increased costs to our business, including increased costs of transportation, wages, raw materials and other expenses relevant to our business.

High fluctuations in inflation rates may make it more difficult for us to accurately estimate or control our costs. Any increase in inflation in India can increase our expenses, which we may not be able to adequately pass on to our clients, whether entirely or in part, and may adversely affect our business and financial condition. In particular, we might not be able to reduce our costs or increase the price of our products to pass the increase in costs on to our clients. In such case, our business, results of operations, cash flows and financial condition may be adversely affected.

Further, the Government of India has previously initiated economic measures to combat high inflation rates, and it is unclear whether these measures will remain in effect. There can be no assurance that Indian inflation levels will not worsen in the future.

**68. *Rights of shareholders under Indian laws may be more limited than under the laws of other jurisdictions.***

Indian legal principles related to corporate procedures, directors' fiduciary duties and liabilities, and shareholders' rights may differ from those that would apply to a company in another jurisdiction. Shareholders' rights including in relation to class actions, under Indian law may not be as extensive as shareholders' rights under the laws of other countries or jurisdictions. Investors may have more difficulty in asserting their rights as shareholder in an Indian company than as shareholder of a corporation in another jurisdiction.

**69. *A third party could be prevented from acquiring control of us post this Issue, because of anti-takeover provisions under Indian law.***

As a listed Indian entity, there are provisions in Indian law that may delay, deter or prevent a future takeover or change in control of our Company. Under the Takeover Regulations, an acquirer has been defined as any person who, directly or indirectly, acquires or agrees to acquire shares or voting rights or control over a company, whether individually or acting in concert with others. Although these provisions have been formulated to ensure that interests of investors/shareholders are protected, these provisions may also discourage a third party from attempting to take control of our Company subsequent to completion of the Issue. Consequently, even if a potential takeover of our Company would result in the purchase of the Equity Shares at a premium to their market price or would otherwise be beneficial to our shareholders, such a takeover may not be attempted or consummated because of Takeover Regulations.

**70. *Investors may not be able to enforce a judgment of a foreign court against us.***

Our Company is a company incorporated under the laws of India. A majority of our Directors and officers are residents of India and a substantial portion of our assets and such persons are located in India. As a result, it may not be possible for investors to effect service of process upon our Company or such persons in jurisdictions outside India, or to enforce judgments obtained against such parties outside India. Furthermore, it is unlikely that an Indian court would enforce foreign judgments if that court was of the view that the amount of damages awarded was excessive or inconsistent with public policy, or if judgments are in breach or contrary to Indian law. In addition, a party seeking to enforce a foreign judgment in India is required to obtain approval from the RBI to execute such a judgment or to repatriate outside India any amounts recovered.

Recognition and enforcement of foreign judgments is provided for under Section 13 and Section 44A of the Code of Civil Procedure, 1908. India has reciprocal recognition and enforcement of judgments in civil and commercial matters with only a limited number of jurisdictions, such as the United Kingdom, Singapore and Hong Kong. In order to be enforceable, a judgment from a jurisdiction with reciprocity must meet certain requirements established in the Indian Code of Civil Procedure, 1908. The CPC only permits the enforcement and execution of monetary decrees in the reciprocating jurisdiction, not being in the nature of any amounts payable in respect of taxes, other charges, fines or penalties. Judgments or decrees from jurisdictions which do not have reciprocal recognition with India, including the United States, cannot be enforced by proceedings in execution in India. Therefore, a final judgment for the payment of money rendered by any court in a non-reciprocating territory for civil liability, whether or not predicated solely upon the general laws of the non-reciprocating territory, would not be directly enforceable in India. The party in whose favour a final foreign judgment in a non-reciprocating territory is rendered may bring a fresh suit in a competent court in India based on the final judgment within three years of obtaining such final judgment. However, it is unlikely that a court in India would award damages on the same basis as a foreign court if an action were brought in India or that an Indian court would enforce foreign judgments if it viewed the amount of damages as excessive or inconsistent with the public policy in India.

***Risks Relating to the Equity Shares and this Issue***

**71. *The trading volume and market price of the Equity Shares may be volatile following the Issue.***

The market price of the Equity Shares may fluctuate as a result of, among other things, the following factors, some of which are beyond our control:

- quarterly variations in our results of operations;

- results of operations that vary from the expectations of securities analysts and investors;
- results of operations that vary from those of our competitors;
- changes in expectations as to our future financial performance, including financial estimates by research analysts and investors;
- a change in research analysts' recommendations;
- announcements by us or our competitors of significant acquisitions, strategic alliances, joint operations or capital commitments;
- announcements by third parties or governmental entities of significant claims or proceedings against us;
- new laws and governmental regulations applicable to our industry;
- additions or departures of Key Managerial Personnel;
- changes in exchange rates;
- fluctuations in stock market prices and volume; and
- general economic and stock market conditions.

Changes in relation to any of the factors listed above could adversely affect the price of the Equity Shares.

**72. *The Offer Price of the Equity Shares may not be indicative of the market price of the Equity Shares after the Issue.***

The Offer Price of the Equity Shares will be determined by our Company in consultation with the Book Running Lead Manager through the Book Building Process. This price will be based on numerous factors, as described under “*Basis for Offer Price*” on page 100 and may not be indicative of the market price for the Equity Shares after the Issue. The market price of the Equity Shares could be subject to significant fluctuations after the Issue, and may decline below the Offer Price. We cannot assure you that you will be able to resell their Equity Shares at or above the Offer Price.

**73. *The Equity Shares have never been publicly traded and the Issue may not result in an active or liquid market for the Equity Shares. Further, the price of the Equity Shares may be volatile, and the investors may be unable to resell the Equity Shares at or above the Offer Price, or at all.***

Prior to the Issue, there has been no public market for the Equity Shares, and an active trading market on the stock exchanges may not develop or be sustained after the Issue. Listing and quotation does not guarantee that a market for the Equity Shares will develop, or if developed, the liquidity of such market for the Equity Shares. The market price of the Equity Shares may be subject to significant fluctuations in response to, among other factors, variations in our operating results, market conditions specific to the industry we operate in, developments relating to India and volatility in the Stock Exchanges and securities markets elsewhere in the world.

**74. *You may be subject to Indian taxes arising out of capital gains on the sale of our Equity Shares.***

Under the current Indian tax laws and regulations, capital gains arising from the sale of equity shares in an Indian company are generally taxable in India. A securities transaction tax (“**STT**”) is levied both at the time of transfer and acquisition of the equity shares (unless exempted under a prescribed notification), and the STT is collected by an Indian stock exchange on which equity shares are sold. Any gain realized on the sale of equity shares held for more than 12 months, which are sold using any other platform other than on a recognized stock exchange and on which no STT has been paid, are subject to long term capital gains tax in India. Such long term capital gains exceeding ₹100,000 arising from the sale of listed equity shares on the stock exchange are subject to tax at the rate of 10% (plus applicable surcharge and cess). Unrealized capital gains earned on listed equity shares up to January 31, 2018 continue to be tax-exempted in such cases. Further, STT will be levied and collected by an Indian stock exchange if the equity shares are sold on a stock exchange. With respect to capital gains arising in an off market sale,

long term capital gains are subject to tax at the rate of 10% (plus applicable surcharge and cess) without the exemption of ₹100,000. Short-term capital gains, arising from the sale of such equity shares on a stock exchange would be subject to tax at the rate of 15% (plus applicable surcharge and cess), while short term capital gains arising in an off-market sale would be subject to tax at a higher rate of 40% (plus applicable surcharge and cess) in the case of foreign companies and 30% (plus applicable surcharge and cess) in the case of other non-resident taxpayers.

The Finance Act, 2019 amended the Indian Stamp Act, 1899 with effect from July 1, 2020. It clarified that, in the absence of a specific provision under an agreement, the liability to pay stamp duty in case of sale of securities through stock exchanges will be on the buyer, while in other cases of transfer for consideration through a depository, the onus will be on the transferor. The stamp duty for transfer of securities other than debentures, on a delivery basis is specified at 0.015% and on a non-delivery basis is specified at 0.003% of the consideration amount. As such, there is no certainty on the impact that the Finance Act, 2019 may have on our business and operations.

Further, any gain realized on the sale of listed equity shares held for a period of 12 months or less will be subject to short term capital gains tax in India. In cases where the seller is a non-resident, capital gains arising from the sale of the equity shares will be partially or wholly exempt from taxation in India in cases where the exemption from taxation in India is provided under a treaty between India and the country of which the seller is resident. Additionally, the Finance Act, 2020 does not require dividend distribution tax to be payable in respect of dividends declared, distributed or paid by a domestic company after March 31, 2020, and accordingly, such dividends would not be exempt in the hands of the shareholders, both resident as well as non-resident. Historically, Indian tax treaties do not limit India's ability to impose tax on capital gains. As a result, residents of other countries may be liable for tax in India as well as in their own jurisdiction on a gain upon the sale of the equity shares.

**75. *Investors will not be able to sell immediately on an Indian stock exchange any of the Equity Shares they purchase in the Issue.***

The Equity Shares may not be listed on the Stock Exchanges. Pursuant to applicable Indian laws, certain actions must be completed before the Equity Shares can be listed and trading in the Equity Shares can commence. Investors' book entry, or 'demat' accounts with depository participants in India, are expected to be credited with the Equity Shares within one working day of the date on which the Basis of Allotment is approved by the Stock Exchanges. The Allotment of Equity Shares in the Offer and the credit of such Equity Shares to the applicant's demat account with depository participant could take approximately six working days from the Bid Closing Date (or such other period as prescribed under applicable laws) and trading in the Equity Shares upon receipt of final listing and trading approvals from the Stock Exchanges is expected to commence within six working days of the Bid Closing Date (or such other period as prescribed under applicable laws). There could be a failure or delay in listing of the Equity Shares on the Stock Exchanges. Any failure or delay in obtaining the approval or otherwise any delay in commencing trading in the Equity Shares would restrict investors' ability to dispose of their Equity Shares. There can be no assurance that the Equity Shares will be credited to investors' demat accounts, or that trading in the Equity Shares will commence, within the time periods specified in this risk factor. We could also be required to pay interest at the applicable rates if allotment is not made, refund orders are not dispatched or demat credits are not made to investors within the prescribed time periods.

**76. *Under Indian law, foreign investors are subject to investment restrictions that limit our ability to attract foreign investors, which may adversely affect the trading price of the Equity Shares.***

Under foreign exchange regulations currently in force in India, transfer of shares between non-residents and residents are freely permitted (subject to certain restrictions), if they comply with the pricing guidelines and reporting requirements specified by the RBI. If the transfer of shares, which are sought to be transferred, is not in compliance with such pricing guidelines or reporting requirements or falls under any of the exceptions referred to above, then a prior regulatory approval will be required. Additionally, shareholders who seek to convert Rupee proceeds from a sale of shares in India into foreign currency and repatriate that foreign currency from India require a no-objection or a tax clearance certificate from the Indian income tax authorities. We cannot assure investors that any required approval from the RBI or any other governmental agency can be obtained on any particular terms or at all. For further information, see "*Restrictions on Foreign Ownership of Indian Securities*" on page 380.

77. ***Significant differences exist between Ind AS and other accounting principles, such as U.S. GAAP and IFRS, which investors may be more familiar with and may consider material to their assessment of our financial condition.***

Our Restated Consolidated Financial Information for the three months period ended June 30, 2021 and Fiscal 2019, Fiscal 2020 and Fiscal 2021 have been prepared and presented in conformity with Ind AS. Ind AS differs in certain significant respects from IFRS, U.S. GAAP and other accounting principles with which prospective investors may be familiar in other countries. If our financial statements were to be prepared in accordance with such other accounting principles, our results of operations, cash flows and financial position may be substantially different. Prospective investors should review the accounting policies applied in the preparation of our financial statements, and consult their own professional advisers for an understanding of the differences between these accounting principles and those with which they may be more familiar. Any reliance by persons not familiar with Indian accounting practices on the financial disclosures presented in this Red Herring Prospectus should be limited accordingly.

78. ***Qualified Institutional Buyers and Non-Institutional Investors are not permitted to withdraw or lower their Bids (in terms of quantity of Equity Shares or the Bid Amount) at any stage after the submission of their Bid, and Retail Individual Investors are not permitted to withdraw their Bids after closure of the Bid/ Issue Closing Date.***

Pursuant to the SEBI ICDR Regulations, QIBs and Non-Institutional Investors are required to pay the Bid Amount on submission of the Bid and are not permitted to withdraw or lower their Bids (in terms of quantity of Equity Shares or the Bid Amount) at any stage after submitting a Bid. Retail Individual Investors can revise their Bids during the Bid/ Issue Period and withdraw their Bids until the Bid/ Issue Closing Date. While we are required to complete all necessary formalities for listing and commencement of trading of the Equity Shares on all Stock Exchanges where such Equity Shares are proposed to be listed, including Allotment, within six Working Days from the Bid/ Issue Closing Date or such other period as may be prescribed by the SEBI, events affecting the investors' decision to invest in the Equity Shares, including adverse changes in international or national monetary policy, financial, political or economic conditions, our business, results of operations, cash flows or financial condition may arise between the date of submission of the Bid and Allotment. We may complete the Allotment of the Equity Shares even if such events occur, and such events may limit the Investors' ability to sell the Equity Shares Allotted pursuant to the Issue or cause the trading price of the Equity Shares to decline on listing.

79. ***Investors may be restricted in their ability to exercise pre-emptive rights under Indian law and thereby may suffer future dilution of their ownership position.***

Under the Companies Act, a company having share capital and incorporated in India must offer its holders of equity shares pre-emptive rights to subscribe and pay for a proportionate number of shares to maintain their existing ownership percentages before the issuance of any new equity shares, unless the pre-emptive rights have been waived by adoption of a special resolution by holders of three-fourths of the equity shares voting on such resolution.

However, if the law of the jurisdiction the investors are in, does not permit them to exercise their pre-emptive rights without our Company filing an offering document or registration statement with the applicable authority in such jurisdiction, the investors will be unable to exercise their pre-emptive rights unless our Company makes such a filing. If we elect not to file a registration statement, the new securities may be issued to a custodian, who may sell the securities for the investor's benefit. The value such custodian receives on the sale of such securities and the related transaction costs cannot be predicted. In addition, to the extent that the investors are unable to exercise pre-emptive rights granted in respect of the Equity Shares held by them, their proportional interest in our Company would be reduced.

## SECTION III – INTRODUCTION

### THE OFFER

The following table summarizes details of the Offer:

<b>Offer</b>	
<i>The Offer consists of:</i>	
Offer for Sale <sup>(1)(2)</sup>	Up to 13,669,478 Equity Shares aggregating up to ₹ [•] million
<i>Of which:</i>	
<b>A. QIB Category</b> <sup>(3)(4)</sup>	Not more than 6,834,738 Equity Shares aggregating up to ₹ [•] million
<i>Of which:</i>	
Anchor Investor Portion	Not more than 4,100,842 Equity Shares
Net QIB (assuming the Anchor Investor Portion is fully subscribed)	2,733,896 Equity Shares
<i>Of which:</i>	
Available for allocation to Mutual Funds only (5% of the Net QIB Category)	136,695 Equity Shares
Balance of QIB Category for all QIBs including Mutual Funds	2,597,201 Equity Shares
<b>B. Non-Institutional Category</b> <sup>(3)</sup>	
	Not less than 2,050,422 Equity Shares aggregating up to ₹ [•] million
<b>C. Retail Portion</b> <sup>(3)</sup>	
	Not less than 4,784,318 Equity Shares aggregating up to ₹ [•] million
<b>Pre and post-Offer Equity Shares</b>	
Equity Shares outstanding prior to the Offer	66,293,149 Equity Shares
Equity Shares outstanding after the Offer	66,293,149 Equity Shares
<b>Use of proceeds of the Offer</b>	For further information, see “ <i>Objects of the Offer</i> ” beginning on page 98. Our Company will not receive any portion of the proceeds from the Offer.

(1) *The Offer has been authorized by a resolution of our Board dated April 30, 2021. Further, our Board has taken on record the approval for the Offer for Sale by the Selling Shareholders pursuant to its resolution dated August 16, 2021.*

(2) *The Equity Shares being offered by the Selling Shareholders have been held for a period of at least one year immediately preceding the date of the Draft Red Herring Prospectus with SEBI, and are eligible for being offered for sale pursuant to the Offer in terms of the SEBI ICDR Regulations. The Selling Shareholders, severally and not jointly, have confirmed and authorized their respective participation in the Offer for Sale, as stated below:*

S. No.	Name of the Selling Shareholder	Date of consent letter and corporate authorization, if applicable <sup>^</sup>	Maximum number of Offered Shares
<b>Promoter Selling Shareholders</b>			
	Madan Mohan Mohanka	August 16, 2021	3,314,657
	Manish Mohanka	August 16, 2021	662,931
<b>Investor Selling Shareholder</b>			
	Wagner Limited	Consent letter dated August 16, 2021 and resolution dated August 6, 2021	9,691,890 <sup>*</sup>
<b>Total</b>			<b>13,669,478</b>

<sup>^</sup>*Each Selling Shareholder, severally and not jointly, confirms that, as required under Regulation 8 of the SEBI ICDR Regulations, they have held the Equity Shares proposed to be offered and sold by them in the Offer or in the case of Wagner Limited, the CCPP that has converted into its portion of the Offered Shares, for a period of at least one year prior to the date of filing of the Draft Red Herring Prospectus. Therefore, the Equity Shares that will be offered by it in the Offer for Sale are eligible to be offered for sale in the Offer. For details, see “**Capital Structure**” on page 79.*

<sup>\*</sup>*Pursuant to resolutions dated November 10, 2021 passed by our Board and Shareholders, 8,692,281 CCPP held by Wagner Limited were converted to 8,692,281 Equity Shares. For details, see “**Capital Structure- Notes to the Capital Structure – Equity Share capital history of our Company**” and “**Capital Structure - Notes to the Capital Structure – Preference Share capital history of our Company**” on pages 79 and 82.*

(3) *Subject to valid bids being received at or above the Offer Price, undersubscription, if any, in any category, except in the QIB Category, would be allowed to be met with spill-over from any other category or combination of categories of Bidders at the discretion of our Company and the Selling Shareholders, in consultation with the BRLMs and the Designated Stock Exchange, subject to applicable laws. Under-subscription, if any, in the QIB Category (excluding the Anchor Investor Portion) will not be allowed to be met with spill-over from other categories or a combination of categories.*

(4) *Our Company and the Selling Shareholders, in consultation with the BRLMs, may allocate up to 60% of the QIB Category to Anchor Investors on a discretionary basis in accordance with the SEBI ICDR Regulations. One-third of the Anchor Investor Portion shall be*

*reserved for domestic Mutual Funds, subject to valid Bids being received from domestic Mutual Funds at or above the price at which Equity Shares are allocated to Anchor Investors in the Offer. In the event of under-subscription, or non-allocation in the Anchor Investor Portion, the balance Equity Shares shall be added to the QIB Category. For further information, see “Offer Procedure” beginning on page 356.*

Allocation to all categories, other than Anchor Investors, if any, and Retail Individual Investors, shall be made on a proportionate basis, subject to valid Bids received at or above the Offer Price, as applicable. The allocation to each Retail Individual Investor shall not be less than the minimum Bid Lot, subject to availability of Equity Shares in the Retail Category and the remaining available Equity Shares, if any, shall be allocated on a proportionate basis. For further information, see “**Offer Procedure**” beginning on page 380.



## SUMMARY FINANCIAL INFORMATION

The following tables set forth summary financial information derived from the Restated Consolidated Financial Information. The Restated Consolidated Financial Information has been prepared, based on audited consolidated financial statements as at and for the three months period ended June 30, 2021 and the Fiscals 2021, 2020 and 2019, of our Company and our Subsidiaries, along with our joint venture and comprises of the Restated Consolidated Statement of Assets and Liabilities as at June 30, 2021, March 31, 2021, March 31, 2020 and March 31, 2019, the Restated Consolidated Statement of Profit and Loss, the Restated Consolidated Statement of Changes in Equity and Restated Consolidated Statement of Cash Flows for the three months period ended June 30, 2021 and years ended March 31, 2021, March 31, 2020 and March 31, 2019, Notes to the Restated Consolidated Financial Information and Statement of Adjustments to the Audited Special Purpose Interim Consolidated Financial Statements as at and for the three months period ended June 30, 2021 and Audited Consolidated Financial Statements as at and for the years ended March 31, 2021, March 31, 2020 and March 31, 2019. The Restated Consolidated Financial Information have been prepared in accordance with the requirements of Section 26 of Companies Act, Paragraph (A) of Clause 11 (I) of Part A of Schedule VI of the SEBI ICDR Regulations and the Guidance Note on Reports in Company Prospectuses (Revised 2019) issued by the ICAI, and are presented in the section “*Financial Information*” beginning on page 207. The summary financial information presented below should be read in conjunction with the Restated Consolidated Financial Information, the notes and annexures thereto and the sections “*Financial Information*” and “*Management’s Discussion and Analysis of Financial Condition and Results of Operations*” on pages 207 and 318, respectively.

[REMAINDER OF THE PAGE HAS BEEN INTENTIONALLY LEFT BLANK]

Particulars	Annexure V Note	30 June 2021	31 March 2021	31 March 2020	31 March 2019
<b>ASSETS</b>					
<b>Non-current assets</b>					
Property, plant and equipment	3(a)	1,693.12	1,691.96	1,691.49	1,852.56
Right-of-Use Assets	3(b)	607.54	591.01	405.86	385.85
Capital work in progress	3(c)	71.04	68.59	62.22	16.42
Investment property	4	40.56	38.49	33.01	37.21
Goodwill	5	633.92	632.82	523.64	557.46
Other intangible assets	3(d)	18.09	7.13	5.34	7.43
Intangible assets under development	3(e)	-	-	23.93	23.93
Investments accounted for using the equity method	43(d)	275.33	269.22	244.66	234.64
Financial assets					
(i) Investments	6	-	181.85	166.58	151.39
(ii) Other financial assets	7	100.38	103.01	127.28	59.21
Non-current tax assets (net)	8	105.41	101.82	79.83	84.97
Deferred tax assets (net)	9	269.74	256.28	307.81	90.24
Other non-current assets	10	24.25	14.06	8.94	22.57
<b>Total non-current assets</b>		<b>3,839.38</b>	<b>3,956.24</b>	<b>3,680.59</b>	<b>3,523.88</b>
<b>Current assets</b>					
Inventories	11	2,078.66	1,586.31	1,326.30	1,210.58
Financial assets					
(i) Investments	12	1,878.98	1,561.92	1,166.63	382.15
(ii) Trade receivables and contract assets	13	1,697.76	2,208.64	1,852.18	2,103.24
(iii) Cash and cash equivalents	14	645.77	478.70	368.63	192.64
(iv) Other bank balances	15	9.80	5.40	0.48	4.38
(v) Other financial assets	16	52.07	42.27	30.98	44.70
Current tax assets (net)	17	7.28	15.49	30.54	13.14
Other current assets	18	352.02	328.42	416.82	427.97
<b>Total current assets</b>		<b>6,722.34</b>	<b>6,227.15</b>	<b>5,192.56</b>	<b>4,378.80</b>
<b>Total assets</b>		<b>10,561.72</b>	<b>10,183.39</b>	<b>8,873.15</b>	<b>7,902.68</b>
<b>EQUITY AND LIABILITIES</b>					
<b>Equity</b>					
Equity share capital	19A	576.01	576.01	576.01	576.01
Preference share capital	19B	86.92	86.92	86.92	86.92
Other equity	19C	5,648.59	5,474.29	3,961.96	3,348.12
<b>Equity attributable to the owners of the company</b>		<b>6,311.52</b>	<b>6,137.22</b>	<b>4,624.89</b>	<b>4,011.05</b>
<b>Equity attributable to the owners of the non controlling interest</b>		<b>0.00<sup>^</sup></b>	<b>0.00<sup>^</sup></b>	<b>0.00<sup>^</sup></b>	<b>0.00<sup>^</sup></b>
<b>Total equity</b>		<b>6,311.52</b>	<b>6,137.22</b>	<b>4,624.89</b>	<b>4,011.05</b>
<b>Liabilities</b>					
<b>Non-current liabilities</b>					
Financial liabilities					
(i) Borrowings	20	816.85	862.10	951.07	597.33
(ii) Lease Liabilities	3(b)	261.89	237.81	247.89	243.63
(iii) Other financial liabilities	21	82.66	89.23	133.07	33.74
Deferred tax liabilities (net)	22	74.81	87.61	67.42	51.42
<b>Total non-current liabilities</b>		<b>1,236.21</b>	<b>1,276.75</b>	<b>1,399.45</b>	<b>926.12</b>
<b>Current liabilities</b>					
Financial liabilities					
(i) Borrowings	23	1,025.53	1,015.92	1,488.27	1,529.57
(ii) Lease Liabilities	3(b)	75.57	80.89	92.81	64.56
(iii) Trade payables					
(a) Total outstanding dues of micro and small enterprises	24	38.26	42.20	32.00	33.58
(b) Total outstanding dues of creditors other than micro and small enterprises	24	1,136.18	944.90	620.96	773.25
(iv) Other financial liabilities	25	122.34	126.37	156.17	127.58
Provisions	26	169.44	146.37	108.66	119.49
Current tax liabilities (net)	27	109.79	96.53	15.44	43.70
Other current liabilities	28	336.88	316.24	334.50	273.78
<b>Total current liabilities</b>		<b>3,013.99</b>	<b>2,769.42</b>	<b>2,848.81</b>	<b>2,965.51</b>
<b>Total liabilities</b>		<b>4,250.20</b>	<b>4,046.17</b>	<b>4,248.26</b>	<b>3,891.63</b>
<b>Total equity and liabilities</b>		<b>10,561.72</b>	<b>10,183.39</b>	<b>8,873.15</b>	<b>7,902.68</b>

<sup>^</sup>Amount is below the rounding off norm adopted by the Group

The above Restated Consolidated Statement of Assets and Liabilities should be read in conjunction with Notes to Restated Consolidated Financial Information appearing in Annexure - V and Statement of Adjustments to Audited Special Purpose Interim Consolidated Financial Statements as at and for the three months period ended 30 June 2021 and Audited Consolidated Financial Statements as at and for the years ended 31 March 2021, 31 March 2020 and 31 March 2019 appearing in Annexure - VI.

This is the Restated Consolidated Statement of Assets and Liabilities referred to in our report of even date

For Price Waterhouse & Co Bangalore LLP  
Firm Registration Number: 007567S/S-200012  
Chartered Accountants

For and on behalf of Board of Directors

Avijit Mukerji  
Partner  
Membership Number: 056155

Madan Mohan Mohanka  
Chairman  
DIN: 00049388

Mehul Mohanka  
Managing Director  
DIN: 00052134

Sudipta Bhowal  
Company Secretary

Manoj Kumar Agarwal  
Chief Financial Officer

Place : Kolkata  
Date : 10 November 2021

Place : Kolkata  
Date : 10 November 2021

Particulars	Annexure V Note	Three months period ended 30 June 2021	Year ended 31 March 2021	Year ended 31 March 2020	Year ended 31 March 2019
Revenue from operations	29	1,732.07	8,055.22	6,848.47	6,337.57
Other income	30	61.79	511.62	106.95	92.56
<b>Total income</b>		<b>1,793.86</b>	<b>8,566.84</b>	<b>6,955.42</b>	<b>6,430.13</b>
<b>Expenses</b>					
Cost of materials consumed	31	764.32	3,282.36	2,847.43	2,650.29
Changes in inventories of finished goods and work-in-progress	32	(78.85)	(44.46)	(109.07)	(76.46)
Employee benefits expense	33	350.25	1,226.70	1,153.34	1,113.91
Finance costs	34	36.13	172.78	214.39	236.02
Depreciation and amortisation expenses	35	105.00	401.80	383.55	377.55
Other expenses	36	461.34	1,715.82	1,891.44	1,682.36
<b>Total expenses</b>		<b>1,638.19</b>	<b>6,755.00</b>	<b>6,381.08</b>	<b>5,983.67</b>
<b>Restated profit before share of restated net profit of joint venture accounted for using equity method and tax</b>		<b>155.67</b>	<b>1,811.84</b>	<b>574.34</b>	<b>446.46</b>
<b>Share of restated net profit of joint venture accounted for using the equity method</b>	43(d)	<b>6.16</b>	<b>26.78</b>	<b>18.09</b>	<b>18.09</b>
<b>Restated profit before tax</b>		<b>161.83</b>	<b>1,838.62</b>	<b>592.43</b>	<b>464.55</b>
Income tax expense					
- Current tax	37	69.67	372.81	154.89	155.96
- Deferred tax	37	(26.66)	101.76	(217.50)	(18.11)
<b>Total tax expense/ (credit)</b>		<b>43.01</b>	<b>474.57</b>	<b>(62.61)</b>	<b>137.85</b>
<b>Restated total profit for the period/ year (A)</b>		<b>118.82</b>	<b>1,364.05</b>	<b>655.04</b>	<b>326.70</b>
<b>Restated other comprehensive income/ (loss)</b>					
<i>Items that will not be reclassified to profit or loss</i>					
(a) Remeasurement gain/ (loss) on post employment defined benefit plans		(2.40)	3.11	(6.36)	(4.87)
(b) Income tax related to above		0.60	(0.78)	2.22	1.70
(c) Share of restated other comprehensive income/ (loss) of joint venture accounted using the equity method		(0.05)	0.03	(0.02)	(0.75)
<i>Items that will be reclassified to profit or loss</i>					
(a) Exchange differences on translation of foreign operations		57.33	138.27	(45.11)	(84.49)
<b>Restated other comprehensive income/ (loss) for the period/ year, net of tax (B)</b>		<b>55.48</b>	<b>140.63</b>	<b>(49.27)</b>	<b>(88.41)</b>
<b>Restated total comprehensive income for the period/ year (A+B)</b>		<b>174.30</b>	<b>1,504.68</b>	<b>605.77</b>	<b>238.29</b>
Restated profit is attributable to:					
Owners of Tega Industries Limited		118.82	1,364.05	655.04	326.28
Non- Controlling interests		0.00 <sup>^</sup>	0.00 <sup>^</sup>	0.00 <sup>^</sup>	0.42
		<b>118.82</b>	<b>1,364.05</b>	<b>655.04</b>	<b>326.70</b>
Restated other comprehensive income/ (loss) is attributable to:					
Owners of Tega Industries Limited		55.48	140.63	(49.27)	(88.41)
Non- Controlling interests		0.00 <sup>^</sup>	0.00 <sup>^</sup>	0.00 <sup>^</sup>	-
		<b>55.48</b>	<b>140.63</b>	<b>(49.27)</b>	<b>(88.41)</b>
Restated total comprehensive income is attributable to:					
Owners of Tega Industries Limited		174.30	1,504.68	605.77	237.87
Non- Controlling interests		0.00 <sup>^</sup>	0.00 <sup>^</sup>	0.00 <sup>^</sup>	0.42
		<b>174.30</b>	<b>1,504.68</b>	<b>605.77</b>	<b>238.29</b>
<b>Restated earnings per equity share: [Nominal Value Per Share INR 10/-]</b>					
Basic	45	2.10	24.10	11.57	5.76
Diluted	45	1.78	20.48	9.84	4.90

<sup>^</sup>Amount is below the rounding off norm adopted by the Group

The above Restated Consolidated Statement of Profit and Loss should be read in conjunction with Notes to Restated Consolidated Financial Information appearing in Annexure - V and Statement of Adjustments to Audited Special Purpose Interim Consolidated Financial Statements as at and for the three months period ended 30 June 2021 and Audited Consolidated Financial Statements as at and for the years ended 31 March 2021, 31 March 2020 and 31 March 2019 appearing in Annexure - VI.

This is the Restated Consolidated Statement of Profit and Loss referred to in our report of even date

For Price Waterhouse & Co Bangalore LLP  
Firm Registration Number: 007567S/S-200012  
Chartered Accountants

For and on behalf of Board of Directors

Avijit Mukerji  
Partner  
Membership Number: 056155

Madan Mohan Mohanka  
Chairman  
DIN: 00049388

Mehul Mohanka  
Managing Director  
DIN: 00052134

Sudipta Bhowal  
Company Secretary

Manoj Kumar Agarwal  
Chief Financial Officer

Place : Kolkata  
Date : 10 November 2021

Place : Kolkata  
Date : 10 November 2021

Particulars	Three months period ended 30 June 2021	Year ended 31 March 2021	Year ended 31 March 2020	Year ended 31 March 2019
<b>A. Cash flow from Operating Activities</b>				
Restated Profit before tax	161.83	1,838.62	592.43	464.55
Adjustments for:				
Depreciation and amortisation expenses	105.00	401.80	383.55	377.55
Finance costs	28.50	138.79	194.78	225.25
Interest income	(1.12)	(4.56)	(4.15)	(4.35)
Allowance for expected credit loss (including bad debts and advances written off)	6.14	57.39	48.72	38.56
Claims/ Liquidating damages	0.47	14.47	2.69	34.38
Net fair value (gain) on investments classified at FVTPL	(21.34)	(78.13)	(37.35)	(21.31)
Mark to market (gain)/ loss on derivative instrument (net)	(8.23)	(61.59)	87.36	(20.86)
Payment on Derivative Settlement (net)	11.49	44.56	23.14	13.33
Liabilities/ Provisions no longer required written back	(0.29)	(12.80)	(53.60)	(19.60)
Net loss/(gain) on sale of property, plant and equipment including intangible assets (including loss on assets scrapped/ written off)	(0.60)	37.28	8.83	14.10
Dividend Income from investments measured at FVTPL	-	(11.81)	(4.45)	(0.87)
Share of restated profit of joint venture accounted for using the equity method	(6.16)	(26.78)	(18.09)	(18.09)
Provision for Warranty Expenses	4.83	23.29	8.99	9.76
Net (gain) on sale of investments classified at FVTPL	(0.81)	(2.50)	(0.25)	(13.49)
Loss on disposal of a subsidiary	-	-	-	3.63
Provision for slow moving/ non-moving and obsolete inventory	(1.02)	52.91	49.46	(8.97)
Other non cash items	(0.06)	(1.39)	-	-
Effect of unrealised exchange differences (net)	11.76	(18.85)	76.68	95.78
<b>Restated operating profit before working capital changes</b>	<b>290.39</b>	<b>2,390.70</b>	<b>1,358.74</b>	<b>1,169.35</b>
<b>Changes in Working Capital:</b>				
(Increase)/ decrease in Non Current/ Current financial and other assets	497.69	(396.65)	430.51	(389.90)
(Increase) in inventories	(491.33)	(312.92)	(165.18)	(100.18)
Increase/ (decrease) in Non Current/ Current financial and other liabilities/ provisions	247.47	324.69	(145.07)	153.70
<b>Cash Generated from Operations</b>	<b>544.22</b>	<b>2,005.82</b>	<b>1,479.00</b>	<b>832.97</b>
Direct Taxes paid (net of refunds)	(51.87)	(303.36)	(195.25)	(146.28)
<b>Net cash generated from operating activities</b>	<b>492.35</b>	<b>1,702.46</b>	<b>1,283.75</b>	<b>686.69</b>
<b>B. Cash flow from Investing Activities</b>				
Purchase of capital assets	(93.11)	(486.12)	(277.99)	(261.57)
Sale of capital assets	1.61	2.27	13.57	7.54
Proceeds from disposal of a subsidiary	-	-	-	7.45
Payment for purchase of investments	(319.98)	(1,659.56)	(1,244.30)	(606.96)
Proceeds from sale of investments	206.93	1,341.46	486.68	711.96
Deposits with bank placed	(2.16)	(111.02)	(202.36)	(325.19)
Deposits with bank matured	-	110.06	199.26	326.45
Interest received	0.95	3.37	5.42	3.86
Dividend received	-	2.25	6.75	2.25
<b>Net cash (used in) investing activities</b>	<b>(205.76)</b>	<b>(797.29)</b>	<b>(1,012.97)</b>	<b>(134.21)</b>
<b>C. Cash flow from Financing Activities</b>				
Proceeds from long term borrowings	-	171.46	697.59	-
Repayment of long term borrowings	(47.75)	(128.36)	(564.18)	(450.27)
Proceeds from/ (repayment of) short term borrowings (net)	(8.27)	(574.03)	45.48	(206.81)
Payment on Derivative Settlement (net)	(11.49)	(44.56)	(23.14)	(13.33)
Finance cost paid	(22.66)	(110.71)	(168.51)	(196.06)
Finance cost paid on account of Lease Liability	(6.54)	(26.52)	(25.71)	(29.23)
Repayment of Lease Liability	(21.88)	(77.32)	(53.56)	(36.42)
Dividends paid	-	(0.00 <sup>^</sup> )	(0.00 <sup>^</sup> )	(0.00 <sup>^</sup> )
Dividend distribution tax paid	-	-	-	(0.00 <sup>^</sup> )
<b>Net cash (used in) financing activities</b>	<b>(118.59)</b>	<b>(790.04)</b>	<b>(92.03)</b>	<b>(932.12)</b>
Net increase in cash and cash equivalents	168.00	115.13	178.75	(379.64)
Cash and cash equivalents at the beginning of the period/ year	478.70	368.63	192.64	576.91
Exchange differences on translation of foreign currency cash & cash equivalent	(0.93)	(5.06)	(2.76)	(4.63)
Cash & cash equivalents at the end of the period/ year	645.77	478.70	368.63	192.64
	<b>30 June 2021</b>	<b>31 March 2021</b>	<b>31 March 2020</b>	<b>31 March 2019</b>
<b>Cash and Cash Equivalents comprise :</b>				
Cash on hand	1.10	1.29	0.98	0.94
Balances with banks on current account	472.90	343.32	225.97	191.63
Balances with banks in deposit account (less than three months maturity)	171.77	134.09	141.68	0.07
	<b>645.77</b>	<b>478.70</b>	<b>368.63</b>	<b>192.64</b>

**Notes:**

- The above Restated Consolidated Statement of Cash Flows has been prepared under the Indirect Method as set out in Ind AS - 7 "Statement of Cash Flows".
- Cash flow from investing activities does not include dividend income on mutual funds which was reinvested in the mutual funds to the tune of INR NIL (31 March 2021: INR 11.81 Mn ; 31 March 2020: INR 4.45 Mn and 31 March 2019: INR 0.87 Mn) being non cash items.
- During the period/ year non-cash transaction from Investing and Financing Activities with respect to acquisition of Right-of-Use Assets with corresponding adjustments to Lease Liabilities INR 37.58 Mn (31 March 2021: INR 24.96 Mn ; 31 March 2020: INR 171.30 Mn and 31 March 2019: INR 14.94 Mn).

<sup>^</sup>Amount is below the rounding off norm adopted by the Group

The above Restated Consolidated Statement of Cash Flows should be read in conjunction with Notes to the Restated Consolidated Financial Information appearing in Annexure - V and Statement of Adjustments to the Audited Special Purpose Interim Consolidated Financial Statements as at and for the three months period ended 30 June 2021 and Audited Consolidated Financial Statements as at and for the years ended 31 March 2021, 31 March 2020 and 31 March 2019 appearing in Annexure - VI.

This is the Restated Consolidated Statement of Cash Flows referred to in our report of even date.

For Price Waterhouse & Co Bangalore LLP  
Firm Registration Number: 007567S-200012  
Chartered Accountants

For and on behalf of Board of Directors

Avijit Mukerji  
Partner  
Membership Number: 056155

Madan Mohan Mohanka  
Chairman  
DIN: 00049388

Mehul Mohanka  
Managing Director  
DIN: 00052134

Sudipta Bhowal  
Company Secretary

Manoj Kumar Agarwal  
Chief Financial Officer

## GENERAL INFORMATION

Our Company was incorporated as “Tega India Limited” under the Companies Act, 1956, as a public limited company, pursuant to a certificate of incorporation dated May 15, 1976, issued by the RoC. Our Company received a certificate of commencement of business on May 28, 1976, from the RoC. For further information on changes in name and registered office of our Company, see “*History and Certain Corporate Matters*” beginning on page 170.

**Company Registration Number:** 030532

**Corporate Identity Number:** U25199WB1976PLC030532

### Registered Office

147, Block-G  
New Alipore  
Kolkata 700 053  
West Bengal, India  
**Tel:** +91 33 3001 9000

### Corporate Office

Office Space No. 807, 8<sup>th</sup> Floor  
Godrej Waterside-Tower II, DP-5  
Bidhannagar, Salt Lake, Sector V  
Kolkata 700 091  
West Bengal, India

### Address of the Registrar of Companies

Our Company is currently registered with the Registrar of Companies located at the following address:

### Registrar of Companies

Nizam Palace  
2<sup>nd</sup> MSO Building  
2<sup>nd</sup> floor, 234/4, A.J.C.B. Road  
Kolkata 700 020  
West Bengal, India

### Board of Directors

The following table sets out the details regarding our Board as on the date of this Red Herring Prospectus:

<b>Name and Designation</b>	<b>DIN</b>	<b>Address</b>
Madan Mohan Mohanka <i>Chairman and Executive Director</i>	00049388	146, Block – G, New Alipore, Kolkata – 700 053, West Bengal, India
Mehul Mohanka <i>Managing Director and Group CEO</i>	00052134	146, Block – G, New Alipore, Kolkata – 700 053, West Bengal, India
Syed Yaver Imam* <i>Executive Director</i>	00588381	9, Sambhu Babu Lane, Merlin Regent, 3 <sup>rd</sup> floor, FL-3C, Entally, Kolkata – 700 014, West Bengal, India
Hemant Madhusudan Nerurkar <i>Independent Director</i>	00265887	1201, Lodha Grandeur, Rahimatullah Sayanti Road, Prabhadevi, Mumbai – 400 025, Maharashtra, India
Jagdishwar Prasad Sinha <i>Independent Director</i>	02345086	A4-263, Sobha Onyx, Near Agara Junction, Sarjapur Road, Bangalore - 560 102, Karnataka, India
Madhu Dubhashi <i>Independent Director</i>	00036846	B29, Gate No. 3, Abhimanshree Society, NCL Pashan Road, Pune 411 008, Maharashtra, India

Name and Designation	DIN	Address
Rudolph Michael Edge <i>Independent Director</i>	00626151	Crystal Cove, Flat 11, 59 Satyadev Avenue, MRC Nagar, Chennai – 600 028, Tamil Nadu, India

*\*Syed Yaver Imam, who was designated as an Executive Director for the period from July 19, 2005 to May 31, 2019 and is currently an Executive Director on our Board, has in the past been designated as a Non-executive director on our Board from June 1, 2019 to March 31, 2021. Our Board has redesignated him as an Executive Director with effect from April 1, 2021, in accordance with applicable law.*

For further information on our Directors, see “**Our Management**” beginning on page 180.

### **Company Secretary and Compliance Officer**

Sudipta Bhowal is our Company Secretary and Compliance Officer. His contact details are as follows:

147, Block-G  
New Alipore  
Kolkata 700 053  
West Bengal, India  
Tel: +91 33 3001 9000  
**E-mail:** compliance.officer@tegaindustries.com

### **Book Running Lead Managers**

#### **Axis Capital Limited**

1<sup>st</sup> Floor, Axis House  
C-2, Wadia International Centre  
P. B. Marg, Worli  
Mumbai 400 025  
Maharashtra, India  
**Tel:** +91 22 4325 2183  
**E-mail:** tega.ipo@axiscap.in  
**Website:** www.axiscapital.co.in  
**Investor grievance E-mail:** complaints@axiscap.in  
**Contact Person:** Pratik Pednekar  
**SEBI Registration No:** INM000012029

#### **JM Financial Limited**

7<sup>th</sup> Floor, Cnergy  
Appasaheb Marathe Marg, Prabhadevi  
Mumbai 400 025  
Maharashtra, India  
**Tel:** + 91 22 6630 3030  
**E-mail:** tega.ipo@jmfl.com  
**Website:** www.jmfl.com  
**Investor grievance E-mail:** grievance.ibd@jmfl.com  
**Contact Person:** Prachee Dhuri  
**SEBI Registration No.:** INM000010361

### **Statement of *inter se* allocation of responsibilities among the BRLMs**

The responsibilities and co-ordination by the BRLMs for various activities in this Offer are as follows:

S. No	Activity	Responsibility	Co-ordination
1.	Capital structuring with the relative components and formalities such as type of instruments, size of issue, allocation between primary and secondary, etc. Due diligence of our Company’s operations/management/business /legal etc., Drafting and design of this Draft Red Herring Prospectus, the Red Herring Prospectus and Prospectus, abridged prospectus and application form. The BRLMs shall ensure compliance and completion of prescribed formalities with the Stock Exchanges, SEBI and RoC including finalisation of the Red Herring Prospectus, Prospectus and RoC filing, follow up and coordination till final approval from all regulatory authorities	Axis and JM Financial	Axis

S. No	Activity	Responsibility	Co-ordination
2.	Drafting and approval of statutory advertisement	Axis and JM Financial	Axis
3.	Drafting and approval of all publicity material other than statutory advertisements including corporate advertisements, brochures, filing of media compliance report with SEBI, etc.	Axis and JM Financial	JM Financial
4.	Appointment of Registrar to the Offer, Printer to the Offer, and Advertising Agency (including coordination for their agreements )	Axis and JM Financial	Axis
5.	Appointment of all other intermediaries and including co-ordination for all other agreements	Axis and JM Financial	JM Financial
6.	Preparation of road show presentation and FAQs for the road show team	Axis and JM Financial	JM Financial
7.	International institutional marketing of the Offer, which will cover, <i>inter alia</i> : <ul style="list-style-type: none"> <li>• International Institutional marketing strategy;</li> <li>• Finalizing the list and division of international investors for one-to-one meetings; and</li> <li>• Finalizing international road show and investor meeting schedule.</li> </ul>	Axis and JM Financial	JM Financial
8.	Domestic institutional marketing of the Offer, which will cover, <i>inter alia</i> : <ul style="list-style-type: none"> <li>• Domestic Institutional marketing strategy;</li> <li>• Finalizing the list and division of domestic investors for one-to-one meetings; and</li> <li>• Finalizing domestic road show and investor meeting schedule.</li> </ul>	Axis and JM Financial	Axis
9.	Conduct non-institutional marketing of the Issue, which will cover, <i>inter alia</i> : <ul style="list-style-type: none"> <li>• Finalising media, marketing and public relations strategy;</li> <li>• Formulating strategies for marketing to Non - Institutional Investors</li> </ul>	Axis and JM Financial	Axis
10.	Conduct retail marketing of the Issue, which will cover, <i>inter-alia</i> : <ul style="list-style-type: none"> <li>• Finalising media, marketing, public relations strategy and publicity budget including list of frequently asked questions at retail road shows</li> <li>• Finalising collection centres</li> <li>• Finalising application form</li> <li>• Finalising centres for holding conferences for brokers etc.</li> <li>• Follow - up on distribution of publicity and Issue material including form, RHP/Prospectus and deciding on the quantum of the Issue material</li> </ul>	Axis and JM Financial	JM Financial
11.	Managing anchor book related activities, coordination with Stock Exchanges for anchor intimation, submission of letters regulators post completion of anchor allocation, book building software, bidding terminals and mock trading, payment of 1% security deposit to the designated stock exchange.	Axis and JM Financial	JM Financial
12.	Managing the book and finalization of pricing in consultation with our Company	Axis and JM Financial	Axis
13.	Post bidding activities including management of escrows accounts, coordinate non-institutional allocation, coordination with Registrar, SCSBs and Bankers to the Offer, intimation of allocation and dispatch of refund to Bidders, etc.	Axis and JM Financial	JM Financial

Post-Offer activities, which shall involve essential follow-up steps including allocation to Anchor Investors, follow-up with Bankers to the Offer and SCSBs to get quick estimates of collection and advising the Issuer about the closure of the Offer, based on correct figures, finalisation of the basis of allotment or weeding out of multiple applications, listing of instruments, dispatch of certificates or demat credit and refunds and coordination with various agencies connected with the post-Offer activity such as registrar to the Offer, Bankers to the Offer, SCSBs including responsibility for underwriting arrangements, as applicable.

S. No	Activity	Responsibility	Co-ordination
	Payment of the applicable securities transactions tax on sale of unlisted equity shares by the Selling Shareholders under the Offer for Sale to the Government and filing of the securities transactions tax return by the prescribed due date as per Chapter VII of Finance(No. 2) Act, 2004.		
	Co-ordination with SEBI and Stock Exchanges for refund of 1% security deposit and submission of all post Offer reports including the initial and final post Offer report to SEBI.		

### Syndicate Member

#### JM Financial Services Limited

Ground Floor, 2, 3 & 4, Kamanwala Chambers

Sir PM Road, Fort

Mumbai 400 001

Maharashtra, India

**Tel:** +91 022 6136 3400

**Email:** tn.kumar@jmfl.com/sona.verghese@jmfl.com

**SEBI Registration Number:** INZ000195834

**Website:** www.jmfinancialservices.in

**Contact Person:** T N Kumar/ Sona Verghese

### Legal Counsel to the Company and the Selling Shareholders as to Indian Law

#### Shardul Amarchand Mangaldas & Co

24<sup>th</sup> Floor, Express Towers

Nariman Point

Mumbai 400 021

Maharashtra, India

**Tel:** (91 22) 4933 5555

### Legal Counsel to the BRLMs as to Indian Law

#### IndusLaw

2nd Floor, Block D

The MIRA, Mathura Road

New Delhi 110 065

India

and

#107, 1st Floor, Mistry Mansion

M. G. Road, Fort

Mumbai – 400001, India

**Tel:** +91-22-40074400

### Registrar to the Offer

#### Link Intime India Private Limited

C-101, 1<sup>st</sup> Floor, 247 Park

L.B.S. Marg, Vikhroli West,

Mumbai 400 083

Maharashtra, India

**Tel:** +91 22 4918 6200

**E-mail:** tega.ipo@linkintime.co.in

**Investor Grievance E-mail:** tega.ipo@linkintime.co.in

**Website:** www.linkintime.co.in



**Contact Person:** Shanti Gopalkrishnan  
**SEBI Registration No.:** INR000004058

#### **Escrow Collection Bank/ Public Offer Account Bank/ Refund Bank/ Sponsor Bank**

##### **ICICI Bank Limited**

Capital Market Division, 1<sup>st</sup> Floor  
122, Mistry Bhavan, Dinshaw Vachha Road  
Backbay Reclamation, Churchgate  
Mumbai 400 020, Maharashtra

**Tel:** 022-66818911/ 23/ 24

**E-mail:** sagar.welekar@icicibank.com

**SEBI Registration Number:** INBI00000004

**Website:** www.icicibank.com

**Contact Person:** Sagar Welekar

##### **Self Certified Syndicate Banks**

The list of SCSBs is available at [www.sebi.gov.in/sebiweb/other/OtherAction.do?doRecognised=yes](http://www.sebi.gov.in/sebiweb/other/OtherAction.do?doRecognised=yes) on the SEBI website, or at such other website as may be prescribed by SEBI from time to time. A list of the Designated Branches of the SCSBs with which a Bidder (other than an Anchor Investor), not Bidding through Syndicate/Sub Syndicate or through a Registered Broker, RTA or CDP may submit the Bid cum Application Forms is available at [www.sebi.gov.in/sebiweb/other/OtherAction.do?doRecognised=yes](http://www.sebi.gov.in/sebiweb/other/OtherAction.do?doRecognised=yes) on the SEBI website, and at such other websites as may be prescribed by SEBI from time to time.

##### **Syndicate SCSB Branches**

In relation to Bids (other than Bids by Anchor Investor) submitted to a member of the Syndicate, the list of branches of the SCSBs at the Specified Locations named by the respective SCSBs to receive deposits of Bid cum Application Forms from the members of the Syndicate is available on the website of the SEBI ([www.sebi.gov.in/sebiweb/other/OtherAction.do?doRecognised=yes](http://www.sebi.gov.in/sebiweb/other/OtherAction.do?doRecognised=yes)) and updated from time to time. For more information on such branches collecting Bid cum Application Forms from the Syndicate at Specified Locations, see the website of the SEBI ([www.sebi.gov.in/sebiweb/other/OtherAction.do?doRecognised=yes](http://www.sebi.gov.in/sebiweb/other/OtherAction.do?doRecognised=yes)).

##### **Registered Brokers**

The list of the Registered Brokers eligible to accept ASBA forms, including details such as postal address, telephone number and e-mail address, is provided on the websites of the Stock Exchanges at [www.bseindia.com](http://www.bseindia.com) and [www.nseindia.com](http://www.nseindia.com), as updated from time to time.

##### **Registrar and Share Transfer Agents**

The list of the RTAs eligible to accept ASBA Forms at the Designated RTA Locations, including details such as address, telephone number and e-mail address, is provided on the websites of the Stock Exchanges at [www.bseindia.com/Static/Markets/PublicIssues/RtaDp.aspx?](http://www.bseindia.com/Static/Markets/PublicIssues/RtaDp.aspx?) and [www.nseindia.com/products/content/equities/ipos/asba\\_procedures.htm](http://www.nseindia.com/products/content/equities/ipos/asba_procedures.htm) respectively, as updated from time to time.

##### **Collecting Depository Participants**

The list of the CDPs eligible to accept ASBA Forms at the Designated CDP Locations, including details such as their name and contact details, is provided on the websites of the Stock Exchanges at [www.bseindia.com/Static/Markets/PublicIssues/RtaDp.aspx?](http://www.bseindia.com/Static/Markets/PublicIssues/RtaDp.aspx?) and [www.nseindia.com/products/content/equities/ipos/asba\\_procedures.htm](http://www.nseindia.com/products/content/equities/ipos/asba_procedures.htm), respectively, as updated from time to time.

##### **Statutory Auditors of our Company**

###### **Price Waterhouse & Co Bangalore LLP**

Plot Nos. 56 & 57, Block DN-57, Sector-V,  
Salt Lake Electronics Complex  
Kolkata, West Bengal 700 091, India

**Tel:** +91 (33) 4400 1111  
**E-mail:** avijit.mukerji@pwc.com  
**ICAI Registration Number:** 007567S/S200012  
**Peer Review Number:** 013181

#### **Bankers to our Company**

##### **RBL Bank Limited**

4A Camac Street  
PS Arcadia Central  
7<sup>th</sup> Floor  
Kolkata- 700016, India  
**Tel:** 033-23014719  
**E-mail:** kapil.chandak@rblbank.com  
**Website:** www.rblbank.com  
**Contact person:** Kapil Chandak

##### **Standard Chartered Bank**

19, Netaji Subhash Road  
Kolkata- 700001, India  
**Tel:** 033-39120227  
**E-mail:** Sanjeev.jain@sc.com  
**Website:** www.sc.com  
**Contact person:** Sanjeev Jain

##### **Axis Bank Limited**

1, Shakespeare Sarani  
Kolkata- 700071, India  
**Tel:** 033-6704400/ 9819897491  
**E-mail:** mayank.bhuwania@axisbank.com/ cbbkolkata.operationshead@axisbank.com  
**Website:** www.axisbank.com  
**Contact person:** Mayank Bhuwania

##### **Citi Bank N.A.**

Kanak Building, 41,  
Chowringhee Road,  
Kolkata – 700071, India  
**Tel:** 033-44003466  
**E-mail:** anurag.modi@citi.com  
**Website:** www.citigroup.net  
**Contact person:** Anurag Modi

##### **ICICI Bank Limited**

3A, Gurusaday Road,  
Rowland Road, Ballygunge,  
Kolkata – 700019, India  
**Tel:** 91-98311-40008  
**Email:** nishith.saraogi@icicibank.com  
**Website:** www.icicibank.com  
**Contact person:** Nishith Saraogi

##### **ICICI Bank UK PLC**

One Thomas More Square  
E1W1YN, PO Box 68921  
**Tel:** 91-20347-85319  
**Email:** vikash.mehta@icicibank.com  
**Website:** www.icicibank.co.uk  
**Contact person:** Vikash Mehta  
**Company Number:** 04663024

**Grading of the Offer**

No credit agency registered with SEBI has been appointed in respect of obtaining grading for the Offer.

**Appraising Entity**

None of the objects for which the Net Proceeds will be utilized has been appraised by any agency.

**Monitoring Agency**

As the Offer is through an Offer for Sale of Equity Shares, our Company is not required to appoint a monitoring agency for this Offer.

**Credit Rating**

As the Offer is of Equity Shares, credit rating is not required.

**Trustees**

As the Offer is of Equity Shares, the appointment of trustees is not required.

**Changes in auditors**

There have been no changes in the auditors of our Company during the three years preceding the date of this Red Herring Prospectus.

**Green Shoe Option**

No green shoe option is contemplated under the Offer.

**Filing**

A copy of the Draft Red Herring Prospectus has been filed electronically on the SEBI's online portal and at [cfddil@sebi.gov.in](mailto:cfddil@sebi.gov.in), in accordance with the instructions issued by SEBI on March 27, 2020, in relation to "Easing of Operational Procedure –Division of Issues and Listing –CFD" and has also been filed with Securities and Exchange Board of India Eastern Regional Office at L&T Chambers, 3<sup>rd</sup> Floor, 16 Camac Street, Kolkata - 700017, West Bengal, India.

A copy of this Red Herring Prospectus, along with the documents required to be filed, will be delivered for filing to the RoC in accordance with Section 32 of the Companies Act 2013, and a copy of the Prospectus required to be filed under Section 26 of the Companies Act 2013 will be delivered for filing to the RoC situated at the address mentioned below:

**Registrar of Companies**

Nizam Palace  
2<sup>nd</sup> MSO Building  
2<sup>nd</sup> floor, 234/4, A.J.C.B. Road  
Kolkata 700 020  
West Bengal, India

**Expert to the Offer**

Except as disclosed below, our Company has not obtained any expert opinions:

Our Company has received written consent dated November 23, 2021 from Price Waterhouse & Co Bangalore LLP to include their name as required under section 26 (5) of the Companies Act, 2013 read with SEBI ICDR Regulations, in this Red Herring Prospectus and as an "expert" as defined under section 2(38) of the Companies Act, 2013 to the extent and in their capacity as our Statutory Auditors, and in respect of their examination report, dated November 10, 2021 on our Restated Consolidated Financial Information in this Red Herring Prospectus and such consent has not been withdrawn as on the date of this Red Herring Prospectus. However, the term "expert" shall not be construed to mean an "expert" as defined under the U.S. Securities Act.

## Book Building Process

Book building, in the context of the Offer, refers to the process of collection of Bids from investors on the basis of the Red Herring Prospectus and the Bid cum Application Forms and the Revision Forms within the Price Band, which will be decided by our Company and the Selling Shareholders, in consultation with the BRLMs and advertised in all editions of Financial Express (a widely circulated English national daily newspaper), all editions of Jansatta (a widely circulated Hindi national daily newspaper) and all editions of Arthik Lipi (a widely circulated Bengali regional daily newspaper, Bengali being the regional language in West Bengal, where our Registered Office is located), at least two Working Days prior to the Bid/Offer Opening Date and shall be made available to the Stock Exchanges for the purposes of uploading on their respective websites. The Offer Price shall be determined by our Company and the Selling Shareholders, in consultation with the BRLMs after the Bid/Offer Closing Date. For details, see “*Offer Procedure*” beginning on page 380.

**All Bidders, except Anchor Investors, are mandatorily required to use the ASBA process for participating in the Offer by providing details of their respective ASBA Account in which the corresponding Bid Amount will be blocked by SCSBs. In addition to this, the Retail Individual Investors may participate through the ASBA process by either (a) providing the details of their respective ASBA Account in which the corresponding Bid Amount will be blocked by SCSBs; or (b) through the UPI Mechanism. Anchor Investors are not permitted to participate in the Offer through the ASBA process.**

**In accordance with the SEBI ICDR Regulations, QIBs and Non-Institutional Investors are not allowed to withdraw or lower the size of their Bids (in terms of the quantity of the Equity Shares or the Bid Amount) at any stage. Retail Individual Investors (subject to the Bid Amount being up to ₹ 200,000) can revise their Bids during the Bid/Offer Period and withdraw their Bids on or before the Bid/Offer Closing Date. Further, Anchor Investors cannot withdraw their Bids after the Anchor Investor Bid/ Offer Period. Allocation to the Anchor Investors will be on a discretionary basis.**

For further details on the method and procedure for Bidding and book building procedure, see “*Offer Structure*” and “*Offer Procedure*” beginning on pages 377 and 380, respectively.

**The Book Building Process under the SEBI ICDR Regulations and the Bidding process are subject to change from time to time. Investors are advised to make their own judgment about an investment through this process prior to submitting a Bid.**

Investors should note the Offer is also subject to: (i) obtaining final listing and trading approvals of the Stock Exchanges, which our Company shall apply for after Allotment; and (ii) filing of the Prospectus with the RoC.

## Underwriting Agreement

After the determination of the Offer Price and allocation of Equity Shares but prior to the filing of the Prospectus with the RoC, our Company and the Selling Shareholders will enter into an Underwriting Agreement with the Underwriters for the Equity Shares proposed to be offered/issued through the Offer. It is proposed that pursuant to the terms of the Underwriting Agreement, each of the BRLMs will be severally responsible for bringing in the amount devolved, in the event any of their respective Syndicate Members do not fulfill their underwriting obligations. Pursuant to the terms of the Underwriting Agreement, the obligations of the Underwriters will be several and will be subject to certain conditions to closing, as specified therein.

The Underwriting Agreement is dated [•]. The Underwriters have indicated their intention to underwrite the following number of Equity Shares:

*(This portion has been intentionally left blank and will be filled in before filing of the Prospectus with the RoC)*

Name, address, telephone, facsimile and e-mail of the Underwriters	Indicative Number of Equity Shares to be Underwritten	Amount Underwritten (in ₹ million)
[•]	[•]	[•]
[•]	[•]	[•]
[•]	[•]	[•]

The abovementioned amounts are provided for indicative purposes only and would be finalized after the pricing and actual allocation and subject to the provisions of the SEBI ICDR Regulations.

In the opinion of our Board of Directors (based on representations made to our Company by the Underwriters), the resources of the Underwriters are sufficient to enable them to discharge their respective underwriting obligations in full. The Underwriters are registered with SEBI under Section 12(1) of the SEBI Act or registered as brokers with the Stock Exchange(s). Our Board of Directors, at its meeting held on [•], has accepted and entered into the Underwriting Agreement mentioned above on behalf of our Company.

Allocation among the Underwriters may not necessarily be in proportion to their underwriting commitments set forth in the table above. Notwithstanding the above table, the Underwriters shall be severally responsible for ensuring payment with respect to Equity Shares allocated to investors procured by them. In the event of any default in payment, the respective Underwriter, in addition to other obligations defined in the Underwriting Agreement, will also be required to procure subscriptions for/subscribe to Equity Shares to the extent of the defaulted amount in accordance with the Underwriting Agreement.

The Underwriting Agreement has not been executed as on the date of this Red Herring Prospectus and our Company and the Selling Shareholders intend to enter into an Underwriting Agreement with the Underwriters after the determination of the Offer Price and allocation of Equity Shares, but prior to filing the Prospectus with the RoC.

## CAPITAL STRUCTURE

The share capital of our Company, as of the date of this Red Herring Prospectus, is set forth below:

Particulars	Aggregate nominal value (in ₹ million)	Aggregate value at Offer Price*
<b>A) AUTHORIZED SHARE CAPITAL<sup>(1)</sup></b>		
70,000,000 Equity Shares of face value of ₹ 10 each	700	-
25,000,000 Redeemable Preference Shares of face value of ₹ 10 each	250	-
10,000,000 CCPP of face value of ₹ 10 each	100	-
<b>ISSUED, SUBSCRIBED AND PAID-UP SHARE CAPITAL BEFORE THE OFFER</b>		
66,293,149 Equity Shares of face value of ₹ 10 each	662.93	[•]
<b>C) PRESENT OFFER IN TERMS OF THIS RED HERRING PROSPECTUS</b>		
Offer of up to 13,669,478 Equity Shares of face value of ₹10 each <sup>(2) (3) (4)</sup>	[•]	[•]
<b>D) ISSUED, SUBSCRIBED AND PAID-UP SHARE CAPITAL AFTER THE OFFER</b>		
66,293,149 Equity Shares of face value of ₹ 10 each	662.93	[•]
<b>E) SECURITIES PREMIUM ACCOUNT</b>		
Before (as on the date of this Red Herring Prospectus) and after the Offer		₹ 902.10 million

\*To be updated after finalization of the Offer Price.

- (1) For details in relation to changes in the authorized share capital of our Company, see “History and Certain Corporate Matters – Amendments to the Memorandum of Association” on page 171.
- (2) The Offer has been authorized by a resolution of our Board dated April 30, 2021. Further, our Board has taken on record the approval for the Offer for Sale by the Selling Shareholders pursuant to its resolution dated August 16, 2021.
- (3) The Selling Shareholders have confirmed and authorized their respective participation in the Offer for Sale. The Equity Shares being offered by each of the Selling Shareholders have been held by such Selling Shareholder for a period of at least one year prior to the date of filing of the Draft Red Herring Prospectus in accordance with the SEBI ICDR Regulations and accordingly, are eligible for the Offer in accordance with the provisions of the SEBI ICDR Regulations and confirms that its respective Offered Shares (arising upon conversion of the respective CCPP held by it) will be eligible to be offered for sale in the Offer in terms of the SEBI ICDR Regulations. For details, see “The Offer” and “Other Regulatory and Statutory Disclosures” on pages 64 and 362, respectively.

### Notes to Capital Structure

#### 1. Share Capital History

##### a. Equity share capital history of our Company

The following table sets forth the history of the equity share capital of our Company:

Date of allotment	Reason / Nature of allotment	No. of equity shares allotted	Face value per equity share (₹)	Issue price per equity share (₹)	Nature of consideration
May 24, 1976	Subscription to the Memorandum of Association <sup>(1)</sup>	7	10	10	Cash
February 17, 1977	Further issue <sup>(2) *</sup>	50,000	10	10	Cash
March 14, 1977	Rights issue <sup>(3) *</sup>	52,500	10	10	Cash
March 28, 1977	Rights issue <sup>(4) *</sup>	33,500	10	10	Cash
April 28, 1977	Rights issue <sup>(5) *</sup>	43,500	10	10	Cash
July 6, 1977	Further issue <sup>(6) *</sup>	20,430	10	10	Cash
July 27, 1977	Rights issue <sup>(7) *</sup>	63	10	10	Cash
September 28, 1977	Further Issue <sup>(8) *</sup>	150,000	10	10	Cash
October 4, 1977	Further issue <sup>(9) *</sup>	150,000	10	10	Cash
July 21, 1980	Rights issue <sup>(10) *</sup>	89,000	10	10	Cash
January 6, 1981	Further issue <sup>(11) *</sup>	11,000	10	10	Cash
September 17, 1990	Further issue <sup>(12) *</sup>	400,000	10	20.50	Cash
December 7, 2001	Further issue <sup>(13) *</sup>	250,000	10	10	Cash
March 1, 2002	Further issue <sup>(14) *</sup>	250,000	10	10	Cash
September 2, 2002	Cancellation of shares <sup>(15)</sup>	(401,000)	10	N.A.	N.A.

Date of allotment	Reason / Nature of allotment	No. of equity shares allotted	Face value per equity share (₹)	Issue price per equity share (₹)	Nature of consideration
September 2, 2002	Scheme of amalgamation <sup>(16)*</sup>	651,734	10	N.A.	Other than cash
March 31, 2003	Rights issue <sup>(17)*</sup>	875,362	10	10	Cash
March 27, 2004	Rights issue <sup>(18)*</sup>	787,824	10	10	Cash
September 30, 2004	Rights issue <sup>(19)*</sup>	341,389	10	10	Cash
March 22, 2005	Rights issue <sup>(20)</sup>	375,527	10	10	Cash
August 7 2007	Further issue <sup>(21)</sup>	300,000	10	65	Cash
October 5, 2013	Bonus issuance in the ratio of 12:1 <sup>(22)</sup>	53,170,032	10	N.A.	N.A.
November 10, 2021	Conversion of CCPP in the ratio of 1:1 <sup>(23)</sup>	8,692,281	10	N.A.	N.A.

\*The resolution(s) passed by our Board and/or Shareholders and/or Form 2 filed in relation to such allotment of Equity Shares of our Company are untraceable and consequently, we are unable to ascertain certain details about such allotments, including the nature of allotment, nature of consideration and issue price per Equity Share. Our Company has, through letters dated July 5, 2021 and September 27, 2021, preferred two right to information applications before the Public Information Officer, Registrar of Companies, West Bengal requesting the authorities to provide all the Form 2 filings and the certified copies of documents available with the RoC in relation to our Company since its inception. Further, Aditya Tiwari & Company, Practising Company Secretary, has conducted an independent search at the RoC office and submitted a report dated July 14, 2021 to extract the Company's form filings. For details, see "Risk Factors- We have been unable to locate certain of our historical corporate records." on page 31.

- (1) One Equity Share each allotted to Madan Mohan Mohanka, Framroze Ruttonji Bhesania, Tara Chand Mohanka, Manoj Basu, Nanda Kishore Varma, Partha Sarathi Roy and Tattamangalam Vaidyanathan Sivarama Krishnan
- (2) 50,000 Equity Shares were allotted to Techno Electric & Engg. Corporation Limited
- (3) 5,500 Equity Shares were allotted to Madan Mohanka HUF, 6,000 Equity Shares were allotted to Tara Chand Mohanka, 2,000 Equity Shares were allotted to Durga Dutt Mohanka, 3,000 Equity Shares were allotted to Savitri Devi, 10,000 Equity Shares were allotted to Madan Mohan Mohanka and Tara Chand Mohanka as the trustee of Lalit Kumar and Manoj Kumar and 26,000 Equity Shares were allotted to Primax Investments Private Limited
- (4) 3,400 Equity Shares were allotted to Manju Mohanka, 4,800 Equity Shares were allotted to Sohanlal Mohanka, 6,000 Equity Shares were allotted to Madan Mohan Mohanka, 3,000 Equity Shares were allotted to Durga Dutt Mohanka & Ors HUF, 1,800 Equity Shares were allotted to Savitri Devi Mohanka, 14,000 Equity Shares were allotted to Primax Investments Private Limited and 500 Equity Shares were allotted to Framroze Ruttonji Bhesania
- (5) 20,000 Equity Shares allotted to Primax Investments Private Limited, 5,000 Equity Shares were allotted to Techno Pipeworks Engg. Corporation (I) Private Limited, 500 Equity Shares were allotted to Manjari Sahi, 500 Equity Shares were allotted to Suresh Chandra Soni and Shanta Soni, 300 Equity Shares were allotted to Manoj Basu, 250 Equity Shares were allotted to Binod Kumar Shah, 500 Equity Shares allotted to S. Mohan, 500 Equity Shares were allotted to S. Mukanden, 500 Equity Shares were allotted to N. Doraiswamy, 500 Equity Shares were allotted to Saroja Doraiswamy, 500 Equity Shares were allotted to Bragathkujam, 500 Equity Shares were allotted to Chandrika Mahalingam, 250 Equity Shares were allotted to Gautam Ghosh, 200 Equity Shares were allotted to Jeboo Dara Antia & Dara Pirojshaw Antia, 5,000 Equity Shares were allotted to Electro Zavod (I) Private Limited, 6,000 Equity Shares were allotted to Primax Investments Private Limited, 2,000 Equity Shares were allotted to Purushottam Mall and 500 Equity Shares were allotted to Shanta Soni and Suresh Chandra Soni.
- (6) 100 Equity Shares were allotted to Jeboo Dara Antia & Dara Pirojshaw Antia, 200 Equity Shares were allotted to Ajit Kaur Bassi & Inder Jit Singh Bassi, 100 Equity Shares were allotted to Damodar Ropeways & Const Corporation Private Limited, 200 Equity Shares were allotted to Uma Nath Sadhu, 200 Equity Shares were allotted to Amar Nath Sadhu, 500 Equity Shares were allotted to Ram Bujhawan Sinha and Yashovardhan Sinha, 500 Equity Shares were allotted to Prasanto Kumar Mukherjee and Puspika Mukherjee, 50 Equity Shares were allotted to Nalini Bhattacharyya, 50 Equity Shares were allotted to Nirmal Devi, 50 Equity Shares were allotted to Ram Adhar Mishra, 50 Equity Shares were allotted to K.E. Oonnoonney, 50 Equity Shares were allotted to Nairit Kumar Mukherjee, 50 Equity Shares were allotted to Ganga Narayan Sinha, 100 Equity Shares were allotted to Chandrambath Srinivasan and Usha Srinivasan, 50 Equity Shares were allotted to Chand Kumar Kaul, 50 Equity Shares were allotted to Swapan Kumar Sarkar, 50 Equity Shares were allotted to K. Venu Gopalan, 50 Equity Shares were allotted to Subhasish Mukherjee, 50 Equity Shares were allotted to Susobhan Dasgupta, 100 Equity Shares were allotted to Niranjan Sasmal and Chhaya Sasmal, 100 Equity Shares were allotted to Rabikar Chatterjee, 100 Equity Shares were allotted to Ratan Mani Dutta, 200 Equity Shares were allotted to Partha Sarathi Roy, 50 Equity Shares were allotted to Indrani Dasgupta, 50 Equity Shares were allotted to Pushpa M. Pherwani, 50 Equity Shares were allotted to Kaberi Roy, 500 Equity Shares were allotted to V. Krishnan and Usha Krishnan, 50 Equity Shares were allotted to Gobind Charan Gaya, 100 Equity Shares were allotted to Sachidanandam Shista, 50 Equity Shares were allotted to Mumtaz Alam, 50 Equity Shares were allotted to Manohar Khachane, 100 Equity Shares were allotted to Manik Chandra Mandal, 50 Equity Shares were allotted to Shanti Lal Mathur, 50 Equity Shares were allotted to Asis Kumar Roy Chaudhuri, 200 Equity Shares were allotted to N.R. Ramachandran, 50 Equity Shares were allotted to Asok Kumar Tewari and Subithi Tewari, 50 Equity Shares were allotted to Kalidas Bhattacharjee and Gita Bhattacharjee, 50 Equity Shares were allotted to Namita Das, 200 Equity Shares were allotted to Deva Priya Sen, 2,600 Equity Shares were allotted to Padam Parkash Gupta, 300 Equity Shares were allotted to Mahendra Kumar Mittal, 50 Equity Shares were allotted to Sujal Kumar Ghosh, 300 Equity Shares were allotted to Pravin Kumar, 50 Equity Shares were allotted to Alka Kapur, 500 Equity Shares were allotted to Vishva Rattan Sud, 100 Equity Shares were allotted to L.R.M. Nathan and N. Nathan, 5,000 Equity Shares were allotted to Techno Pipeworks Engg. Corporation (I) Private Limited, 50 Equity Shares were allotted to Niranjan Chakraborty, 100 Equity Shares were allotted to Atish Ratan Dasgupta, 250 Equity Shares were allotted to Shapur Jamshed Dalal, 250 Equity Shares were allotted to Aparajita Basu, 250 Equity Shares were allotted to Amarendra Nath Basu, 250 Equity Shares were allotted to Usha Basu,

- 250 Equity Shares were allotted to Mita Ghosh, 500 Equity Shares were allotted to Shibani Iyengar 400 Equity Shares were allotted to Rajan Sapra, 500 Equity Shares were allotted to Raja Shah, 200 Equity Shares were allotted to Ram Dhan Sharma, 5,130 Equity Shares were allotted to Deluxe Investment & Agencies Private Limited, 100 Equity Shares were allotted to Urmila Sodhani, 500 Equity Shares were allotted to Prabha Agarwal, 500 Equity Shares were allotted to Ratan Lal Agarwal and 50 Equity Shares were allotted to Sibananda Majumdar
- (7) 63 Equity Shares were allotted to Manoj Basu
- (8) 55,000 Equity Shares were allotted to West Bengal Industrial Development Corporation Limited, 70,000 Equity Shares were allotted to Industrial Credit and Investment Corporation of India Limited and 25,000 Equity Shares were allotted to State Bank of India
- (9) 100,000 Equity Shares were allotted to Industrial Development Bank of India and 50,000 Equity Shares were allotted to Industrial Finance Corporation of India
- (10) 10,000 Equity Shares were allotted to Industrial Finance Corporation of India, 20,000 Equity Shares were allotted to Industrial Development Bank of India, 14,000 Equity Shares were allotted to Industrial Credit and Investment Corporation of India Limited, 5,000 Equity Shares were allotted to State Bank of India, 10,400 Equity Shares were allotted to Madan Mohan Mohanka, 12,500 Equity Shares were allotted to Tara Chand Mohanka, 13,000 Equity Shares were allotted to Primax Investments Private Limited, 500 Equity Shares were allotted to Manoj Basu, 500 Equity Shares were allotted to Manju Mohanka, 500 Equity Shares were allotted to Deva Priya Sen, 2,000 Equity Shares were allotted to Deluxe Investment & Agencies Private Limited, 200 Equity Shares were allotted to N.R. Ramachandran, 200 Equity Shares were allotted to M.K. Mittal and 200 Equity Shares were allotted to R. Sapra
- (11) 11,000 Equity Shares were allotted to West Bengal Industrial Development Corporation Limited
- (12) 400,000 Equity Shares were allotted to Skega Aktiebolag
- (13) 250,000 Equity Shares were allotted to TPW Engineering Private Limited
- (14) 250,000 Equity Shares were allotted to TPW Engineering Private Limited
- (15) 401,000 Equity Shares were cancelled by our Company pursuant to the resolution dated September 2, 2002 approved by our Board
- (16) Allotment of 867 Equity Shares to Ashok Gupta, 304,200 Equity Shares to Mehul Mohanka and 346,667 Equity Shares to Manish Mohanka as shareholders of the erstwhile MM Global Private Limited (“MMGPL”), pursuant to the scheme of amalgamation of MMGPL with our Company, which was approved by the High Court of Kolkata by its order dated April 19, 2002
- (17) 109,049 Equity Shares were allotted to Deluxe Investment & Agencies Private Limited, 409,136 Equity Shares were allotted to Monarch Systems (I) Private Limited, 277,177 Equity Shares were allotted to TPW Engineering Private Limited and 80,000 Equity Shares were issued to Spencer Business Private Limited
- (18) 249,293 Equity Shares were allotted to TPW Engineering Private Limited, 315,351 Equity Shares were issued to Spencer Business Private Limited, 97,845 Equity Shares were allotted to Deluxe Investment & Agencies Private Limited, 100,000 Equity Shares were issued to Monarch Systems (I) Private Limited and 25,335 Equity Shares were issued to Madan Mohan Mohanka as karta of Madan Mohan Mohanka HUF
- (19) 9,863 Equity Shares were allotted to Manju Mohanka, 4,895 Equity Shares were allotted to Amar Nath Sadhu, 98,693 Equity Shares were allotted to Madan Mohan Mohanka, as the legal guardian of Manish Mohanka, 97,956 Equity Shares were allotted to Madan Mohan Mohanka in his capacity as the Karta for Madan Mohan Mohanka HUF, 63,669 Equity Shares were allotted to Madan Mohan Mohanka and 66,313 Equity Shares were allotted to Mehul Mohanka
- (20) 44,461 Equity Shares were allotted to Madan Mohan Mohanka in his capacity as the Karta for Madan Mohan Mohanka HUF, 163,084 Equity Shares were allotted to Mehul Mohanka and 167,982 Equity Shares were allotted to Manish Mohanka
- (21) 200,000 Equity Shares were allotted to NFSPL and 100,000 Equity Shares were issued to Marudhar Food & Credit Limited
- (22) Bonus issuance of 53,170,032 Equity Shares in the ratio of 12:1, i.e., for every Equity Share held by an existing shareholder, 12 bonus Equity Shares were issued, consisting of 13,404 Equity Shares to Mehul Mohanka HUF, 944,628 Equity Shares to Madan Mohan Mohanka, 61,140 Equity Shares to Amar Nath Sadhu, 4,800 Equity Shares to N.R. Ramachandran, 3,600 Equity Shares to Pravin Kumar, 7,330,944 Equity Shares to Manish Mohanka, 6,858,120 Equity Shares to Mehul Mohanka, 3,000 Equity Shares to Jeroo Dalal, 33,741,372 Equity Shares to NFSPL, 2,016,024 Equity Shares to Madan Mohan Mohanka (HUF), 1,200,000 Equity Shares to Marudhar Food and Credit Limited, 6,000 Equity Shares each to Mrs. Mucca Framroze Bhesania, S. Mohan, S. Mukandan, T.N. Doraiswami, Saroja Doraiswami, V Krishnan and Usha Krishnan and Raja Shah, 1,200 Equity Shares each to Damodar Ropeways & Construction Corporation Private Limited, Chandrabath Srinivasan and Mrs. Uma Srinivasan, Susobhan Dasgupta, Sachinandan Shista. L.R.M. Nathan and Urmila Sodhani, 2,400 Equity Shares each to Tridib Nath Sadhu, Partha Sarathi Roy and Padam Prakash Gupta, 4,800 Equity Shares to Yashovardhan Sinha and Mahendra Kumar, 600 Equity Shares each to Nalini Ranjan Bhattacharjee, Ram Adhar Mishra, K.E. Oonmooney, Nairit Kumar Mukherjee, Ganga Narayan Sinha, Chand Kumar Kaul, K. Venu Gopalan, Indrani Dasgupta, Kaberi Roy Choudhury, Mumtaz Alam, Manohar Khachane, Shantilal Mathur, Kalidas Bhattacharjee and Gita Bhattacharjee, Nirranjan Chakraborty, and Sibananda Mazumdar, 12 Equity Shares each to F.R. Bhesania and Techno Electric and Engineering Corporation Limited, TC Mohanka and Techno Electric and Engineering Corporation Limited, Manoj Basu and Techno Electric and Engineering Corporation Limited, N.K. Verma and Techno Electric and Engineering Corporation Limited, P.S. Roy and Techno Electric and Engineering Corporation Limited, TVS Krishnan and Techno Electric and Engineering Corporation Limited, Madan Mohan Mohanka and Techno Electric and Engineering Corporation Limited, and 922,716 Equity Shares to Wagner pursuant to capitalisation of Securities Premium Reserve Account and General Reserve Account of our Company, as at March 31, 2013
- (23) 8,692,281 Equity Shares allotted to Wagner Limited pursuant to conversion of 8,692,281 CCPP held by them in the ratio of 1:1, pursuant to resolutions dated November 10, 2021 passed by our Board and Shareholders. For further details, see “- Notes to the Capital Structure – Preference Share capital history of our Company” below.



b. *Preference share capital history of our Company*

The following table sets forth the history of the CCPP of our Company.

Date of allotment	Reason / Nature of allotment	No. of preference shares allotted	Face value per preference share (₹)	Issue price per preference share (₹)	Nature of consideration
May 11, 2011	Preferential allotment <sup>(1)</sup>	668,637	10	2,243.40	Cash
October 5, 2013	Bonus issuance in the ratio of 12:1 <sup>(2)</sup>	8,023,644	10	N.A.	N.A.
November 10, 2021	Conversion to Equity Shares in the ratio of 1:1 <sup>(3)</sup>	(8,692,281)	10	N.A.	N.A.

<sup>(1)</sup> 668,637 CCPP were allotted to Wagner pursuant to Share Subscription and Share Purchase Agreement dated May 11, 2011. For details of the rights in relation to the CCPP, see 'History and other Corporate Matters- Shareholders' Agreements and Other Agreements' on page 172.

<sup>(2)</sup> Bonus issuance of 8,023,644 CCPP to Wagner Limited in the ratio of 12:1, i.e., for every CCPP held, 12 bonus CCPP were issued pursuant to capitalisation of Securities Premium Reserve Account and General Reserve Account of our Company, as at March 31, 2013.

<sup>(3)</sup> The CCPP have been converted into 8,692,281 Equity Shares. For details of the conversion of CCPP to Equity Shares, see "- Notes to Capital Structure – Share Capital History–Equity Share capital history of our Company" above.

2. As on the date of this Red Herring Prospectus, our Company has not issued Equity Shares or CCPP out of revaluation reserves at any time since incorporation.

3. **Issue of Equity Shares under employee stock option schemes**

For details of Equity Shares issued by our Company pursuant to the exercise of options which have been granted under the employee stock option schemes, see "- *Equity Share capital history of our Company*" below.

4. Except as stated below, as on date of this Red Herring Prospectus, our Company has not issued Equity Shares or CCPP for consideration other than cash at any time since incorporation.

Date of allotment	Reason nature of allotment	No. of equity/preference shares allotted	Face value per equity share/preference shares (₹)	Issue price per equity share (₹)	Nature of consideration	Benefits to our Company
September 2, 2002	Scheme of amalgamation <sup>(1)</sup>	651,734	10	N.A.	Other than cash	See " <i>History and Certain Corporate Matters – Details regarding acquisition of business/ undertakings, mergers, amalgamation, revaluation of assets</i> " on page
October 5, 2013	Bonus issuance in the ratio of 12:1 <sup>(2)</sup>	53,170,032	10	N.A.	N.A.	–
	Bonus issuance in the ratio of 12:1 <sup>(3)</sup>	8,023,644	10	N.A.	N.A.	–

<sup>(1)</sup> Allotment of 867 Equity Shares to Ashok Gupta, 304,200 Equity Shares to Mehul Mohanka and 346,667 Equity Shares to Manish Mohanka as shareholders of the erstwhile MM Global Private Limited ("**MMGPL**"), pursuant to the scheme of amalgamation of MMGPL with our Company, which was approved by the High Court of Kolkata by its order dated April 19, 2002

<sup>(2)</sup> Bonus issuance of 53,170,032 Equity Shares in the ratio of 12:1 i.e. for every Equity Share held by an existing shareholder, 12 bonus Equity Shares, consisting of 13,404 Equity Shares to Mehul Mohanka HUF, 944,628 Equity Shares to Madan Mohan Mohanka, 61,140 Equity Shares to Amar Nath Sadhu, 4,800 Equity Shares to N.R. Ramachandran, 3,600 Equity Shares to Pravin Kumar, 7,330,944 Equity Shares to Manish Mohanka, 6,858,120 Equity Shares to Mehul Mohanka, 3,000 Equity Shares to Jeroo Dalal, 33,741,372 Equity Shares to NFSP, 2,016,024 Equity Shares to Madan Mohan Mohanka (HUF), 1,200,000 Equity Shares to Marudhar Food and Credit Limited, 6,000 Equity Shares each to Mrs. Mucca Framroze Bhesania, S. Mohan, S. Mukandan, T.N. Doraiswami, Saroja Doraiswamy, V Krishnan and Usha Krishnan and Raja Shah, 1,200 Equity Shares each to Damodar Ropeways & Construction Corporation Private

Limited, Chandrabath Srinivasan and Mrs. Uma Srinivasan, Susobhan Dasgupta, Sachinandan Shista. L.R.M. Nathan and Urmila Sodhani, 2,400 Equity Shares each to Tridib Nath Sadhu, Partha Sarathi Roy and Padam Prakash Gupta, 4,800 Equity Shares to Yashovardhan Sinha and Mahendra Kumar, 600 Equity Shares each to Nalini Ranjan Bhattacharjee, Ram Adhar Mishra, K.E. Oonnooney, Nairit Kumar Mukherjee, Ganga Narayan Sinha, Chand Kumar Kaul, K. Venu Gopalan, Indrani Dasgupta, Kaberi Roy Choudhury, Mumtaz Alam, Manohar Khachane, Shantilal Mathur, Kalidas Bhattacharjee and Gita Bhattacharjee, Niranjana Chakraborty, and Sibananda Mazumdar, 12 Equity Shares each to F.R. Bhesania and Techno Electric and Engineering Corporation Limited, TC Mohanka and Techno Electric and Engineering Corporation Limited, Manoj Basu and Techno Electric and Engineering Corporation Limited, N.K. Verma and Techno Electric and Engineering Corporation Limited, P.S. Roy and Techno Electric and Engineering Corporation Limited, TVS Krishnan and Techno Electric and Engineering Corporation Limited, Madan Mohan Mohanka and Techno Electric and Engineering Corporation Limited, and 922,716 Equity Shares to Wagner pursuant to capitalisation of Securities Premium Reserve Account and General Reserve Account of our Company, as at March 31, 2013

<sup>(3)</sup> Bonus issuance of 8,023,644 CCPP to Wagner Limited in the ratio of 12:1, i.e., for every CCPP held, 12 bonus CCPP were issued pursuant to capitalisation of Securities Premium Reserve Account and General Reserve Account of our Company, as at March 31, 2013

## 5. Equity shares issued pursuant to scheme of arrangement

Our Company has not allotted any equity shares pursuant to any scheme approved under Sections 391 to 394 of the Companies Act 1956 or Sections 230 to 234 of the Companies Act 2013, except as stated below:

Date of allotment	No. of equity shares allotted	Face value per equity share (₹)	Issue price per equity share (₹)	Benefits to our Company
September 2, 2002	651,734 <sup>(1)</sup>	10	N.A.	See “ <b>Details regarding material acquisitions or divestments of business/undertakings, mergers, amalgamation, revaluation of assets, etc. in the last 10 years</b> ” on page 172

<sup>(1)</sup> Allotment of 867 Equity Shares to Ashok Gupta, 304,200 Equity Shares to Mehul Mohanka and 346,667 Equity Shares to Manish Mohanka as shareholders of the erstwhile MM Global Private Limited (“**MMGPL**”), pursuant to the scheme of amalgamation of MMGPL with our Company, which was approved by the High Court of Kolkata by its order dated April 19, 2002

6. Our Company has not issued Equity Shares in the previous one year immediately preceding the date of the Draft Red Herring Prospectus and this Red Herring Prospectus.
7. Our Company has not issued CCPP in the previous one year immediately preceding the date of this Red Herring Prospectus.

## 8. History of equity share capital build-up, contribution and lock-in of Promoters' shareholding

### (a) Build-up of Promoters' shareholding in our Company

As on the date of this Red Herring Prospectus, our Promoters hold 55,161,483 Equity Shares aggregating to 83.21% of the issued, subscribed and paid-up equity share capital of our Company.

Set forth below is the build-up of the equity shareholding of our Promoters, since incorporation of our Company:

Date of allotment/ transfer/ acquisition of shares	Number of equity shares allotted / transferred	Face value per equity share (₹)	Issue/ Acquisition/ transfer price per equity share (₹)	Nature of consideration	Nature of transaction	Percentage of pre-Offer equity share capital of the Company (%)	Percentage of post-Offer equity share capital of the Company (%)
<b>Madan Mohan Mohanka</b>							
May 24, 1976	1	10	10	Cash	Subscription to the Memorandum of Association	0.00	[•]
September 14, 1976	(1)	10	10	Cash	Transfer of Equity Shares to F.R. Bhesania (nominee of Techno Electric & Engineering Company Limited)	0.00	[•]
March 28, 1977	6,000	10	10	Cash	Rights issue*	0.01	[•]
July 21, 1980	10,400	10	10	Cash	Rights issue*	0.02	[•]
December 6, 1980**	50	10	10	Cash	Transfer of Equity Shares by P. Sundaresan Menon	0.00	[•]
January 6, 1981**	100	10	10	Cash	Transfer of Equity Shares by Yashovardhan Sinha	0.00	[•]
November 6, 1984**	(1,500)	10	10	Cash	Transfer of Equity Shares to Madan Mohan Mohanka HUF	0.00	[•]
	(5,000)	10	10	Cash	Transfer of Equity Shares to Manju Mohanka	(0.01)	[•]
March 26, 1996	15,000	10	45	Cash	Transfer of Equity Shares by Industrial Finance Corporation of India	0.02	[•]
August 20, 1996	20,000	10	45	Cash	Transfer of Equity Shares by Industrial Credit and Investment Corporation of India	0.03	[•]
April 9, 1999	(22,000)	10	Nil	Gift	Transfer of Equity Shares to Manish Mohanka	(0.03)	[•]
	(23,000)	10	Nil	Gift	Transfer of Equity Shares to Mehul Mohanka	(0.03)	[•]
November 22, 2001	400,000	10	43	Cash	Transfer of Equity Shares by Svedala Skega AB	0.60	[•]
	(13,000)	10	43	Cash	Transfer of Equity Shares to Manju Mohanka	(0.02)	[•]
	(15,000)	10	43	Cash	Transfer of Equity Shares to Deluxe Investment & Agencies Private Limited	(0.02)	[•]
December 7, 2001	(322,000)	10	43	Cash	Transfer of Equity Shares to MM Global Private Limited	(0.49)	[•]
	(35,000)	10	43	Cash	Transfer of Equity Shares to Spencer Business Private Limited	(0.05)	[•]
September 30, 2004	63,669	10	10	Cash	Rights issue	0.09	[•]
October 5, 2013	944,628	10	N.A.	N.A.	Bonus issuance	1.42	[•]

Date of allotment/ transfer/ acquisition of shares	Number of equity shares allotted / transferred	Face value per equity share (₹)	Issue/ Acquisition/ transfer price per equity share (₹)	Nature of consideration	Nature of transaction	Percentage of pre-Offer equity share capital of the Company (%)	Percentage of post-Offer equity share capital of the Company (%)
April 21, 2015**	7,429,630	10	N.A.	Gift	Transfer of Equity Shares by Mehul Mohanka	11.21	[•]
	650	10	100	Cash	Transfer of Equity Shares by Nalini Ranjan Bhattacharjee	0.00	[•]
	650	10	100	Cash	Transfer of Equity Shares by Chand Kumar Paul	0.00	[•]
August 24, 2018**	2,600	10	100	Cash	Transfer of Equity Shares by Parth Sarathi Roy	0.00	[•]
	650	10	100	Cash	Transfer of Equity Shares by Kaberi Roy Choudhary	0.00	[•]
	650	10	100	Cash	Transfer of Equity Shares by Manohar Kachane	0.00	[•]
	3,250	10	100	Cash	Transfer of Equity Shares by Jeroo Dalal	0.00	[•]
January 10, 2020**	2,184,026	10	0.81	Other than cash	Transfer of Equity Shares by Madan Mohan Mohanka HUF	3.29	[•]
April 27, 2021**	(1,988,794)	10	Nil	Gift	Transfer of Equity Shares to Mehul Mohanka	(3.00)	[•]
June 30, 2021	6,500	10	225***	Cash	Transfer of Equity Shares by Raja Shah to Madan Mohan Mohanka	0.01	[•]
<b>(A) Sub-total</b>	<b>8,663,159</b>					<b>13.07</b>	<b>[•]</b>
<b>Mehul Mohanka</b>							
	2,000	10	15.02	Cash	Transfer of Equity Shares by Electro Zavod (India) Private Limited	0.00	[•]
June 7, 1986**	2,050	10	15.02	Cash	Transfer of Equity Shares by Durga Dutt Mohanka	0.00	[•]
	400	10	15.02	Cash	Transfer of Equity Shares by Savitri Devi Mohanka	0.00	[•]
January 30, 1993	500	10	5	Cash	Transfer of Equity Shares by Suresh Soni and Shanta Soni	0.00	[•]
December 21, 1993	300	10	18	Cash	Transfer of Equity Shares by Jeroo Dara Ankia & Dara Pirojshaw Ankia	0.00	[•]
June 28, 1995	863	10	20	Cash	Transfer of Equity Shares by Roma Basu	0.00	[•]
September 25, 1995**	200	10	30	Cash	Transfer of Equity Shares by Inder Singh Bassi and Ajit Kumar Bassi	0.00	[•]
	100	10	31	Cash	Transfer of Equity Shares by Ratan Mani Dutta	0.00	[•]
March 26, 1996	500	10	31	Cash	Transfer of Equity Shares by Ratan Lal Agarwal	0.00	[•]
	500	10	31	Cash	Transfer of Equity Shares by Prabha Agarwal	0.00	[•]
August 25, 1998	500	10	25	Cash	Transfer of Equity Shares by Vibha Gupta	0.00	[•]
	23,000	10	Nil	Gift	Transfer of Equity Shares by Madan Mohan Mohanka	0.03	[•]
April 9, 1999	7,000	10	25	Cash	Transfer of Equity Shares by Madan Mohan Mohanka HUF	0.01	[•]
September 2, 2002	304,200	10	N.A.	Other than cash	Scheme of amalgamation	0.46	[•]

Date of allotment/ transfer/ acquisition of shares	Number of equity shares allotted / transferred	Face value per equity share (₹)	Issue/ Acquisition/ transfer price per equity share (₹)	Nature of consideration	Nature of transaction	Percentage of pre-Offer equity share capital of the Company (%)	Percentage of post-Offer equity share capital of the Company (%)
September 30, 2004	66,313	10	10	Cash	Rights issue	0.10	[•]
March 22, 2005	163,084	10	10	Cash	Rights issue	0.25	[•]
October 5, 2013	6,858,120	10	N.A.	N.A.	Bonus issuance	10.35	[•]
April 21, 2015**	(7,429,630)	10	Nil	Gift	Transfer of Equity Shares to Madan Mohan Mohanka	(11.21)	[•]
April 7, 2021**	14,521	10	2.22	Other than cash	Transfer of Equity Shares by Mehul Mohanka HUF	0.02	[•]
April 27, 2021**	1,988,794	10	Nil	Gift	Transfer of Equity Shares by Madan Mohan Mohanka	3.00	[•]
<b>(B) Sub-total</b>	<b>2,003,315</b>					<b>3.02</b>	<b>[•]</b>
<b><i>Manish Mohanka</i></b>							
June 7, 1986**	3,000	10	15	Cash	Transfer of Equity Shares by Electro Zavod (India) Private Limited	0.000	[•]
	400	10	15	Cash	Transfer of Equity Shares by Savitri Devi Mohanka	0.00	[•]
January 30, 1993	500	10	5	Cash	Transfer of Equity Shares by Suresh Soni and Shanta Soni	0.00	[•]
March 28, 1995	100	10	20	Cash	Transfer of Equity Shares by Alka Nanda	0.00	[•]
June 28, 1995**	1,000	10	20	Cash	Transfer of Equity Shares by Ruma Basu	0.00	[•]
	50	10	31	Cash	Transfer of Equity Shares by Nirmal Dey	0.00	[•]
	50	10	31	Cash	Transfer of Equity Shares by Gobind Charan Mukherjee	0.00	[•]
	50	10	31	Cash	Transfer of Equity Shares by Subhashish Mukherjee	0.00	[•]
August 31, 1995	200	10	31	Cash	Transfer of Equity Shares by Ram Dhan Sharma	0.00	[•]
	2,000	10	30	Cash	Transfer of Equity Shares by Triton Trading Corporation Limited	0.00	[•]
	100	10	31	Cash	Transfer of Equity Shares by Niranjana Sasmal and Chhaya Sasmal	0.00	[•]
December 18, 1995	50	10	31	Cash	Transfer of Equity Shares by Asis Kumar Roy Chaudhuri	0.00	[•]
August 25, 1998	250	10	25	Cash	Transfer of Equity Shares by Vibha Gupta	0.00	[•]
April 9, 1999	22,000	10	Nil	Gift	Transfer of Equity Shares by Madan Mohan Mohanka	0.03	[•]
September 2, 2002	346,667	10	N.A.	Other than cash	Scheme of amalgamation	0.52	[•]
September 30, 2004	98,693	10	10	Cash	Rights issue	0.15	[•]
March 22, 2005	167,982	10	10	Cash	Rights issue	0.25	[•]
May 11, 2011	(32,180)	10	1,950.80	Cash	Transfer of Equity Shares to Wagner	(0.05)	[•]

Date of allotment/ transfer/ acquisition of shares	Number of equity shares allotted / transferred	Face value per equity share (₹)	Issue/ Acquisition/ transfer price per equity share (₹)	Nature of consideration	Nature of transaction	Percentage of pre-Offer equity share capital of the Company (%)	Percentage of post-Offer equity share capital of the Company (%)
October 5, 2013	7,330,944	10	N.A.	N.A.	Bonus issuance	11.06	[•]
<b>(C) Sub-total</b>	<b>7,941,856</b>					<b>11.98</b>	<b>[•]</b>
<b>Manju Mohanka</b>							
March 28, 1977	3,400	10	10	Cash	Rights issue*	0.01	[•]
July 21, 1980	500	10	10	Cash	Rights issue*	0.00	[•]
November 6, 1984**	5,000	10	8	Cash	Transfer of Equity Shares by Madan Mohan Mohanka	0.01	[•]
January 30, 1993**	10,000	10	8	Cash	Transfer of Equity Shares by Lalitkumar Manojkumar	0.02	[•]
January 30, 1993	2,700	10	7	Cash	Transfer of Equity Shares by Prithvi Nath Chaturvedi	0.00	[•]
December 7, 2001**	13,000	10	43	Cash	Transfer of Equity Shares by Madan Mohan Mohanka	0.02	[•]
September 30, 2004*	9,863	10	10	Cash	Rights issue	0.01	[•]
October 16, 2005**	200	10	50	Cash	Transfer of Equity Shares by Deva Priya Sen	0.00	[•]
May 6, 2006	50	10	50	Cash	Transfer of Equity Shares by Swapan Kumar Sarkar	0.00	[•]
May 11, 2011	(44,713)	10	1,950.80	Cash	Shares transferred to Wagner	(0.07)	[•]
<b>(D) Sub-total</b>	<b>Nil</b>					<b>0.00</b>	
<b>NFSPL</b>							
August 7, 2007	200,000	10	65	Cash	Further issue	0.30	
March 26, 2009**	2,611,781	10	12.69	Cash	Transfer of Equity Shares by High Value Equipment Company (Private) Limited	3.95	[•]
October 5, 2013	33,741,372	10	N.A.	N.A.	Bonus issuance	50.90	[•]
<b>(E) Sub-total</b>	<b>36,553,153</b>					<b>55.14</b>	
<b>Total (A+B+C+D+E)</b>	<b>55,161,483</b>					<b>83.21</b>	<b>[•]</b>

\* The resolution(s) passed by our Board and/or Shareholders and/or Form 2 in relation to such allotment of Equity Shares of our Company are untraceable and consequently, are unable to ascertain certain details about such allotments, including the nature of allotment, nature of consideration, and issue price per Equity Share. Our Company has, through letter dated July 5, 2021, preferred a right to information application before the Public Information Officer, Registrar of Companies, West Bengal requesting the authorities to provide all the Form 2 filings and the certified copies of documents available with the RoC in relation to our Company since its inception. Further, Aditya Tiwari & Company, Pratising Company Secretary has conducted an independent search at the RoC office and submitted a report dated July 14, 2021 to extract the Company's form filings.

\*\*The share transfer forms in relation to certain transfers of Equity Shares to or by our Promoters are untraceable. We have relied on alternate documentation such as register of transfer of shares, register of members, bank account statements and ledger accounts of our Promoters for verification of the abovementioned details of such transactions. For details, see "Risk Factors- We have been unable to locate certain of our historical corporate records." on page 31.

\*\*\* The weighted average price at which Equity Shares were acquired by Madan Mohan Mohanka and Mehul Mohanka in the one year preceding the date of this Red Herring Prospectus is ₹ 225 and ₹ 0.02, each as certified by SDT & Co, Chartered Accountants, by way of their certificate dated November 10, 2021. No Equity Shares were acquired by the remaining Promoters in the one year preceding the date of this Red Herring Prospectus.

All the equity shares held by our Promoters were fully paid-up on the respective dates of acquisition of such equity shares.

As on the date of this Red Herring Prospectus, none of the Equity Shares held by our Promoters are pledged.

**(b) Details of minimum promoters' contribution and lock-in for eighteen months**

Pursuant to Regulations 14 and 16 of the SEBI ICDR Regulations, an aggregate of 20% of the fully diluted post-Offer equity share capital of our Company held by our Promoters is required to be provided towards minimum promoters' contribution and locked-in for a period of 18 months from the date of Allotment.

Set forth below are the details of the [•] Equity Shares that will be locked-in as promoters' contribution from the date of Allotment\*:

Date of allotment/ acquisition of equity shares	Nature of Transaction	Face value per equity share (₹)	Offer/ Acquisition price per equity share (₹)	% of pre-Offer equity share capital	% of the fully diluted post-Offer equity share capital
[•]	[•]	[•]	[•]	[•]	[•]

\*To be completed prior to filing of the Prospectus with the RoC.

For details on the build-up of the equity share capital of our Company held by our Promoters, see “-*History of equity share capital build-up, contribution and lock-in of Promoters' shareholding shareholding - Build-up of Promoters' shareholding in our Company*” above.

Our Promoters have given their consent to include all Equity Shares held by them, constituting [•]% of the fully diluted post-Offer equity share capital of our Company as promoters' contribution. Our Promoters have agreed not to sell, transfer, charge, pledge or otherwise encumber in any manner the promoters' contribution from the date of this Red Herring Prospectus, until the expiry of the lock-in period specified above, or for such other time as required under SEBI ICDR Regulations, except as may be permitted, in accordance with the SEBI ICDR Regulations

The Equity Shares that are being locked-in are not, and will not be, ineligible for computation of promoters' contribution under Regulation 15 of the SEBI ICDR Regulations. In this regard, we confirm that:

- (i) the Equity Shares offered as part of the promoters' contribution do not comprise Equity Shares acquired during the three years immediately preceding the date of this Red Herring Prospectus for consideration other than cash and wherein revaluation of assets or capitalization of intangible assets was involved or bonus issue out of revaluations reserves or unrealized profits of the Company or against Equity Shares that are otherwise ineligible for computation of promoters' contribution;
- (ii) the promoters' contribution does not include Equity Shares acquired during the one year immediately preceding the date of this Red Herring Prospectus at a price lower than the price at which the Equity Shares are being offered to the public in the Offer;
- (iii) our Company has not been formed by conversion of a partnership firm into a company and hence, no Equity Shares have been issued in the one year immediately preceding the date of this Red Herring Prospectus pursuant to conversion of a partnership firm; and
- (iv) the Equity Shares held by our Promoters and offered as part of the promoters' contribution are not subject to any pledge.

All Equity Shares held by our Promoters are in dematerialized form.

**(c) Details of Equity Shares locked-in for six months**

In terms of Regulation 17 of the SEBI ICDR Regulations, the entire pre-Offer equity share capital of our Company will be locked-in for a period of six months from the date of Allotment in the Offer, except (a)

the promoters' contribution which shall be locked in as above; (b) the Equity Shares which may be allotted to the employees under the ESOP Schemes pursuant to exercise of options held by such employees (whether currently employees or not); and (c) Offered Shares, which are successfully transferred as part of the Offer for Sale.

As required under Regulation 20 of the SEBI ICDR Regulations, our Company shall ensure that the details of the Equity Shares locked-in are recorded by the relevant Depository. Any unsubscribed portion of the Offered Shares would also be locked-in as required under the SEBI ICDR Regulations.

**(d) Lock-in of Equity Shares Allotted to Anchor Investors**

Any Equity Shares Allotted to Anchor Investors in the Anchor Investor Portion shall be locked in for a period of 30 days from the date of Allotment.

**(e) Other requirements in respect of lock-in**

Pursuant to Regulation 21 of the SEBI ICDR Regulations, the Equity Shares held by our Promoters and locked-in for six months may be pledged only with scheduled commercial banks or public financial institutions or a Systemically Important NBFC or a housing finance company as collateral security for loans granted by such entities, provided that such pledge of the Equity Shares is one of the terms of the sanction of the loan. Equity Shares locked-in as promoters' contribution for eighteen months or such other periods, as may be prescribed under the SEBI ICDR Regulations can be pledged only if in addition to fulfilling the aforementioned requirements, such loans have been granted by such banks or financial institutions for the purpose of financing one or more of the objects of the Offer. However, such lock-in will continue pursuant to any invocation of the pledge and the transferee of the Equity Shares pursuant to such invocation shall not be eligible to transfer the Equity Shares until the expiry of the lock-in period stipulated above.

In terms of Regulation 22 of the SEBI ICDR Regulations, the Equity Shares held by our Promoters and locked-in pursuant to Regulation 16 of the SEBI ICDR Regulations for a period of eighteen months or such other periods, as may be prescribed under the SEBI ICDR Regulations, may be transferred amongst our Promoters and any member of the Promoter Group or to a new promoter, subject to continuation of lock-in applicable to the transferee for the remaining period and compliance with provisions of the Securities and Exchange Board of India (Substantial Acquisition of Shares and Takeovers) Regulations, 2011, as amended (the "Takeover Regulations").

Further, in terms of Regulation 22 of the SEBI ICDR Regulations, the Equity Shares held by persons other than our Promoters and locked-in pursuant to Regulation 17 of the SEBI ICDR Regulations for a period of six months or such other periods, as may be prescribed under the SEBI ICDR Regulations, may be transferred to any other person holding Equity Shares which are locked in along with the Equity Shares proposed to be transferred, subject to the continuation of the lock in applicable to the transferee and compliance with the provisions of the Takeover Regulations.

**9. Shareholding of our Promoter and Promoter Group**

Our Promoters and Promoter Group hold 83.21% of the pre-Offer Equity Share capital of our Company. Except as stated below, our promoters, the members of our Promoter Group and directors of our corporate Promoter, NFSPL, do not hold any Equity Shares in our Company as on date of this Red Herring Prospectus:

S. No.	Name of the member of the Promoter Group	Pre-Offer		Post-Offer	
		Number of Equity Shares held	% of the total shareholding*	Number of Equity Shares held	% of the total shareholding
<b>Promoters</b>					
1.	Madan Mohan Mohanka <sup>(1)</sup>	8,663,159	13.07	[•]	[•]
2.	Manish Mohanka	7,941,856	11.98	[•]	[•]
3.	Mehul Mohanka <sup>(1)</sup>	2,003,315	3.02	[•]	[•]
4.	NFSPL	36,553,153	55.14	[•]	[•]
<b>(A) Sub-total</b>		<b>55,161,483</b>	<b>83.21</b>	<b>[•]</b>	<b>[•]</b>
<b>Members of the Promoter Group</b>					



S. No.	Name of the member of the Promoter Group	Pre-Offer		Post-Offer	
		Number of Equity Shares held	% of the total shareholding*	Number of Equity Shares held	% of the total shareholding
1.	Marudhar*	1,300,000	1.96	[•]	[•]
	<b>(B) Sub-total</b>	<b>1,300,000</b>	<b>1.96</b>	<b>[•]</b>	<b>[•]</b>
	<b>Total (A+B)</b>	<b>56,461,483</b>	<b>85.17</b>	<b>[•]</b>	<b>[•]</b>

<sup>(1)</sup> Madan Mohan Mohanka and Mehul Mohanka are also the directors of our corporate Promoter, NFSPPL

\* Post the approval of the Scheme in accordance with applicable law, Marudhar will amalgamate with NFSPPL and will cease to exist as a member of our Promoter Group. For further details, please refer to “**Promoter and Promoter Group**” on page 199.

None of the Equity Shares held by our Promoters and the members of our Promoter Group is pledged or otherwise encumbered.

10. Except as stated under “- **History of equity share capital build-up, contribution and lock-in of Promoters’ shareholding - Build-up of Promoters’ shareholding in our Company**” above, none of the members of our Promoter Group, nor our Directors and their relatives has purchased or sold Equity Shares, during the six months immediately preceding the date of this Red Herring Prospectus.
11. There are no financing arrangements whereby the members of our Promoter Group, or our Directors or their relatives have financed the purchase of equity shares of our Company by any other person other than in the normal course of business during the six months immediately preceding the date of the Draft Red Herring Prospectus and this Red Herring Prospectus.

*[Remainder of the page has been intentionally left blank]*

## 12. Our shareholding pattern

Set forth below is the shareholding pattern of our Company as on the date of this Red Herring Prospectus:

Category (I)	Category of the Shareholder (II)	No. of Shareholders (III)	No. of fully paid up Equity Shares held (IV)	No. of partly paid-up Equity Shares held (V)	No. of shares underlying Depository Receipts (VI)	Total No. shares held (VII) = (IV)+(V)+(VI)	Shareholding as a % of total no. of shares (calculated as per SCRR, 1957) As a % of (A+B+C2) (VIII)	No. of Voting Rights held in each class of securities (IX)		No. of shares Underlying Outstanding convertible securities (including Warrants) (X)	Shareholding as a % assuming full conversion of convertible securities (as a % of diluted share capital)(XI)=(VI I)+ (X) as a % of (A+B+C2)	Number of Locked in shares (XII)		Number of shares pledged or otherwise encumbered (XIII)		Number of Equity Shares held in dematerialised form (XIV)	
								No. of Voting Rights (Equity shares)	Total as a % of total voting rights			No. (a)	As a % of total shares held (b)	No. (a)	As a % of total shares held (b)		
								Total									
(A)	Promoters & Promoter Group	5	56,461,483	0	0	56,461,483	85.17	56,461,483	85.17	0	0	0	0	0	0	56,461,483	
(B)	Public	31	9,831,666	0	0	9,831,666	14.83	9,831,666	14.83	0	0	0	0	0	0	9,704,890	
(C)	Non Promoter-Non Public	0	0	0	0	0	0	0	0	0	0	0	0	0	0	0	
(1)	Shares underlying Custodian/Depository Receipts	0	0	0	0	0	0	0	0	0	0	0	0	0	0	0	
(2)	Shares held by Employee Trust	0	0	0	0	0	0	0	0	0	0	0	0	0	0	0	
	Total (A)+(B)+(C)	36	66,293,149	0	0	66,293,149	100	66,293,149	100	0	0	0	0	0	0	66,166,373	

13. **Shareholding of our Directors and Key Managerial Personnel**

- (a) Except as stated below, none of our Directors or Key Managerial Personnel hold any Equity Shares in our Company.

Name of Directors/ KMP	No. of Equity Shares	% of pre-Offer equity share capital (%) <sup>*</sup>
<b>Directors</b>		
Madan Mohan Mohanka	8,663,159	13.07
Mehul Mohanka	2,003,315	3.02
<b>Total</b>	<b>10,666,474</b>	<b>16.09</b>

For stock options held by our Directors and Key Managerial Personnel, see “– Notes to Capital Structure” on page 79.

14. As on the date of this Red Herring Prospectus, our Company has 36 Shareholders.

15. **Details of shareholding of the major Shareholders of our Company**

The details of our Shareholders holding 1% or more of the paid-up share capital of our Company: (a) as on the date of this Red Herring Prospectus; (b) as of 10 days prior to the date of this Red Herring Prospectus; (c) as of one year prior to the date of this Red Herring Prospectus; and (d) as of two years prior to the date of this Red Herring Prospectus, are set out below:

- (a) Shareholders holding 1% or more of the paid-up share capital of our Company as on the date of this Red Herring Prospectus.

S. No.	Shareholder	Number of Equity Shares on a fully diluted basis <sup>^</sup>	Percentage of the Equity Share Capital on a fully diluted basis <sup>^</sup> (%)
1.	Madan Mohan Mohanka	8,663,159	13.00
2.	Manish Mohanka	7,941,856	11.91
3.	Mehul Mohanka	2,003,315	3.01
4.	Marudhar <sup>*</sup>	1,300,000	1.95
5.	NFSPL	36,553,153	54.84
6.	Wagner <sup>**</sup>	9,691,890	14.54
	<b>Total</b>	<b>66,153,373</b>	<b>99.25</b>

<sup>^</sup>The percentage of the Equity Share capital on a fully diluted basis has been calculated on the basis of total Equity Shares held by a shareholder and such number of Equity Shares which will result upon conversion of any stock options vested in such person.

<sup>\*</sup>Post the approval of the Scheme in accordance with applicable law, Marudhar will amalgamate with NFSPL and will cease to exist as a member of our Promoter Group. For further details, please see “Promoter and Promoter Group” on page 199.

<sup>\*\*</sup>Pursuant to resolutions dated November 10, 2021 passed by our Board and Shareholders, 8,692,281 CCPP held by Wagner Limited were converted to 8,692,281 Equity Shares, For details, see “- Notes to the Capital Structure – Equity Share capital history of our Company” and “- Notes to the Capital Structure – Preference Share capital history of our Company” above.

- (b) Shareholders holding 1% or more of the paid-up share capital of our Company as of 10 days prior to the date of this Red Herring Prospectus.

S. No.	Shareholder	Number of Equity Shares on a fully diluted basis <sup>^</sup>	Percentage of the Equity Share Capital on a fully diluted basis <sup>^</sup> (%)
1.	Madan Mohan Mohanka	8,663,159	13.00
2.	Manish Mohanka	7,941,856	11.91
3.	Mehul Mohanka	2,003,315	3.01
4.	Marudhar <sup>*</sup>	1,300,000	1.95
5.	NFSPL	36,553,153	54.84
6.	Wagner <sup>**</sup>	9,691,890	14.54
	<b>Total</b>	<b>66,153,373</b>	<b>99.25</b>

<sup>^</sup>The percentage of the Equity Share capital on a fully diluted basis has been calculated on the basis of total Equity Shares held by a shareholder and such number of Equity Shares which will result upon conversion of any stock options vested in such person and the CCPP held by such shareholder.

<sup>\*</sup>Post the approval of the Scheme in accordance with applicable law, Marudhar will amalgamate with NFSPL and will cease to exist as a member of our Promoter Group. For further details, please refer to “Promoter and Promoter Group” on page 199.

<sup>\*\*</sup>Pursuant to resolutions dated November 10, 2021 passed by our Board and Shareholders, 8,692,281 CCPP held by Wagner

Limited were converted to 8,692,281 Equity Shares, For details, see “- Notes to the Capital Structure – Equity Share capital history of our Company” and “- Notes to the Capital Structure – Preference Share capital history of our Company” above.

- (c) Shareholders holding 1% or more of the paid-up share capital of our Company as of one year prior to the date of this Red Herring Prospectus

S. No.	Shareholder	Number of Equity Shares on a fully diluted basis <sup>^</sup>	Percentage of the Equity Share Capital on a fully diluted basis <sup>^</sup> (%)
1.	Madan Mohan Mohanka	10,645,453	15.97
2.	Manish Mohanka	7,941,856	11.91
3.	Marudhar*	1,300,000	1.95
4.	NFSPL	36,553,153	54.84
5.	Wagner**	9,691,890	14.54
	<b>Total</b>	<b>66,132,352</b>	<b>99.21</b>

<sup>^</sup>The percentage of the Equity Share capital on a fully diluted basis has been calculated on the basis of total Equity Shares held by a shareholder and such number of Equity Shares which will result upon conversion of any stock options vested in such person and the CCPP held by such shareholder.

\*Post the approval of the Scheme in accordance with applicable law, Marudhar will amalgamate with NFSPL and will cease to exist as a member of our Promoter Group. For further details, please refer to “Promoter and Promoter Group” on page 199.

\*\*As of one year prior to the date of this Red Herring Prospectus, Wagner held 8,692,281 CCPP which were converted to 8,692,281 Equity Shares, pursuant to resolutions dated November 10, 2021 passed by our Board and Shareholders. For details, see “- Notes to the Capital Structure – Equity Share capital history of our Company” and “- Notes to the Capital Structure – Preference Share capital history of our Company” above.

- (d) Shareholders holding 1% or more of the paid-up share capital of our Company as of two years prior to the date of this Red Herring Prospectus

S. No.	Shareholder	Number of Equity Shares on a fully diluted basis <sup>^</sup>	Percentage of the Equity Share Capital on a fully diluted basis <sup>^</sup> (%)
1.	Madan Mohan Mohanka	84,61,427	12.70
2.	Madan Mohan Mohanka HUF	2,184,026	3.28
3.	Manish Mohanka	7,941,856	11.91
4.	Marudhar*	1,300,000	1.95
5.	NFSPL	36,553,153	54.84
6.	Wagner**	9,691,890	14.54
	<b>Total</b>	<b>66,132,352</b>	<b>99.22</b>

<sup>^</sup>The percentage of the Equity Share capital on a fully diluted basis has been calculated on the basis of total Equity Shares held by a shareholder and such number of Equity Shares which will result upon conversion of any stock options vested in such person and the CCPP held by such shareholder.

\*Post the approval of the Scheme in accordance with applicable law, Marudhar will amalgamate with NFSPL and will cease to exist as a member of our Promoter Group. For further details, please refer to “Promoter and Promoter Group” on page 199.

\*\*As of two years prior to the date of this Red Herring Prospectus, Wagner held 8,692,281 CCPP which were converted to 8,692,281 Equity Shares, pursuant to resolutions dated November 10, 2021 passed by our Board and Shareholders. For details, see “- Notes to the Capital Structure – Equity Share capital history of our Company” and “- Notes to the Capital Structure – Preference Share capital history of our Company” above.

## 16. Employee Stock Option Schemes

### ESOP 2011

ESOP 2011 was approved pursuant to a Board resolution dated January 4, 2011 and shareholders’ resolution dated February 18, 2011. As on the date of this Red Herring Prospectus, there are no outstanding options which are to be granted under ESOP 2011.

Under ESOP 2011, an aggregate of 498,628 options have been granted, 357,251 options have vested and no options have been exercised as on the date of this Red Herring Prospectus. The following table sets forth the particulars of the ESOP 2011 during the last three Financial Years, and as on the date of this Red Herring Prospectus:

The details of the ESOP 2011, as certified by SDT & Co, Chartered Accountants, through a certificate dated November 10, 2021 and November 23, 2021 are as follows:

Particulars	Details			
Total options outstanding as at the beginning of the period	Nil			
Total options granted	Cumulative options granted as on			
	Scheme	Date of Grant	Cumulative options	
	Grant I & II	04.03.2011	430,911	
	Grant III	16.11.2012	27,196	
	Grant IV	02.07.2013	18,707	
	Grant V	28.01.2015	21,814	
	Total	-	498,628	
Vesting period	Scheme	Vesting		
	Grant I	5 Years		
	Grant II	1 Year		
	Grant III	5 Years		
	Grant IV	5 Years		
	Grant V	5 Years		
Exercise price of options in ₹ (as on the date of grant options)	₹ 30.77 (Grant I & II) & ₹ 76.92 ( Grant III, IV & V)			
Options forfeited/lapsed/cancelled	141,377 <sup>1</sup>			
Variation of terms of options	Accelerated vesting in case of one employee in FY 2017. (Acacio Fernando)			
Money realized by exercise of options	Not yet exercised, hence no money realized.			
Total number of options outstanding in force	357,251			
Total options vested (excluding the options that have been exercised)	357,251			
Options exercised (since implementation of the ESOP scheme)	Nil			
The total number of Equity Shares arising as a result of exercise of granted options (including options that have been exercised)	357,251			
Employee wise details of options granted to:				
(i) Key managerial personnel	<b>Name of key managerial personnel</b>		<b>Total no. of options granted<sup>2</sup></b>	
	Mr. S Y Imam		44,070	
	Ms. Rakhi Sarkar <sup>3</sup>		6,474	
(ii) Any other employee who receives a grant in any one year of options amounting to 5% or more of the options granted during the year	<b>Name of employee</b>		<b>Financial Year</b>	
	<b>Total no. of options granted<sup>4</sup></b>			
	Andrew Menear		2010-11	36,400
	Graeme Robert Kibell		2010-11	25,168
	Sandeep Biswas		2010-11	22,503
	Vinay Grover		2010-11	23,712
	Accacio Fernando Monteiro		2012-13	27,196
	Accacio Fernando Monteiro		2013-14	18,707
Accacio Fernando Monteiro		2014-15	9,347	

<sup>1</sup> Nomination and Remuneration committee meeting held on August 3, 2021 has confirmed the cancellation of options under ESOP 2011 Scheme.

<sup>2</sup> For KMP total number of option is including the effect of bonus

<sup>3</sup> Ms. Rakhi Sarkar resigned as a Company Secretary w.e.f August, 31 2018.

<sup>4</sup> For employee total number of option is including the effect of bonus

Particulars	Details	
(iii) Identified employees who were granted options during any one year equal to or exceeding 1% of the issued capital (excluding outstanding warrants and conversions) of the Company at the time of grant	Nil	
Diluted earnings per share pursuant to the issue of Equity Shares on exercise of options in accordance with IND AS 33 'Earnings Per Share'	Fiscal 2019	Rs.4.90/-
	Fiscal 2020	Rs.9.84/-
	Fiscal 2021	Rs.20.48/-
Where the Company has calculated the employee compensation cost using the intrinsic value of the stock options, the difference, if any, between employee compensation cost so computed and the employee compensation calculated on the basis of fair value of the stock options and the impact of this difference, on the profits of the Company and on the earnings per share of the Company	NA	
Method and significant assumptions used to estimate the fair value of options granted during the year including, weighted average information, namely, risk-free interest rate, expected life, expected volatility, expected dividends, and the price of the underlying share in the market at the time of grant of option	For Fiscal FY 2019: Nil For Fiscal FY 2020: Nil For Fiscal FY 2021: Nil	
Impact on the profits and on the Earnings Per Share of the last three years if the accounting policies specified in the Securities and Exchange Board of India (Share Based Employee Benefits) Regulations, 2014 had been followed, in respect of options granted in the last three years	For Fiscal FY 2019: Nil For Fiscal FY 2020: Nil For Fiscal FY 2021: Nil	

Particulars	Details
Intention of key managerial personnel and whole-time directors who are holders of Equity Shares allotted on exercise of options to sell their shares within three months after the listing of Equity Shares pursuant to the Offer	Based on declaration obtained by the Company none of the Key Managerial Personnel and Whole-time Directors are intending to sell the Equity Shares acquired within three months after listing of Equity Shares pursuant to the Offer.
Intention to sell Equity Shares arising out of the ESOP scheme or allotted under an ESOP scheme within three months after the listing of Equity Shares by directors, senior managerial personnel and employees having Equity Shares arising out of the ESOP scheme, amounting to more than 1% of the issued capital (excluding outstanding warrants and conversions)	As on the date of this Red Herring Prospectus, none of the Directors, senior managerial personnel and employees hold Equity Shares amounting to more than 1% of the issued capital (excluding outstanding warrants and conversions) arising out of the ESOP Scheme.

#### *ESOP 2021*

ESOP 2021 was approved pursuant to a Board resolution dated August 3, 2021 and Shareholders' resolution dated August 7, 2021 and further amended by Board resolution dated November 10, 2021. ESOP 2021 is in compliance with the SEBI SBEB SE Regulations.

Under ESOP 2021, no options have been granted, vested and exercised as on the date of this Red Herring Prospectus.

17. Our Company presently does not intend or propose to alter the capital structure for a period of six months from the Bid/Offer Opening Date, by way of split or consolidation of the denomination of Equity Shares, or further issue of Equity Shares (including issue of securities convertible into or exchangeable for, directly or indirectly into Equity Shares), whether on a preferential basis or issue of bonus or rights issue or further public issue of Equity Shares or otherwise. Provided, however, that the foregoing restrictions do not apply to any issuance of Equity Shares, pursuant to the exercise of employee stock options under ESOP schemes.
18. Our Company, our Directors and the BRLMs have not entered into any buy-back arrangements for the purchase of Equity Shares being offered through this Offer.
19. The Equity Shares are fully paid-up and there are no partly paid-up Equity Shares as on the date of this Red Herring Prospectus. The Equity Shares to be issued or transferred pursuant to the Offer shall be fully paid up at the time of Allotment.
20. The BRLMs and their respective associates (as defined under the Securities and Exchange Board of India (Merchant Bankers) Regulations, 1992) do not hold any Equity Shares as on the date of this Red Herring Prospectus. The BRLMs and their respective associates may engage in transactions with, and perform services for our Company, the Selling Shareholders and their respective affiliates or associates in the ordinary course of business, and have engaged, or may in the future engage in commercial banking and investment banking transactions with our Company or the Selling Shareholders or their respective affiliates or associates for which they have received, and may in future receive compensation.
21. No person connected with the Offer, including, but not limited to, our Company, the Promoter Group, the Selling Shareholders, the members of the Syndicate, or our Directors, shall offer any incentive,

whether direct or indirect, in any manner, whether in cash or kind or services or otherwise to any Bidder for making a Bid, except for fees or commission for services rendered in relation to the Offer.

22. Except for options granted under the ESOP Schemes, there are no outstanding warrants, options or rights to convert debentures, loans or other convertible instruments into Equity Shares as on the date of this Red Herring Prospectus.
23. Except for any issue of Equity Shares pursuant to exercise of options granted under the ESOP Schemes, there will be no further issue of Equity Shares whether by way of issue of bonus shares, preferential allotment, rights issue or in any other manner during the period commencing from the date of this Red Herring Prospectus with SEBI until the Equity Shares have been listed on the Stock Exchanges or all application monies have been refunded, as the case may be.
24. There shall be only one denomination of the Equity Shares, unless otherwise permitted by law. Our Company will comply with such disclosure and accounting norms as may be specified by SEBI from time to time.
25. Our Company shall ensure that transactions in Equity Shares by our Promoters and our Promoter Group during the period between the date of filing of this Red Herring Prospectus and the date of closure of the Offer shall be reported to the Stock Exchanges within 24 hours of such transaction.
26. **Details of acquisition of Equity Shares acquired in the last three years immediately preceding the date of this Red Herring Prospectus**

Except our Promoters, Madan Mohan Mohanka and Mehul Mohanka and Selling Shareholders, Madan Mohan Mohanka and Wagner Limited, none of our Promoters, members of the Promoter Group and Selling Shareholders have acquired Equity Shares of our Company in the last three years preceding the date of this Red Herring Prospectus. The details of the Equity Shares acquired in the last three years by Wagner Limited are set out below.

Date of allotment/ transfer/ acquisition of shares	Number of equity shares allotted / transferred	Face value per equity share (₹)	Issue/ Acquisition/ transfer price per equity share (₹)	Nature of consideration	Nature of transaction
November 10, 2021	8,692,281*	10	N.A.	N.A.	Conversion of CCPP in the ratio of 1:1

\* For details of these Equity Shares allotted to Wagner Limited, see “- Notes to the Capital Structure – Equity Share capital history of our Company” and “- Notes to the Capital Structure – Preference Share capital history of our Company” above.

For details of the Equity Shares acquired in the last three years by Madan Mohan Mohanka and Mehul Mohanka, see “-*History of equity share capital build-up, contribution and lock-in of Promoters’ shareholding*” above.

A Bidder cannot make a Bid exceeding the number of Equity Shares offered through this Offer and subject to the investment limits or maximum number of Equity Shares that can be held by them under applicable law. For more information, see “*Offer Procedure*” beginning on page 380.



## OBJECTS OF THE OFFER

The objects of the Offer are to achieve the benefits of listing the Equity Shares on the Stock Exchanges and for the Offer for Sale of up to 13,669,478 Equity Shares. For further details, see “*The Offer*” on page 64.

Our Company expects that listing of the Equity Shares will enhance our visibility and brand and provide liquidity to its existing Shareholders. Listing will also provide a public market for the Equity Shares in India. Our Company will not receive any proceeds from the Offer. All proceeds from the Offer will go to the Selling Shareholders, in proportion to the Equity Shares offered by them in the Offer for Sale.

### Offer related expenses

The total expenses of the Offer are estimated to be approximately ₹[•] million. The expenses of this Offer include, among others, listing fees, selling commission and brokerage, fees payable to the BRLMs, fees payable to legal counsel, fees payable to the Registrar to the Offer, Escrow Collection Bank(s) and Sponsor Bank to the Offer, processing fee to the SCSBs for processing application forms, brokerage and selling commission payable to members of the Syndicate, Registered Brokers, RTAs and CDPs, printing and stationery expenses, advertising and marketing expenses and all other incidental and miscellaneous expenses for listing the Equity Shares on the Stock Exchanges.

Other than listing fees, which will be paid by our Company, all costs, fees and expenses with respect to the Offer (except for any interest payable by the Company and/ or any Selling Shareholder on refund of application money in relation to the Offer) will be reimbursed to our Company by the Selling Shareholders (in proportion to their respective Offered Shares) upon listing of the Equity Shares as well as in the event of failure of the Offer or withdrawal of the Draft Red Herring Prospectus.

The estimated Offer expenses are as follows:

Activity	Estimated expenses*	As a % of the total estimated Offer expenses	As a % of the total Offer size
(₹ in million)			
Fees payable to the BRLMs and commissions (including underwriting commission, brokerage and selling commission)	[•]	[•]	[•]
Advertising and marketing expenses	[•]	[•]	[•]
Fees payable to the Registrar to the Offer	[•]	[•]	[•]
Commission/processing fee for SCSBs, Sponsor Bank and Bankers to the Offer. Brokerage, underwriting commission and selling commission and bidding charges for Members of the Syndicate, Registered Brokers, RTAs and CDP <sup>(1)(2)</sup>	[•]	[•]	[•]
Printing and distribution of issue stationery	[•]	[•]	[•]
Fees to regulators, including Stock Exchanges	[•]	[•]	[•]
Others	[•]	[•]	[•]
(i) Listing fees, SEBI, BSE and NSE processing fees;			
(ii) Book building software fees;			
(iii) Other regulatory expenses;			
(iv) Fees payable to legal counsels; and			
(v) Miscellaneous.			
<b>Total estimated Offer expenses</b>	<b>[•]</b>	<b>[•]</b>	<b>[•]</b>

\* Offer expenses include applicable taxes, where applicable. Offer expenses will be incorporated at the time of filing of the Prospectus. Offer expenses are estimates and are subject to change.

Notes:

#### For SCSBs

Selling commission payable to the SCSBs on the portion for Retail Individual Bidders and Non- Institutional Bidders which are directly procured and uploaded by them would be as follows:

Portion for Retail Individual Bidders	0.35% of the Amount Allotted* (plus applicable taxes)
Portion for Non- Institutional Bidders	0.20% of the Amount Allotted* (plus applicable taxes)

\* Amount Allotted is the product of the number of Equity Shares Allotted and the Issue Price

No additional uploading/processing charges shall be payable to the SCSBs on the applications directly procured by them.

The Selling Commission payable to the SCSBs will be determined on the basis of the bidding terminal id as captured in the bid book of BSE or NSE.

**Processing fees payable to the SCSBs** of Rs. 10/- per valid application (plus applicable taxes) for processing the Bid cum Application of Retail Individual Bidders and Non-Institutional Bidders procured from the Syndicate /Sub-Syndicate Members/Registered Brokers /RTAs /CDPs and submitted to SCSBs for blocking. SCSBs will be entitled to a processing fee of ₹10 (plus applicable taxes), per valid ASBA Form.

**For Syndicate (including their Sub-syndicate members), RTAs and CDPs**

**Brokerages, selling commission and processing/uploading charges** on the portion for Retail Individual Investors (using the UPI mechanism) and Non-Institutional Bidders which are procured by members of Syndicate (including their Sub-Syndicate Members), RTAs and CDPs or for using 3-in-1 type accounts- linked online trading, demat & bank account provided by some of the brokers which are members of Syndicate (including their Sub-Syndicate Members) would be as follows:

Portion for Retail Individual Bidders	0.35% of the Amount Allotted* (plus applicable taxes)
Portion for Non-Institutional Bidders	0.20% of the Amount Allotted* (plus applicable taxes)

\*Amount Allotted is the product of the number of Equity Shares Allotted and the Issue Price

The Selling Commission payable to the Syndicate / Sub-Syndicate Members will be determined on the basis of the application form number / series, provided that the application is also bid by the respective Syndicate / Sub-Syndicate Member. For clarification, if a Syndicate ASBA application on the application form number/ series of a Syndicate / Sub-Syndicate Member, is bid by an SCSB, the Selling Commission will be payable to the SCSB and not the Syndicate / Sub-Syndicate Member.

The payment of Selling Commission payable to the sub-brokers / agents of Sub-Syndicate Members are to be handled directly by the respective Sub-Syndicate Member.

The Selling Commission payable to the RTAs and CDPs will be determined on the basis of the bidding terminal id as captured in the bid book of BSE or NSE.

**Uploading Charges/ Processing Charges of Rs.30/-** valid application (plus applicable taxes) are applicable only in case of bid uploaded by the members of the Syndicate, RTAs and CDPs:

- for applications made by Retail Individual Investors using the UPI Mechanism

**Uploading Charges/ Processing Charges of Rs.10/-** valid application (plus applicable taxes) are applicable only in case of bid uploaded by the members of the Syndicate, RTAs and CDPs:

- for applications made by Retail Individual Bidders using 3-in-1 type accounts
- for Non-Institutional Bidders using Syndicate ASBA mechanism / using 3- in -1 type accounts,

The Bidding/uploading charges payable to the Syndicate / Sub-Syndicate Members, RTAs and CDPs will be determined on the basis of the bidding terminal id as captured in the bid book of BSE or NSE.

**For Registered Brokers**

Selling commission payable to the registered brokers on the portion for Retail Individual Bidders & Non-Institutional Bidders which are directly procured by the Registered Brokers and submitted to SCSB for processing would be as follows:

Portion for Retail Individual & Non-Institutional Bidders	₹ 10/- per valid application* (plus applicable taxes)
---	---

\*Based on valid applications.

**For Sponsor Bank**

Processing fees for applications made by Retail Individual Bidders using the UPI mechanism will be

Sponsor Bank	₹6/- per valid Bid cum Application Form* (Inclusive of all taxes)
--------------	---

\* For each valid application.

The Sponsor Bank shall be responsible for making payments to the third parties such as remitter bank, NPCI and such other parties as required in connection with the performance of its duties under the SEBI circulars, the Syndicate Agreement and other applicable laws.

The processing fees for applications made by Retail Individual Bidders using the UPI Mechanism may be released to the remitter banks (SCSBs) only after such banks provide a written confirmation on compliance with SEBI Circular No: SEBI/HO/CFD/DIL2/CIR/P/2021/570 dated June 02, 2021 read with SEBI Circular No: SEBI/HO/CFD/DIL2/CIR/P/2021/2480/1/M dated March 16, 2021.

## BASIS FOR OFFER PRICE

The Offer Price will be determined by our Company and the Selling Shareholders, in consultation with the BRLMs, on the basis of assessment of market demand for the Equity Shares offered through the Book Building Process and on the basis of qualitative and quantitative factors as described below. The face value of the Equity Shares is ₹10 and the Offer Price is [•] times the face value at the lower end of the Price Band and [•] times the face value at the higher end of the Price Band.

Investors should also refer to “*Risk Factors*”, “*Business*” and “*Financial Information*” on pages 23, 141 and 207, respectively, to have an informed view before making an investment decision.

### Qualitative Factors

Some of the qualitative factors which form the basis for the Offer Price are:

1. A leading producer of specialized and “critical to operate” products, with high barriers to replacement or substitution;
2. Insulated from mining capex cycles, as our products cater to after-market spends, providing recurring revenues;
3. High value add and technology intensive products, backed by strong R&D and focus on quality control;
4. Long standing market player with marquee global customer base and strong global manufacturing and sales capabilities;
5. Consistent growth, characterized by operational efficiency and high repeat business; and
6. Experienced management team supported by large, diverse and skilled work force.

For further information, see “*Business - Strengths*” on page 143.

### Quantitative Factors

Some of the information presented in this chapter is derived from the Restated Financial Information. For further information, see “*Financial Information*” beginning on page 207.

Some of the quantitative factors which may form the basis for computing the Offer Price are as follows:

#### 1. Basic and Diluted Earnings per Share

Fiscal / period ended	Basic EPS (₹)	Diluted EPS (₹)	Weight
March 31, 2021	24.10	20.48	3
March 31, 2020	11.57	9.84	2
March 31, 2019	5.76	4.90	1
<b>Weighted Average</b>	<b>16.87</b>	<b>14.34</b>	
June 30, 2021*	2.10	1.78	-

\* Not annualized

#### Notes:

- <sup>a</sup> Basic EPS = Restated consolidated profit for the period/ year attributable to equity holders of the Company divided by Weighted average number of equity shares outstanding during the period/ year
- <sup>b</sup> Diluted EPS = Restated consolidated profit for the period/ year attributable to equity holders of the Company divided by Weighted average number of dilutive equity shares outstanding during the period/ year
- <sup>c</sup> Weighted average is aggregate of year-wise weighted EPS divided by the aggregate of weights i.e. {(EPS x Weight) for each year} / {Total of weights}
- <sup>d</sup> EPS has been calculated in accordance with the Indian Accounting Standard 33 – “Earnings per share”
- <sup>e</sup> The face value of equity shares of our Company is ₹10
- <sup>f</sup> The figures disclosed above are based on the Restated Consolidated Financial Information of our Company.
- <sup>g</sup> Pursuant to resolutions dated November 10, 2021 passed by our Board and Shareholders, 8,692,281 CCPP held by Wagner Limited were converted to 8,692,281 Equity Shares. The same have not been taken into account for the purpose of computation given above.

## 2. Price/Earning (“P/E”) Ratio in relation to the Price Band of ₹[•] to ₹[•] per Equity Share:

Particulars	P/E at Floor Price (no. of times)	P/E at Cap Price (no. of times)
Based on basic EPS of ₹ [•] as per the Restated Financial Information for the year ended March 31, 2021	[•]	[•]
Based on diluted EPS of ₹ [•] as per the Restated Financial Information for the year ended March 31, 2021	[•]	[•]

### Industry P/E ratio\*

Particulars	P/E
Highest	31.71
Lowest	31.71
Average	31.71

\*Source: The highest, lowest and average Industry P/E shown above is based on the industry peer set provided below under “- Comparison with Listed Industry Peers” below.

## 3. Average return on Net Worth (“RoNW”) (on a consolidated basis)

Fiscal ended	RoNW (%)	Weight
March 31, 2021	22.23	3
March 31, 2020	14.16	2
March 31, 2019	8.14	1
<b>Weighted Average</b>	<b>17.19</b>	-
June 30, 2021*	1.88	-

\* Not annualized

### Notes:

- Return on Net Worth (%) = Restated profit for the period/ year of the Company divided by net worth.
- Net worth means the aggregate value of the equity share capital, preference share capital and other equity, as per restated consolidated financial information.
- Weighted average is aggregate of year-wise weighted RoNW divided by the aggregate of weights i.e.  $\{(RoNW \times Weight) \text{ for each year} \} / \{Total \text{ of weights} \}$

## 4. Net Asset Value (“NAV”)

Net Asset Value per Equity Share	(₹)
As on March 31, 2021	105.04
As on June 30, 2021	108.06
After the Offer	[•]

### Notes:

- Net Asset Value per equity share represents net worth attributable to Equity Shareholder (Equity Share capital together with other equity as per Restated Consolidated Financial Information) as at the end of the fiscal year divided by the number of Equity Shares outstanding at the end of the period/ year
- Pursuant to resolutions dated November 10, 2021 passed by our Board and Shareholders, 8,692,281 CCPP held by Wagner Limited were converted to 8,692,281 Equity Shares. The same have not been taken into account for the purpose of computation of NAV given above.

## 5. Comparison with Listed Industry Peers

Following is the comparison with our peer group companies listed in India and in the same line of business as our Company:

Name of the company	Consolidated	Face value (₹ per share)	Closing price on November 9, 2021 (₹)	Total Income (in ₹ million)	EPS (₹)		NAV <sup>(2)</sup> (₹ per share)	P/E <sup>(3)</sup>	RoNW <sup>(4)</sup> (%)
					Basic	Diluted <sup>(1)</sup>			
Company <sup>#</sup>	Consolidated	10	NA	8,566.84	24.10	20.48	105.04	NA	22.23
<b>PEER GROUP</b>									
AIA Engineering Limited	Consolidated	2	1,903.50	30,536.88	60.02	60.02	449.99	31.71	13.33

Source: All the financial information for listed industry peer mentioned above is on a consolidated basis and is sourced from the audited financial results of the company for the year ended March 31, 2021 available on the websites of BSE.

#Source for our Company: Based on the Restated Consolidated Financial Information for the year ended March 31, 2021.

**Notes:**

- <sup>1.</sup> *Basic EPS = Profit for the year attributable to equity holders of the Company divided by Weighted average number of equity shares outstanding during the year*
- <sup>2.</sup> *Diluted EPS = Profit for the year attributable to equity holders of the Company divided by Weighted average number of dilutive equity shares outstanding during the year*
- <sup>3.</sup> *Net Asset Value per equity share represents net worth attributable to Equity Shareholder (Equity Share capital together with other equity as per Restated Consolidated Financial Information) as at the end of the fiscal year divided by the number of Equity Shares outstanding at the end of the year*
- <sup>4.</sup> *P/E Ratio has been computed based on the closing market price of equity shares on BSE on November 9, 2021, divided by the Basic EPS*
- <sup>5.</sup> *Return on net worth (%) = Restated profit for the year of the Company divided by net worth (Net worth means the aggregate value of the equity share capital, preference share capital and other equity, as per restated consolidated financial information.)*
- <sup>6.</sup> *Weighted average is aggregate of year-wise weighted RoNW divided by the aggregate of weights i.e. {(RoNW x Weight) for each year} / {Total of weights}*

The trading price of the Equity Shares could decline due to the factors mentioned in the section titled “**Risk Factors**” beginning on page 23 and any other factors that may arise in the future and you may lose all or part of your investments.

The Offer Price of ₹[•] has been determined by our Company and Selling Shareholders, in consultation with the BRLMs, on the basis of the demand from investors for the Equity Shares through the Book-Building Process. Our Company and the Selling Shareholders, in consultation with the BRLMs, is justified of the Offer Price in view of the above qualitative and quantitative parameters. Investors should read the abovementioned information along with “**Risk Factors**”, “**Business**” and “**Financial Information**” on pages 23, 141 and 207, respectively, to have a more informed view. The trading price of the Equity Shares could decline due to the factors mentioned in “**Risk Factors**” or any other factors that may arise in the future and you may lose all or part of your investments.

## STATEMENT OF POSSIBLE TAX BENEFITS

To,

**The Board of Directors,  
Tega Industries Limited**  
147, Block-G, New Alipore,  
Kolkata – 700 053

**Axis Capital Limited**  
Axis House  
1<sup>st</sup> Floor, Wadia International Centre,  
PandurangBudhkar Marg, Worli,  
Mumbai 400 025

**JM Financial Limited**  
7th Floor, Cnergy,  
AppasahebMarathe Marg,  
Prabhadevi, Mumbai 400 025

(Axis Capital Limited, JM Financial Limited with any other book running lead managers which may be appointed in relation to the Offer are collectively referred to as the “Book Running Lead Managers” or the “BRLMs”)

Dear Sirs/Madams,

**Re: Proposed initial public offering of equity shares of face value of Rs. 10 each (the “Equity Shares” and such offering, the “Offer”) of Tega Industries Limited (the “Company”)**

We report that the enclosed statement in the **Annexure A**, states the possible special tax benefits under direct and indirect tax laws presently in force in India, available to the Company, its shareholders and to its material subsidiaries as identified by the Company as per the Securities and Exchange Board of India (Listing Obligations and Disclosure Requirements) Regulations, 2015, as amended being Tega Industries Chile SpA, Tega Industries Africa Proprietary Limited, Tega Holdings Pte Ltd and Losugen Pty Ltd (such entities referred to as “**Material Subsidiaries**”). Several of these benefits are dependent on the Company, its shareholders or its Material Subsidiaries, as the case may be, fulfilling the conditions prescribed under the relevant provisions of the statute. Hence, the ability of the Company, its shareholders or its Material Subsidiaries to derive the special tax benefits is dependent upon their fulfilling such conditions, which based on business imperatives the Company, its shareholders and its Material Subsidiaries faces in the future, the Company, its shareholders and its Material Subsidiaries may or may not choose to fulfill.

The benefits discussed in the enclosed **Annexure A** are not exhaustive. This statement is only intended to provide general information to the investors and is neither designed nor intended to be a substitute for professional tax advice. In view of the individual nature of the tax consequences and the changing tax laws, each investor is advised to consult his or her own tax consultant with respect to the specific tax implications arising out of their participation in the Offer. Neither are we suggesting nor advising the investor to invest in the Offer based on this statement.

The preparation of the accompanying statement in annexure B as prepared by the Company and initialed by us on quantum of special tax benefits of Income Tax Act, 1961 is accurate, complete, and free from misstatement is the responsibility of the management of the Company including the preparation and maintenance of all accounting and other relevant supporting records and documents. This responsibility includes designing, implementation and maintaining control relevant to the preparation and presentation of the financial and other statements, applying an appropriate basis of preparations that is reasonable in the circumstances.

We do not express any opinion or provide any assurance as to whether:

- I. the Company, its shareholders or its Material Subsidiaries will continue to obtain these benefits in future; or
- II. the conditions prescribed for availing the benefits have been/would be met with; or

III. the revenue authorities will concur with the views expressed herein.

The contents of the enclosed statement are based on information, explanations and representations obtained from the Company and its Material Subsidiaries and based on our understanding of the business activities and operations of the Company and its Material Subsidiaries.

We have carried out work based on Restated Consolidated Financial Statements and other documents, and information made available to us by the Company and subsidiaries, which has formed a substantial basis for this letter. We were not appointed as the statutory auditor and have not audited the Company and subsidiaries or its financial statements. Accordingly, we do not express any form of opinion on the financial statements. Any change in the information made available to us by the Company and its subsidiaries which forms a substantial basis of our verification, subsequent to the issuance of this letter has not been considered.

We also consent to the references to us as “Experts” as defined under Section 2(38) of the Companies Act, 2013 (the “CA, 2013”), read with Section 26(5) of the CA, 2013 to the extent of the certification provided hereunder and included in the red herring prospectus and prospectus of the Company or in any other documents in connection with the Offer.

We hereby give consent to include this statement of special tax benefits in the red herring prospectus, prospectus and in any other material used in connection with the Offer (together, the “Offer Documents”).

This certificate is issued for the sole purpose of the Offer, and can be used, for inclusion in the Offer Documents, and for the submission of this certificate as may be necessary, to any regulatory / statutory authority, stock exchanges, any other authority as may be required and/or for the records to be maintained by the Lead Managers in connection with the Offer and in accordance with applicable law, and for the purpose of any defense the Lead Managers may wish to advance in any claim or proceeding in connection with the contents of the Offer Documents.

This certificate may be relied on by the Lead Managers, their affiliates and legal counsel in relation to the Offer.

Yours faithfully,

**For, S D T & Co.,  
Chartered Accountants  
ICAI Firm Registration No.: 112226W**

**Dilip K. Thakkar  
Partner  
Membership No.: 031269  
Peer Review Certificate No.:013689  
UDIN: 21031269AAAARD3235  
Date: November 10, 2021  
Place: Vadodara**

**Encl:As above**

## Annexure A

### STATEMENT OF SPECIAL TAX BENEFITS AVAILABLE TO THE COMPANY AND ITS SHAREHOLDERS

This statement of possible special tax benefits is required as per Schedule VI (Part A) (9)(L) of the ICDR Regulations. While the term '*special tax benefits*' has not been defined under the ICDR Regulations, for the purpose of this Statement, it is assumed that with respect to special tax benefits available to the Company, the same would include those benefits as enumerated in this Annexure. Any benefits under the taxation laws other than those specified in this Annexure are considered to be general tax benefits and therefore not covered within the ambit of this Statement. Further, any benefits available under any other laws within or outside India, except for those mentioned in this Annexure have not been examined and covered by this statement.

#### Direct Taxation:

Outlined below are the special tax benefits available to the Company, its Material Subsidiaries and its shareholders under the Income-tax Act, 1961 ('the Act'), as amended by Finance Act, 2020 i.e., applicable for Financial Year 2020-21 relevant to the Assessment Year 2021-22, presently in force in India.

#### I. Special tax benefits available to the Company

The Company is eligible to opt for and as representation obtained from the management, the Company has opted for the beneficial tax rate of 22% (plus applicable surcharge and cess, effectively 25.17%) as provided under Section 115BAA of the Act, subject to the condition that going forward it does not claim the deductions as specified in Section 115BAA(2) of the Act and computes total income as per the provisions of Section 115BAA (2) of the Act. Proviso to Section 115BAA(5) provides that once the Company opts for paying tax as per Section 115BAA of the Act, such option cannot be subsequently withdrawn for the same or any other Previous Year. The Company will exercise the option under this Section on or before the due date of filing the returns under sub-section (1) of Section 139 of the Act for the Previous Year relevant to the Assessment Year 2021-2022.

#### II. Special tax benefits available to Shareholders

- There are no special tax benefits available to the shareholders for investing in the shares of the Company

#### III. Special tax benefits available to Material Subsidiaries

- There are no special tax benefit is available to subsidiaries of the Company

#### Notes:

1. The above Statement sets out the provisions of law in a summary manner only and is not a complete analysis or listing of all potential tax consequences of the purchase, ownership and disposal of shares.
2. The above Statement covers only certain relevant benefits under Income tax Act, 1961 read with relevant rules, circulars and notifications and does not cover any indirect tax law benefits or benefit under any other law.
3. The above Statement of possible tax benefits is as per the current Income tax Act, 1961 read with relevant rules, circulars and notifications relevant for the Assessment Year 2021-22.
4. This Statement is intended only to provide general information to the investors and is neither designed nor intended to be a substitute for professional tax advice. In view of the individual nature of tax consequences, each investor is advised to consult his/her own tax advisor with respect to specific tax consequences of his/her investment in the shares of the Company.
5. In respect of non-residents, the tax rates and consequent taxation will be further subject to any benefits available under the relevant double tax avoidance agreements, if any, between India and the country in which such non-resident is a tax resident of.
6. Our views expressed in this Statement are based on the facts and assumptions as indicated in the Statement. No assurance is given that the revenue authorities/courts will concur with the views expressed herein. Our views are based on the existing provisions of law and its interpretation, which are subject to changes from time to time. We do not assume responsibility to update the views consequent to such changes.

#### Indirect Taxation:

Outlined below are the special tax benefits available to the Company, its Material Subsidiaries and its shareholders under the Central Goods and Services Tax Act, 2017, the Integrated Goods and Services Tax Act, 2017 ("GST law"), the Customs Act, 1962, Customs Tariff Act, 1975 ("Customs law") and Foreign Trade Policy 2015-2020 ("FTP") (collectively referred as "Indirect Tax") read with Rules, Circulars, and Notifications



- I. Special tax benefits available to the Company
- a. Refund under GST Act- Refund on account of export of goods under payment of integrated tax –with reference to Sec. 16(3)(b) of IGST Act, 2017 Company is claiming refund of Integrated tax paid at the time of export of goods.
  - b. Duty drawback under Customs Act - Drawback on Imported goods where import duties has been paid/ indigenous goods where local duties/taxes has been paid Used in the Manufacture of Export Goods – As per Section 75 of Customs Act, 1962. Company is claiming drawback of such import duties or such local duties or taxes paid on materials which are used in the manufacturing of exported goods.
  - c. Remission of Duties and Taxes on Exported Products (RoDTEP) as per Foreign Trade Policy 2015-2020 for exports of goods– Company is claiming rebate under RoDTEP Scheme at a certain percentage on Freight on Board (FOB) value of exports.
  - d. Advance Authorization (License/Scrip) as per Foreign Trade Policy 2015-2020– Company is claiming the benefit of Advance authorization/license for duty free import of inputs, which are physically incorporated in export products.
  - e. Till Dec, 2020, the Company has claimed MEIS as per Foreign Trade Policy 2015-2020.
- II. Special tax benefits available to Shareholders
- There are no Special Indirect Tax Benefits available to the shareholders for investing in the shares of the Company
- III. Special tax benefits available to Material Subsidiaries
- There are no Special Indirect Tax benefit is available to subsidiaries of the Company

Notes:

1. The above Statement of Indirect Tax benefits sets out the special tax benefits available to the Company, its subsidiaries and its shareholders under the Indirect Tax laws mentioned above.
2. The above Statement covers only above-mentioned tax laws benefits and does not cover any Income Tax law benefits or benefits under any other law.
3. This Statement is intended only to provide general information to the investors and is neither designed nor intended to be a substitute for professional tax advice. In view of the individual nature of tax consequences, each investor is advised to consult his/her own tax advisor with respect to specific tax consequences of his/her investment in the shares of the Company.

No assurance is given that the revenue authorities/courts will concur with the views expressed herein. Our views are based on the existing provisions of law and its interpretation, which are subject to changes from time to time. We do not assume responsibility to update the views consequent to such changes.

**For, Tega Industries Limited**

**For, S D T & Co.,  
Chartered Accountants  
ICAI Firm Registration No.: 112226W**

**Authorised Signatory**

**Dilip K. Thakkar  
Partner  
Membership No.: 031269**

## Annexure B

The quantum of special tax benefits of Income Tax Act, 1961 available to the Company

Rs. million

Fiscal Year	Relevant provisions of the Income Tax Act, 1961				Total	Total Income as per Restated Financial Statement	% of Total Income
	115BA A	80IA	10AA	80JJAA			
Fiscal 2019	-	48.49	152.36	1.03	201.88	6,430.13	3.14%
Fiscal 2020	-	48.86	222.30	0.85	272.01	6,955.42	3.91%
Fiscal 2021	-	-	-	0.85	0.85	8,566.84	0.01%
Three months period ended June 30, 2021	-	-	-	-	-	1,793.86	NA

Notes:

1. Above mentioned figures are as per Income Tax Audit Report for the Fiscal 2019 and Fiscal 2020.
2. The tax benefits for Fiscal 2021 are based on the representation of the management and audited restated financial statements of the Company.
3. Tax benefits are pertaining to complete fiscal year as per provisions of Income Tax Act, 1961 hence any special tax benefit for the period of three months period ended June 30, 2021 cannot be ascertained.
4. The above annexure is prepared by the Company and initialed by us for identification purpose only on specific request by the Company.

**For, Tega Industries Limited**

**For, S D T & Co.,  
Chartered Accountants  
ICAI Firm Registration No.: 112226W**

**Authorised Signatory**

**Dilip K. Thakkar  
Partner  
Membership No.: 031269**

## SECTION IV: ABOUT THE COMPANY

### INDUSTRY OVERVIEW

Except as otherwise indicated, the information contained in this section is derived from a report titled “Global Market Assessment – Select Mineral Processing Equipment” dated October 12, 2021, prepared by F&S. Industry sources and publications generally state that the information contained therein has been obtained from sources generally believed to be reliable, but their accuracy, completeness and underlying assumptions are not guaranteed and their reliability cannot be assured. Industry publications are also prepared based on information as of specific dates and may no longer be current.

### GLOBAL ECONOMY

The global economy was restrained in 2019 by global trade wars, with the COVID-19 pandemic causing a 3.3% contraction in 2020. Governments and central banks across the world rolled out significant fiscal stimulus measures and pursued loose monetary policies to support economies through the recession of 2020. Global growth is expected to accelerate to 5.6% in 2021 and be partially supported by the low GDP base effect from 2020.

Exhibits 1 and 2 are Frost & Sullivan baseline scenario forecasts. The baseline scenario assumes a vaccination rate of 50%–80% across major emerging and developing economies and advanced economies (considers only population that is willing to take the vaccine), and new COVID-19 breakouts in a few countries in H1 2021.

**Exhibit 1: Annual Real GDP Growth Forecast Global, 2015–2025**

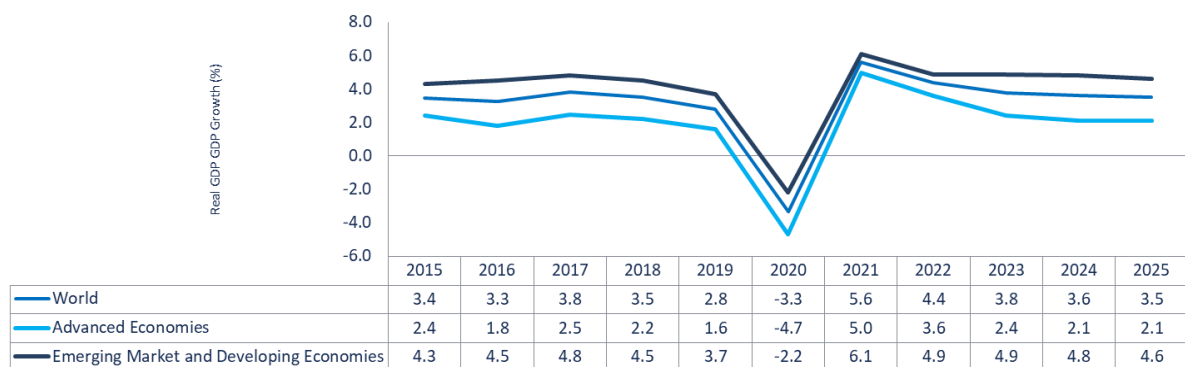

Note: Estimates for 2020 and 2021, with forecasts thereafter. Data stands updated as on 7 May 2021. Source: IMF; Frost & Sullivan

Owing to two new stimulus packages approved between Q4 2020 and Q1 2021, a strong vaccination program, demand-side revival, and near-zero interest rates, the growth of the US economy will surpass 6% in 2021. China’s recovery which began in 2020 will ensure growth of 8.3% in 2021. China’s manufacturing sector, however, may suffer setbacks, as multinational firms relocate production to sites outside the country, following the trade wars and the pandemic. Chile is expected to see 5.8% growth in 2021. Stronger copper prices will be the top growth driver for Chile.

**Exhibit 2: Annual Real GDP Growth Forecast, US, China, Chile, Australia, Russia, 2015–2025**

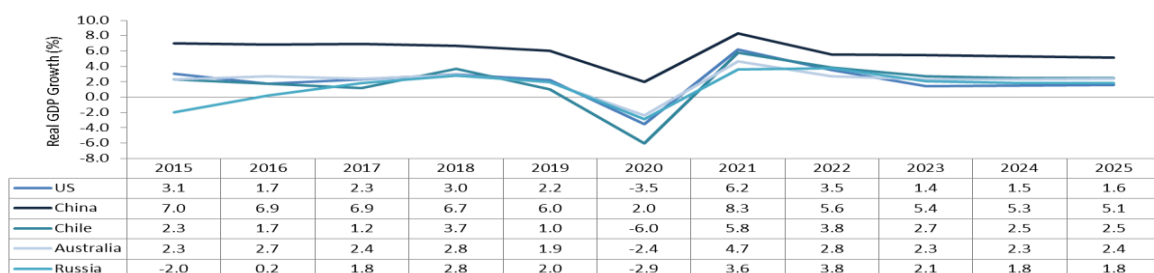

Note: Estimates for 2020 and 2021, with forecasts thereafter. Data stands updated as on or prior to 7 May 2021; Source: IMF; Frost & Sullivan

## Inflation

Global inflation declined in 2020 amidst the pandemic, and the slide could be attributed to factors, such as lockdowns, weaker consumer confidence, and job losses. Global inflation should pick up in 2021 in tandem with higher expected levels of economic activity.

**Exhibit 3: Annual Inflation, Global, 2015–2025**

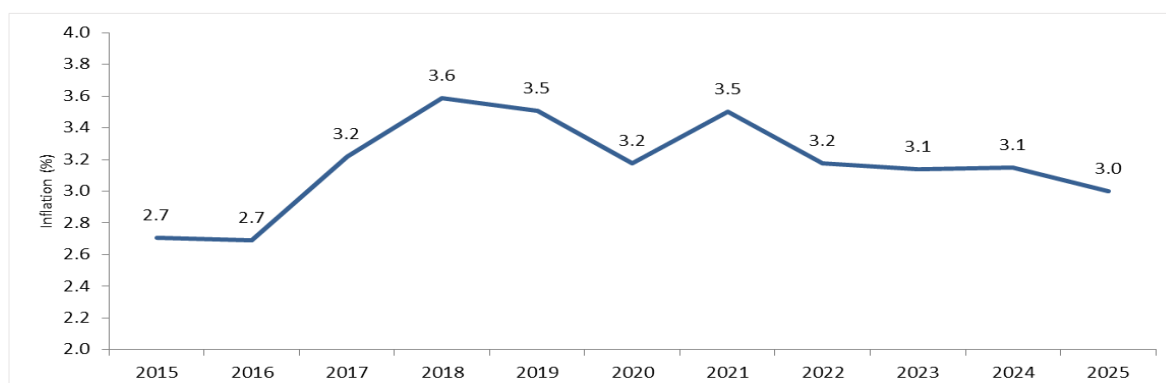

Note: Estimates for 2021; forecasts thereafter. Data stands updated as of April 2021. Source: IMF; Frost & Sullivan

## INDIAN ECONOMY

Indian economy had been witnessing a slowdown in growth, with real GDP growth weakening to 4.0% in 2019–2020. COVID-19 and its associated impact caused a 7.3% contraction in the Indian economy in 2020–2021.

Going into 2021–2022, India’s growth prospects were quite strong based on the scenario in Q1 2021. Frost & Sullivan mid-March forecasts pointed to 11.3% growth for the Indian economy in 2021–2022. The onset of the second wave has, however, weakened India’s 2021–2022 growth prospects, with growth now forecast at only 9.3%. This downward revision in growth is influenced by regional lockdowns and weak progress in vaccination.

**Exhibit 4: Annual Real GDP Growth and Real GDP, India, 2015–2025**

Indicator	2015–2016	2016–2017	2017–2018	2018–2019	2019–2020	2020–2021	2021–2022	2022–2023	2023–2024	2024–2025
<b>Real GDP Growth (%)</b>	8.0	8.3	6.8	6.5	4.0	-7.3	9.3	11.2	6.7	6.9
<b>Real GDP (Rupees Lakh Crore)</b>	113.7	123.1	131.4	140.0	145.7	135.1	147.7	164.1	175.1	187.1
<b>GDP CAGR (%)</b>	2015–2020 CAGR: 6.4					2020–2025 CAGR: 8.5				

Note: Estimates for 2021/22, with forecasts thereafter. Data stands updated as on 23 June 2021. Source: Ministry of Statistics and Programme Implementation; Frost & Sullivan

**Exhibit 5: Annual Real GDP Growth, India, 2015–2025**

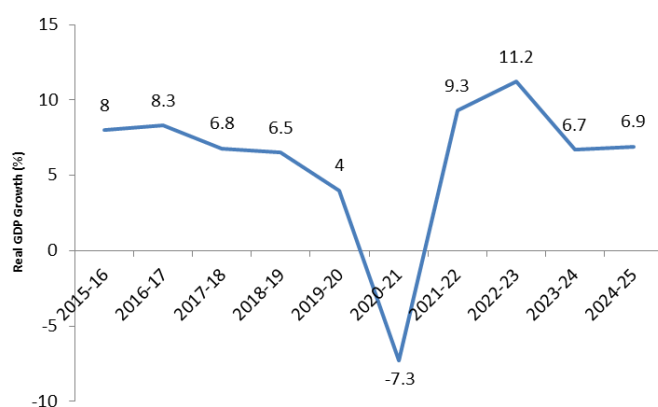

Note: Estimates for Q1 2021–Q4 2022, with forecasts thereafter. The quarterly figures are annualized quarterly growth rates. Data stands updated as on 23 June 2021. Source: Ministry of Statistics and Programme Implementation; Frost & Sullivan.

## OVERVIEW OF THE MINING INDUSTRY

### Global Mining Industry

In 2020, Asia-Pacific accounted for 71% of the global mining industry, followed by North America with 9%. The mining market consists of companies (organizations, sole dealers, and partnerships) that harvest rocks, commodities, and other useful resources (ferrous and nonferrous metals, sand and gravel, coal, and so on) from the Earth’s crust. BHP Billiton Ltd, Glencore Plc, Vale SA, Rio Tinto Group, and CRH Plc are the leading participants in the mining industry.

Global commodity mineral production during 2020 was 10.2 billion tons, with coal and Iron (2 largest minerals mined worldwide) accounting 96% of total production. Silver is the most mined precious metal accounting for 86% of total precious metal mined and is found close to Zinc deposits, while Gold is found mostly near copper mines.

**Exhibit 6: Global Key Commodity Minerals Production (Million Tons)**

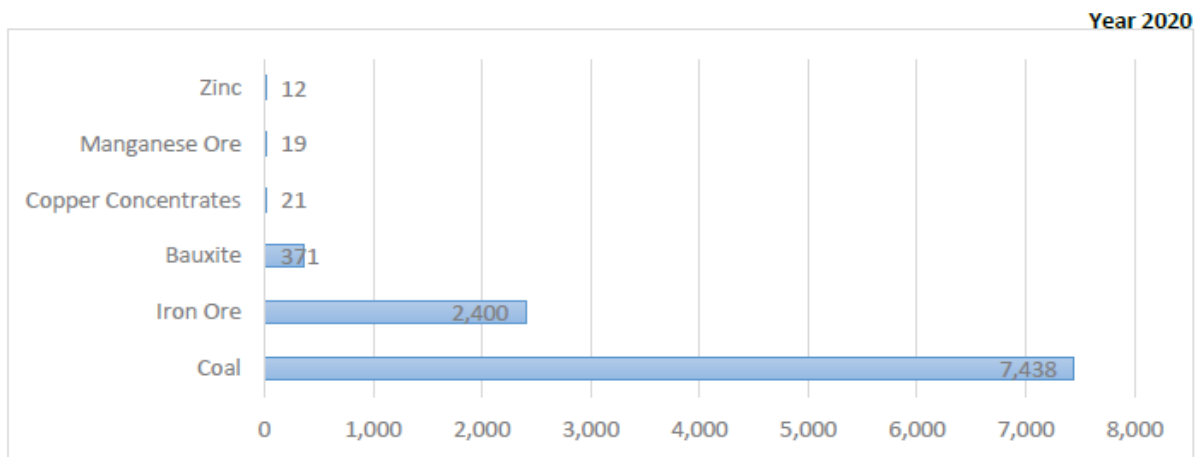

Source: ICSG, USGS; IEA

**Exhibit 7: Global Key Precious Minerals Production (Tons)**

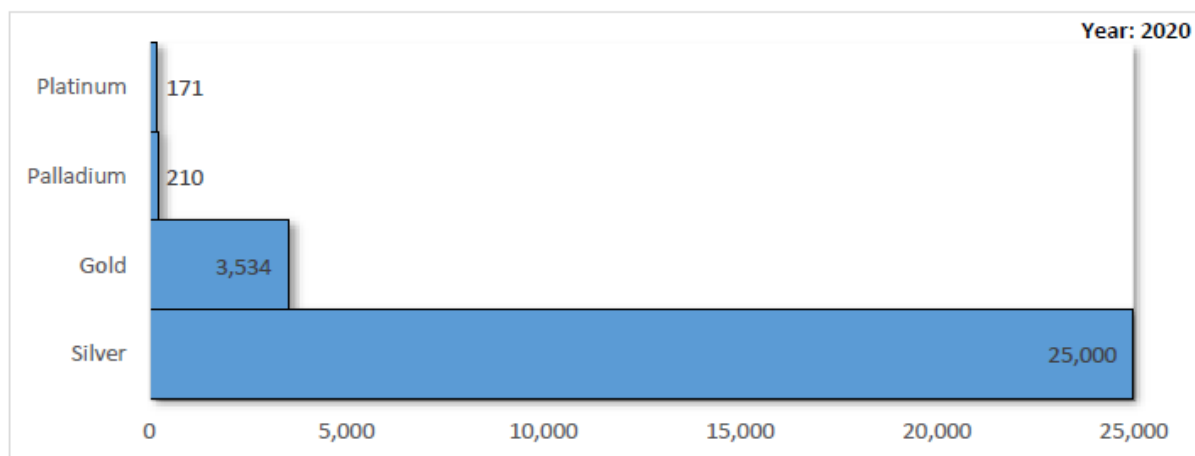

Source: World Gold Council; USGS

**Exhibit 8: Global Iron Ore Production by Country (Million Tons)**

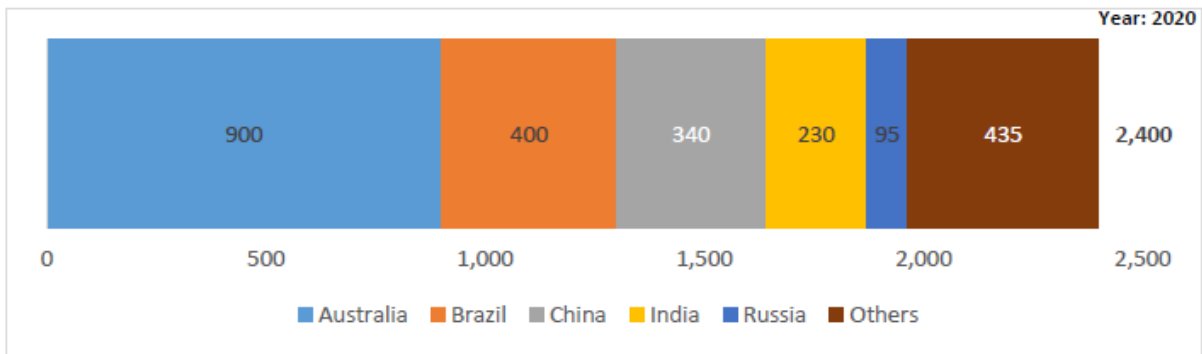

Source: USGS

**Exhibit 9: Global Copper Concentrates Production by Country (Million Tons)**

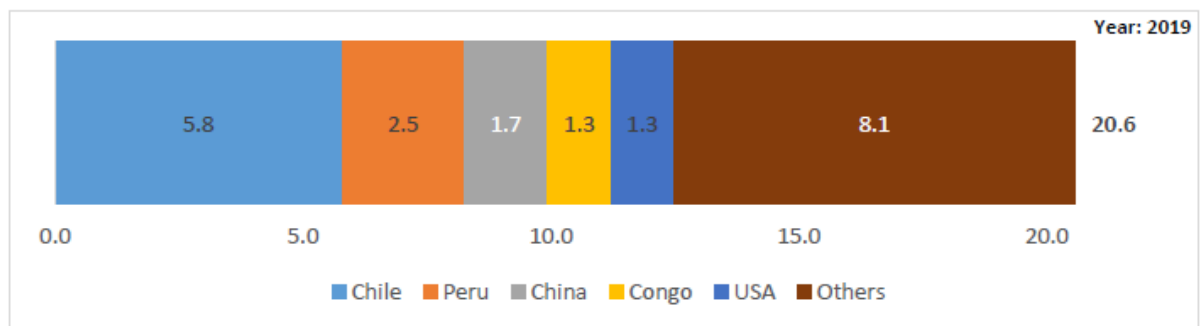

Source: ICSG

**Exhibit 10: Global Zinc Production by Country (Million Tons)**

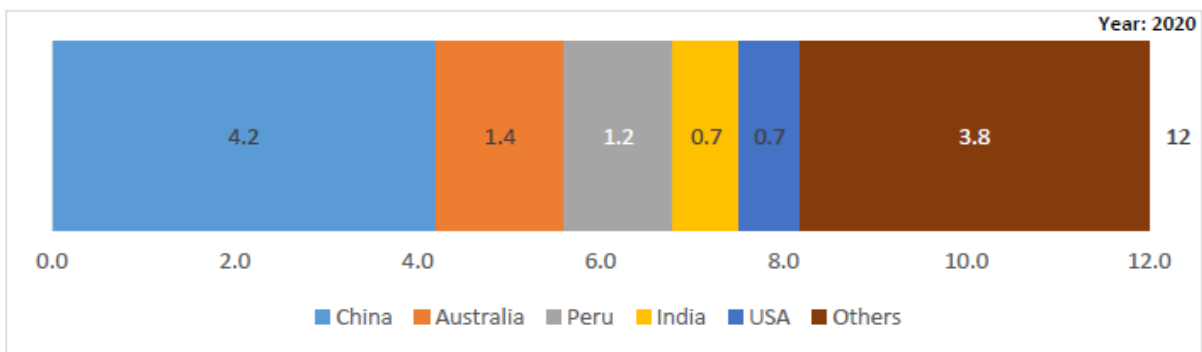

Source: USGS

**Exhibit 11: Global Gold Production by Country (Tons)**

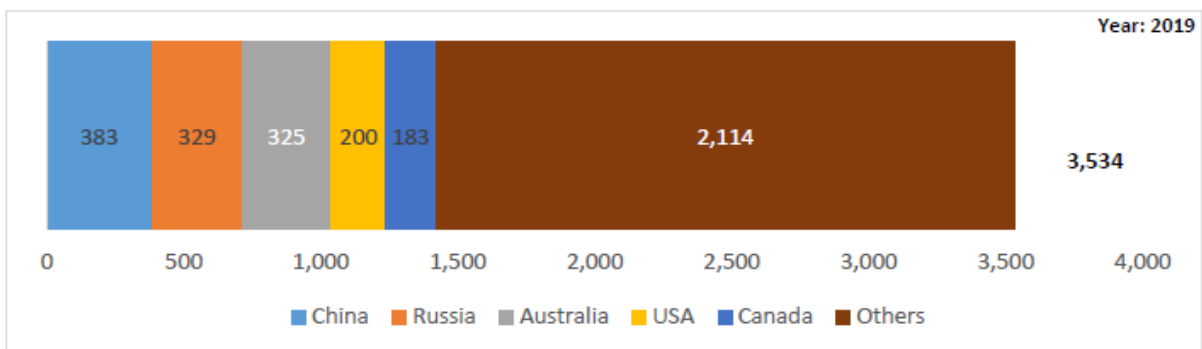

Source: World Gold Council

## Indian Mining Industry

### GDP Contribution

The GDP contribution of the mining and quarrying sector, both in terms of nominal and real GDP, has declined over the last decade. In regards to nominal GDP, as can be seen from the chart below, the share of mining and quarrying declined from 2.13% in 2015–2016 to 1.75% by 2019–2020; the goal of the government is to raise the share from 1.75% to 2.50% (*The Hindu; Financial Express; India Today*). A timeline for this 2.5% commitment, however, is not clear, with 2024–2025 assumed as the timeline, in line with the government’s 2024–2025 vision of becoming a \$5 trillion economy.

For a global comparison of mining shares, Australia’s mining sector, for example, accounted for 11.1% of the country’s nominal gross value-add for 2019–2020. In South Africa, the mining sector accounted for 7.2% of the country’s 2019 real GDP (*Australian Bureau of Statistics; Statistics South Africa*). These figures are reflective of a larger mining sector contribution in these two economies.

### Exhibit 12: Mining and Quarrying Contribution to Nominal GDP, India, 2015–2025

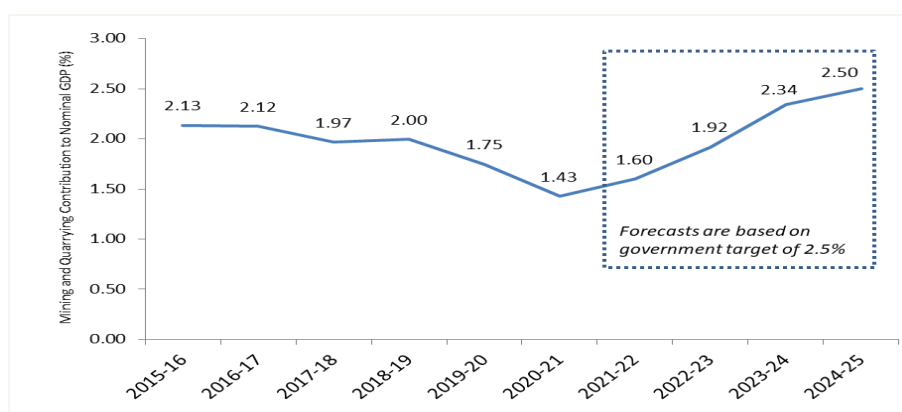

Note: Estimates for 2021–2022, forecasts thereafter; Source: Ministry of Statistics and Programme Implementation; Frost & Sullivan.

## KEY TRENDS IN THE MINING INDUSTRY

### Global Macroeconomic Trends & Developments related to copper and gold mining industries

#### Demand-side Drivers

- **Growing Global Shift toward Renewables to Drive Demand:** While the shift toward renewables has been gaining momentum over the last few years, efforts to reduce emissions appear to have gathered pace following the outbreak of the pandemic. Even in an oil-reliant nation such as Saudi Arabia, the government’s goal is to generate 50% of power from renewables by 2030. This growing shift toward renewables will boost the global demand for copper.
- **US Electric Vehicle Policies to Drive Copper Demand:** President Joe Biden’s push toward higher electric vehicle (EV) production will boost the demand for metals used in EVs, primarily copper. Mines that yield EV metals may not be subject to the strict standards applicable to other mines.
- **South Africa Gold Mining Industry Benefitting from Safe-Haven Demand, Higher Metal Prices:** Gold mining in South Africa, after a long period of decline, has benefitted from the pandemic-driven increase in gold prices. The demand for gold, a safe-haven investment amidst global turmoil, helped lift prices.

#### Supply-side Drivers

- **Long-term Gold Price Rise Driven by Production Shortages; Near-Term Copper Price Rise:** Frost & Sullivan expects gold prices to rise to \$2,500 to \$2,800 by 2030, with expected deficiencies in production. Reduced production from South Africa, in particular, will be a key contributor to the forecast

period price rise. Copper prices are expected see growth in post-pandemic 2021 and 2022 with expected stabilization thereafter.

- **Declining Ore Grades:** Miners have to engage in mining activities to locate concentrates, as ore grades are declining, particularly copper. Lower ore grades are expected to drive higher CapEx investments within the industry.
- **Extension of the Decline in Chilean Copper Production into Q1 2021:** Amidst the pandemic, Chile, the world's largest copper producer, witnessed a decline in copper production for the 10<sup>th</sup> straight month in March 2021. Maintenance activities and weaker ore grades also contributed to the decline.
- **Proposed Royalty on Chile Copper and Lithium Sales:** The Congress in Chile had been discussing a proposed flat 3% royalty on copper and lithium sales, with eventual discussions on additional marginal tax rates of 15%–75%, depending on higher copper prices and associated additional sales (*BNamericas; Financial Times*).

## Macroeconomic Trends & Developments in India

**Indian Mining Structural Reforms 2021:** The 2021 approval of the Mines and Minerals (Development and Regulation) Amendment Bill should help pave the way for increased domestic production and curtailed imports, increased private sector participation, and higher mining employment. The bill, for example, facilitates the re-allotment of mining blocks facing legacy cases through means of auctions. Another reform is in regard to captive mines for which end use was previously restricted to the mine leaseholder. The provision now opens up the sale of 50% of the mineral production to the open market, with 50% of the production to be used in the company plant.

**Opening Up for Commercial Coal Mining:** In 2020, the government fully allowed for commercial coal mining, essentially allowing private players to enter into coal mining and sales. No restrictions were placed on the end use of the coal (that is, the coal could be used in plants or sold in markets). 19 coal mines were awarded through auctions in 2020, with another 67 coal mines put up for auction in March 2021 (*Financial Express; The Hindu Business Line*). The government views coal as a pivotal contributor to the vision of becoming a \$5 trillion economy.

**Targeted Tripling of Gold Production:** The goal of Hutti Gold Mines Limited, India's sole gold producer and owned by the state government of Karnataka, is to nearly triple gold production from 1,700 kilograms/annum in Q1 2021 to 5,000 kilograms/annum by mid-2021 (*Financial Express*). In tandem with the targeted production increase, the Karnataka government is looking to establish jewelry stores with the support of private sector tie-ups, which should help drive gold demand.

## Government Spending Plans

The government's priority spending plans for the next five years have been detailed below.

**\$1.5 Trillion (₹111 Lakh Crore) under National Infrastructure Pipeline:** Infrastructure is set to help India become a \$5 trillion economy by the fiscal year 2024–25 (*Financial Express*). The National Infrastructure Pipeline entails \$1.5 trillion in infrastructure expenditure (fiscal year 2020–2025), with the central and state governments undertaking 79% of the capital expenditure (the remaining being private expenditure) (*Task Force on National Infrastructure Pipeline*). Energy and roads account for 24% and 18% of CapEx, respectively (*Task Force on National Infrastructure Pipeline*). As of December 2020, 40% of the projects under the National Infrastructure Pipeline were reported to have been under implementation (*Task Force on National Infrastructure Pipeline*).

**Target of Raising Public Healthcare Spending Share to 2.5% of GDP:** The Indian government's expenditure on health was 1.6% of GDP during the 2019–2020 period and similar to the preceding years. In contrast, the figure for the European Union was 7.0% of GDP for 2019 (*Press Information Bureau, Government of India; Eurostat*).

**\$26.9 Billion (₹1.97 Lakh Crore) on Production-Linked Incentive (PLI) Schemes:** Introduced in 2020, the PLI schemes entail an incentive tied to incremental sales from domestic manufacturing. The scheme is expected to be a major driver in attracting global supply-chains and fortifying India's manufacturing position over the next five years (2021–2025). The government expects to generate \$520 billion in new manufacturing from PLI over the next five years (*The Economic Times*).



## REVIEW AND OUTLOOK OF THE MINERAL PROCESSING INDUSTRY

The ore occur in large lumps which is broken on desired size using crushers, screens and other mineral processing equipment. The mineral processing value chain after mining the ore to floatation requires various mineral processing equipment such as chutes, grinding mills, trommels and screens, hydrocyclones, pumps, floatation parts and conveyors. The surface of these equipment is subjected to high impact, sliding abrasion and corrosion. To protect these equipment, have a longer service life, reduce the downtime and reduce the noise levels during the operation it is very critical to install reliable products called liners in these equipment which can withstand the sliding abrasion. The science and engineering of these interacting surfaces in relative motion called “Tribology”. The combination of mineral processing engineering, mechanical engineering and material science provide products that extends the service life of the equipment in use, reduce the down time as well as the operating expense.

### Exhibit 13: Mineral Beneficiation Industry

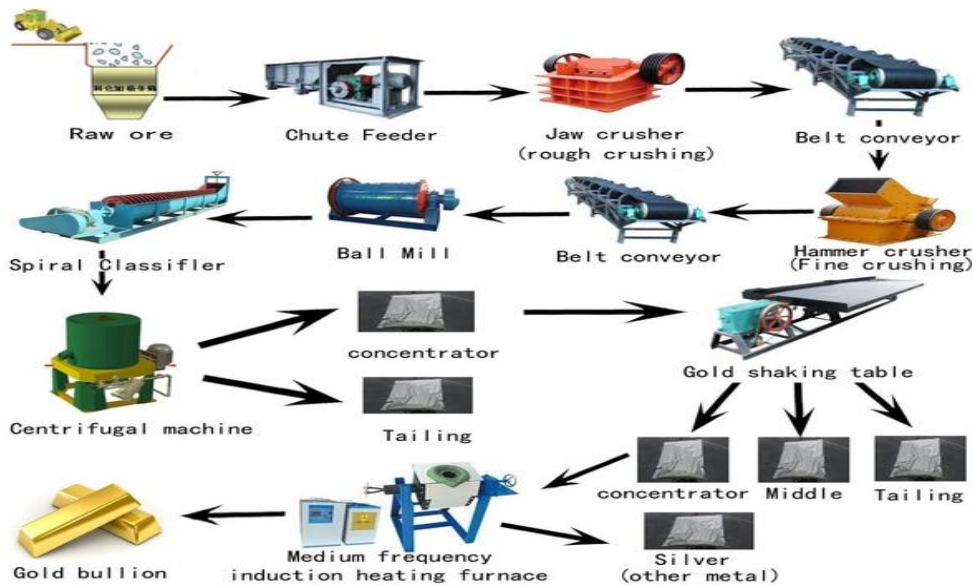

Image Source: Gold Mining Process, Henan Hongxing Mining Machinery Co., Ltd.

**Crushers:** Crushers are machines primarily used to reduce the size of rocks, stones, and ore and are widely used in mining operations, aggregates production, and construction material recycling.

**Screening:** Screening is used to separate the granulated ore into multiple grades by particle size. Screens can be horizontal, rotary, or vibrating; based applications, they are further classified into dewatering screens, grizzly screens, single- and double-deck linear screens, and banana screens.

Screening is also known as comminution, a process by which ore is further reduced to minute particles; this is followed by sizing, concentration, and dewatering.

1. Comminution: particle size reduction
2. Sizing: separation of particle sizes by screening or classification
3. Concentration by physical and surface chemical properties
4. Dewatering: solid/liquid separation

### Concentration

Different mineral properties required different mineral processing methods. The common ore dressing methods are gravity concentration, flotation, magnetic separation, electric separation, chemical dressing, and so on.

1. **Gravity beneficiation** or gravity concentration is the process of separating minerals as per the density and velocity of the medium.

2. **Flotation** is a mineral processing method that uses the various physical and chemical properties of mineral surface to separate minerals.
3. **Magnetic separation** is the key process in iron ore beneficiation, especially magnetite ore and manganese ore. Magnetic separation is also widely used in the processing of nonferrous and rare metal ores.
4. **Electric Beneficiation** uses high-voltage electric field to separate the particles. This method is widely used for processing fine- grained minerals.
5. **Chemical Beneficiation** is where various chemical processes are employed to separate mineral particles when physical separation processes do not work.

### Overview of the Global Mineral Processing Industry

Global crushing, screening, and mineral processing equipment market size was estimated at \$20 billion in 2020. The market was growing at a CAGR of about 7% until 2019 but due to the COVID-19 pandemic, the overall demand declined in 2020. The industry is likely to recover in 2022 and is forecast to reach \$36.9 billion by 2030, growing at a CAGR of 6.3%.

**Exhibit 14: Global Mineral Processing Industry Market Size (Million Tons)**

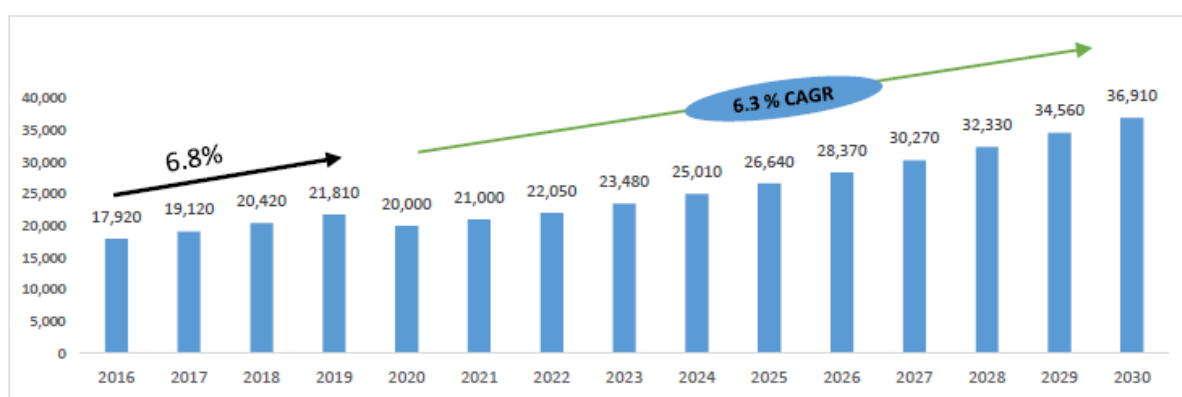

Actuals (2016–2020). Source: Frost & Sullivan

The demand for iron ore, copper, and other metals and minerals will drive the growth of the mineral processing equipment industry, while electric vehicle manufacturing will be the top demand driver for copper, aluminum, and other metals. Owing to ore grade depletion, miners are required to process more ore to get the desired yield, which will boost the demand for mineral processing equipment.

### Global Mining CapEx Overview

#### Global Overview

CapEx spending for metal ores, such as copper, gold, iron ore, coal, nickel, zinc and others during 2019 was estimated to be \$85 billion. CapEx spending of copper and gold was \$50–\$55 billion; this accounted for more than 60% of the global mining CapEx spending. Copper individually accounted for \$30–\$35 billion and gold reported spending of \$20–\$25 billion. Iron ore mining is a more mature industry, and CapEx spending has reduced over the last 4 or 5 years; the iron ore industry is now further impacted by scrap recycling which is gaining traction in the global market globally. Similarly coal is also a mature industry, and countries are cutting down on coal consumption, especially in power sector, and the focus has shifted toward clean fuel consumption, such as nuclear and renewable resources. As nickel and zinc are rare metals, their CapEx spending was low (*CAPEX S&P Global*).

#### COVID-19 Impact in Mining CapEx

Due to the COVID-19 pandemic the mining CapEx dropped significantly in 2020. Frost & Sullivan expects recovery in CapEx spends in copper and gold during 2021 and also in the near term (4–5 years)

COVID-19-related closures had a dual impact on the mining industry. The first was around temporary mine closures and a limited workforce operating in the mines, which led to lower CapEx spending. The second was the operational challenge related to lower utilization postponement/delay in mining activities.

## Future Impact

Demand for copper is expected to grow in future with the higher EV production and industry automation (Industry 4.0) worldwide. Electronics and consumer durables will continue to be key contributors to copper demand. Production of gold is also expected to grow as Russia increases its mining capacity and overtakes China in the near future.

## Global Copper Mining Industry Overview

The world's copper metal reserves are estimated to be 870 million tons of copper content. Chile has the highest share, accounting for about 23% of global assets, led by Australia and Peru with 10% each; Russia, 7%; Mexico and the United States, 6% each; and Indonesia and China, 3% each.

Owing to the COVID-19 pandemic, global mine supply of copper fell marginally to an estimated 20 million tons in 2020, down from 20.4 million tons in 2019.

## Global Copper Concentrate Production Forecast, 2016–2030

Exhibit 15: Global Copper Concentrate Production (Million Tons)

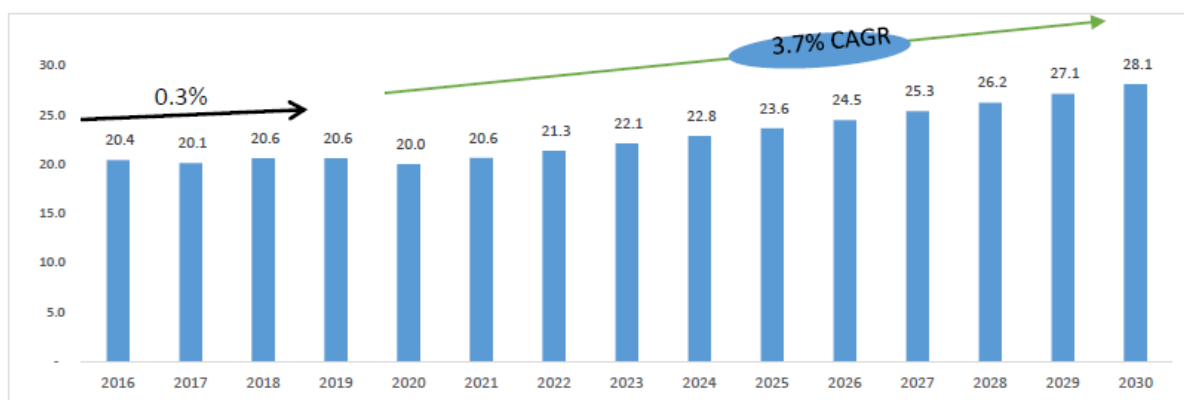

Actuals (2016–2019); Source: ICSG; USGS; Frost & Sullivan

Over the last decade, global copper concentrate production had increased by a CAGR of 2.4%, primarily from China and Peru. China had increased its production during 2012 to 1.5 million tons because of higher domestic demand from the electronics sector; China is still one among the largest importers of copper concentrates in the world. Peru, during the 2015–2016 time period, doubled its copper concentrate production capacity. Copper production is expected to decline by about 2% worldwide due to the impact of the COVID-19 pandemic in 2020.

## Overview of Top Global Copper Producers

**Chile:** Chile is the most powerful player in the copper mining industry in many ways, as it has the highest deposits in the world, and copper production constitutes 90% of the country's exports. Chile's copper mine production was projected to be 5.79 million metric tons of metal content, accounting for 28% of the global output.

**Peru:** Peru is the second largest and one of the most lucrative mining countries in South America. Peru's copper supply increased more than 97%, between 2008 and 2019. Peru's government had set a target to double copper production by 2016 to reclaim its status as the world's second-largest copper producer after Chile.

**China:** China is the world's largest copper-consuming economy. Though the country's small copper ore deposits are mined, it imports that meet more than 60% of the domestic demand. Copper mine Concentrate production increased marginally from 1.56 million metric tons in 2018 to 1.68 million tons in 2020.

**Congo:** The large high-grade copper deposits in this nation are remarkable; some mines are expected to have grades above 3%, considerably higher than the global average of 0.6% to 0.8%, but there are also significant political and security challenges exacerbated by the shortage of robust infrastructure.

**US:** In 2020, recoverable copper mine production in the United States was 1.2 million tons. Arizona was the leading copper-producing state, accounting for roughly 74% of domestic output. Copper was recovered or refined (18 of which accounted for 99 percent of mine production) at 25 mines.

**India:** Copper reserves are estimated to be 207.77 million tons (13.8%) while 1.30 billion tons (86.2%) are categorized under remaining resources. Rajasthan has the most copper ore reserves/resources, accounting for 53.8% (or 813 million tons), followed by Jharkhand, 19.5%; and Madhya Pradesh, 18.8%. Vedanta and Hindalco import copper concentrates, while Hindustan Copper Limited (HCL) is India’s sole copper mining business. In 2018–2019, copper ore output increased by 12% to 4.13 million tons, up from 4.12 million tons the previous year. Singhbhum Copper Belt, Malanjkhand Copper Belt, and Khetri Copper Belt are the three regions where Hindustan Copper Ltd operates mines. With a capital investment of (₹5,500 crore), HCL has formulated a plan to increase mine capacity ranging from 3.8 to 20.0 million tons per annum over the next six years. Copper demand in India is expected to rise at the rate of 6–7% due to the government’s increased focus on “Make in India” and “Smart City” initiatives.

In 2017, India’s per capita copper intake was 0.6 kg, which is very poor when compared to countries, such as Russia, 3.3 kg; China, 5.4 kg; the United States, 5.5 kg; Italy, 8.9 kg; and Germany, 13.6 kg. According to the International Copper Study Group (ICSG), the electrical and telecommunication industry accounts for 56% percent of overall demand, followed by transportation, 8%; consumer durables, 7%; building and construction, 7%; general engineering products, 6%; and other sectors such as process industries, 16%.

The top 5 countries account for 60% of global copper production, and Indian mines support about 0.02% of the global production.

#### Exhibit 16: Copper Mine Concentrate Production by Country

Country	Mine Production, 2019 (Thousand Tons, %)	Country	Mine Production, 2019 (Thousand Tons, %)
1. Chile	5,790; 28%	8. Zambia	797; 4%
2. Peru	2,460; 12%	9 Mexico	715; 3%
3. China	1,680; 8%	10. Canada	573; 3%
4. Congo	1,290; 6%	11. Kazakhstan	562; 3%
5. United States	1,260; 6%	12. Poland	399; 2%
6. Australia	934; 5%	13. India	4.13; 0.02%
7. Russia	801; 4%	14. Rest of World	3,235; 16.08%
<b>Total</b>			<b>20,570; 100%</b>

Source: ICSG; Indian Bureau of Mines

#### Exhibit 17: Top 10 Copper Mining Companies

Company	Production ('000 T) 2019	% share
Codelco	1706	18.3%
Glencore	1371	14.7%
Freeport-McMoRan	1170	12.6%
BHP Biliton	1161	12.5%
Southern Copper	994	10.7%
First Quantum	702	7.5%
KGHM	702	7.5%
Rio Tinto	577	6.2%
Antafagasta	491	5.3%
Anglo American	444	4.8%

Source: Kitco.com

#### Depletion of Iron Ore Concentrates

Copper ore concentrates are depleting continuously worldwide, miners must dig deeper to find more concentrates, as ore grades are declining.

### Exhibit 18: Depleting Copper Concentrates

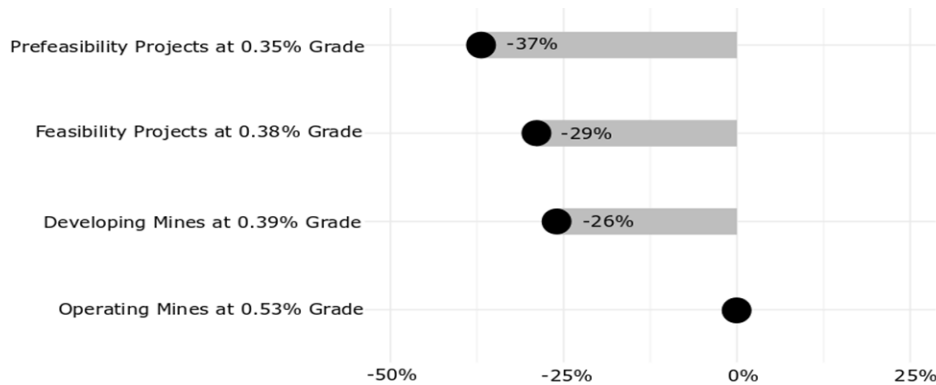

All figures as per actuals; Source: Mining.com

Operational mines are producing about 0.53% of copper concentrates. Newer mines are expected to produce 26% less yield and would only have 0.39% of copper concentrates. A few new mines in feasibility and pre-feasibility stages would have lesser yields of nearly 0.35% of the total excavation.

According to BHP, an Australian-UK resources company, falling grades will reduce by roughly 2 million tons/year of global copper mining supplies, by 2030.

Copper ore is generally available in oxide and sulfide forms. Exhibit 18 shows all forms of copper ore grades are reducing; this is expected to decline in future as well, while the demand for mineral processing equipment will grow.

### Exhibit 19: Depleting Copper Ore Percentage Trend

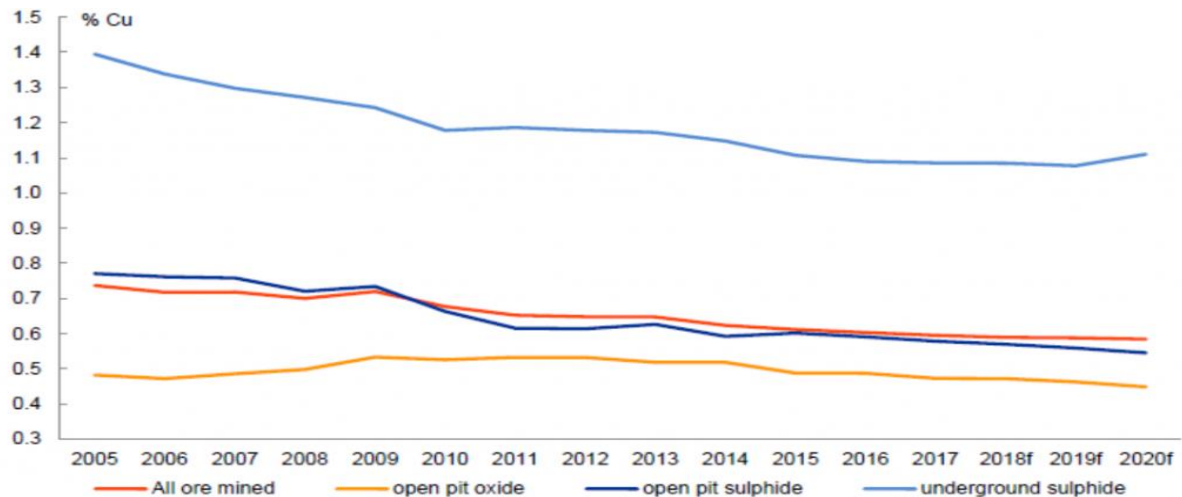

All figures as per actuals; Source: Mining.com.

Copper mill sites also require superior quality of consumables and have higher beneficiation requirements. Ore grades have been declining by around less than 1% per ton, over the last few years, which has led to disproportionate industry growth of around 7% for copper mining and around 5% mineral processing equipment at each mill site. Also, decreasing ore grades has led to a greater demand for larger-sized mills, leading to an 17% growth Year on Year 2020 to 2021 of the mill lining industry.

Frost & Sullivan expects demand for replacement of mill liners to grow at a firm pace as the ore grades are depleting globally, and miners have to dig deeper to find better yields.

### CapEx Spending in Copper

As per S&P Global, CapEx spending in copper industry was estimated at \$30–35 billion in 2019. The demand for copper is growing significantly across world, primarily in electronics, electrical, consumer goods and EV segments.

### Copper LME Index Price Trends (\$/Ton)

Copper stocks have lately decreased and are projected to reduce further in LME which resulted increase in prices.

#### Exhibit 20: Historic Copper LME Index (\$/Ton)

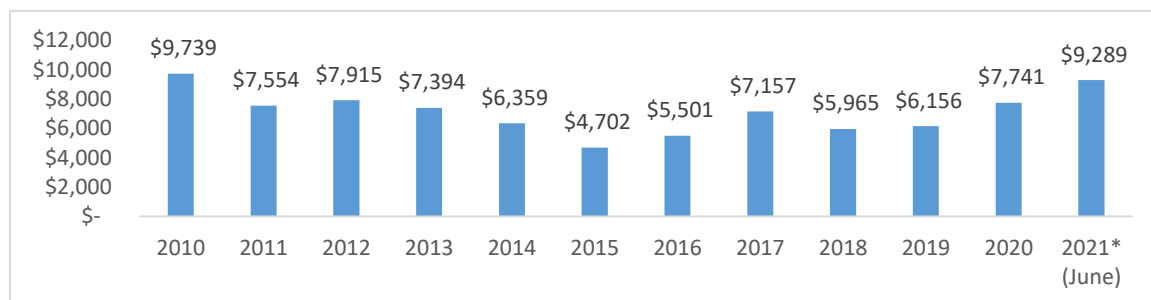

\*Average pricing has been considered until June 2021. Note: All figures are actuals and end-of-year (31 December 2020) price. Source: LME.com

- Q3 and Q4 surge in the LME index can be attributed to recovery in stocks and consumption, as many units resumed production; LME averaged at \$7,755/t by December 2020.
- Copper is mostly procured based on one-month cash average and the previous one-month LME average price.
- Frost & Sullivan expects copper prices to further grow in 2021 and 2022, in the range of \$ 8,000-10,000/ton, and to then stabilize after the demand-supply scenario attains normalcy.

#### Demand Drivers for Copper

- Demand for copper is expected to increase significantly because of global initiatives and trends, such as the development of industrial corridors, smart city projects, and manufacturing of EVs.
- EVs will be one of the key driving factors for copper; a typical pure-battery-powered electric car requires about 80 kilograms of copper, four times the amount used in a traditional vehicle.
- The focus on renewable energy resources, such as solar, hydro, and wind energy, will drive the global demand for copper.

The growth of infrastructure projects, such as railways, airports, and metro rails, will be a key driving factor for copper cables worldwide.

#### Exhibit 21: Global Copper Demand (Mn Tons)

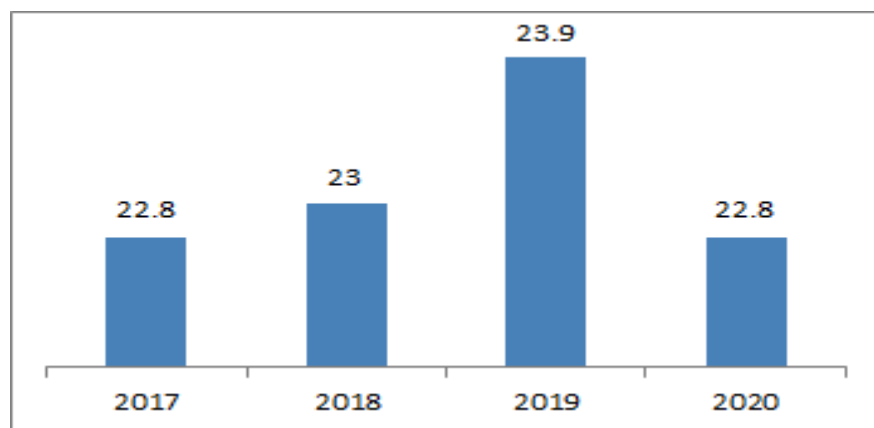

Demand for copper dipped to 22.8 Mn Tons in 2020 from 23.9 Mn Tons in 2019, due to impact of Covid 19 pandemic on the overall industry. For 2021 the copper demand is expected to bounce back to 23.6 Mn Tons

## Global Gold Mining Industry

The world's gold reserves are believed to be about 50,000 tons of metal content. Australia, Russia, South Africa, the United States, Indonesia, Brazil, and Peru have significant gold deposits. Global gold mine output is 3,200 tons, 3% lower in 2020 than it was in 2019. In comparison to the previous year, mine production in Argentina, China, Mali, and Sudan remained stable, although it was marginally lower in Australia, Canada, Ghana, and Russia. The top 5 countries account for 40% of global production, while Indian mines support about 0.02% of it.

## Global Historic Gold Concentrate Production

### Exhibit 22: Historic Gold Concentrate Production (Tons)

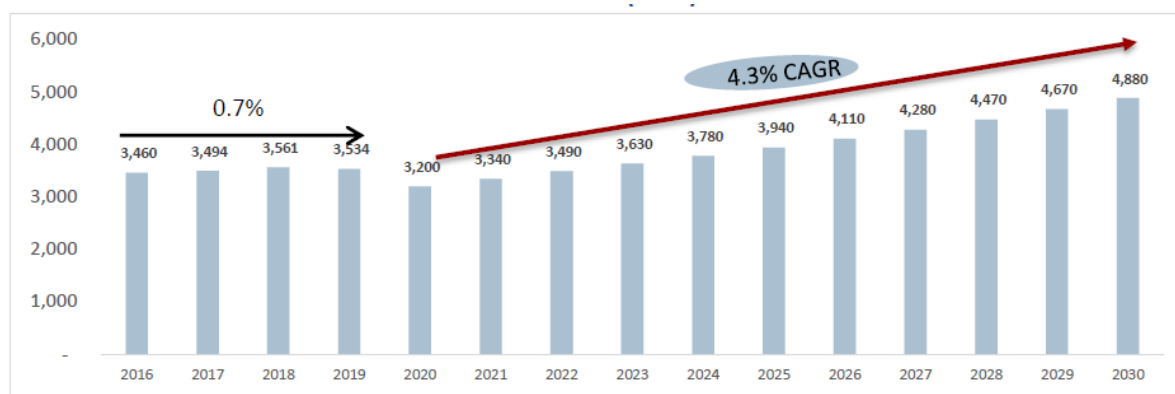

Actuals (2016–2019)

Source: World Gold Council, USGS; Frost & Sullivan

Actuals (2016–2019). Source: World Gold Council, USGS; Frost & Sullivan

Gold concentrate production has been growing due to increased Chinese and Russian mining activities in recent years. However, Australia has the largest gold reserves worldwide, followed by Russia. For decades, South Africa's gold concentrate production has been diminishing. The country's gold production dropped to 90 tons in 2020 from a high of about 1,000 tons in 1970. Gold concentrate production had been growing at a CAGR of 2.6% from 2010 to 2019. A major drop is expected during 2020, primarily due to the impact of the COVID-19 pandemic.

## Overview of Top Global Gold Producers

**China:** China has been the world's leading producer of gold for the last 11 years, surpassing South Africa in 2007. In 2020, China produced 380 tons of gold, accounting for just over 12% of the global demand.

**Australia:** Australia has the world's highest share of economic gold deposits and is also a significant gold exporter. After China, Australia is the world's second-largest gold producer. Western Australia is home to approximately 43% of the world's gold economic wealth. Western Australia produced about 68% of Australia's gold, with New South Wales coming in second at 12%.

**Russia:** Russia is a big participant in foreign markets, producing more than 80% of all European gold. Russia has about 8,000 tons of recoverable gold deposits. To expand its global production share, Russia is investing heavily in exploration and mining activities. In January 2020, trans-Siberian gold found a new zone in the Asacha gold mine, an underground operation in Kamchatka. Growing at a CAGR of 3.7%, Russia is estimated to surpass Chinese production by 2029.

**US:** In 2020, gold mine output in the United States is expected to be about 190 tons, down 5% from 2019, with a value of about \$11 billion. Gold was mined in 11 different states, with Nevada, Colorado, and Alaska being the most productive. Nevada produces about 78% of the gold extracted in the United States. Nearly 7% of domestic gold was recovered as a byproduct of refining domestic base-metal ores (mostly copper ore).

**India:** India produced 1.6 tons of gold in 2020, and its gold reserve is estimated to be 654.74 tons. 70.09 tons were classified as reserves, while 584.65 tons were classified as remaining resources. By states, the largest resources in terms of gold ore (primary) are in Bihar, 44%; followed by Rajasthan, 25%; Karnataka, 21%; and rest of India, 10% (West Bengal, Andhra Pradesh, Jharkhand, Chhattisgarh, Madhya Pradesh, Kerala Maharashtra, and Tamil Nadu). HGML is the only public sector company in the country producing gold in the Raichur district of Karnataka. HGML runs mines at Hutti and Hira- Buddini.



### Exhibit 23: Gold Concentrate Production by Country

Country	Mine Production, 2019 (Tons; %)	Country	Mine Production, 2019 (Tons; %)
1. China	383; 11%	10. Brazil	107; 3%
2. Russia	329; 9%	11. Uzbekistan	104; 3%
3. Australia	325; 9%	12. Indonesia	83; 2%
4. US	200; 6%	13. Kazakhstan	77; 2%
5. Canada	183; 5%	14. Sudan	77; 2%
6. Peru	143; 4%	15. Mali	71; 2%
7. Ghana	142; 4%	16. Argentina	53; 1%
8. South Africa	118; 3%	17. India	1.6; 0.05%
9. Mexico	111; 3%	18. Rest of World	1,026; 29.5%
<b>Total (Tons)</b>		<b>3,534 (100%)</b>	

Source: World Gold Council; Indian Bureau of Mines

### Exhibit 24: Top 10 Gold Mining Companies

Company	Production (MOz) 2019	% share
Newmont	6.29	21.7%
Barrick	5.47	18.9%
Anglo Gold Ashanti	3.28	11.3%
Polyus	2.84	9.8%
Kinross	2.51	8.7%
Gold Fields	2.2	7.6%
Newcrest	2.35	8.1%
Agnico Eagle	1.78	6.1%
Polymetal	1.32	4.6%
Kirkland Lake	0.97	3.3%

Source: Kitco.com

### Global Historic Gold Ore Depletion

Lower ore grades have a major influence on production costs; hence, gold grade is a key profit driver for a mine. A reduction in gold grades caused a significant increase in cash expenses for the world's biggest gold miners. Gold reserves are in limited quantity globally by which miners have to excavate more to find suitable yields.

### CapEx Spending in Gold

As per S&P Global, Gold is the next major industry, after copper, to entail high CapEx investments. In 2019, about \$15–20 billion was invested in gold mining operations. Frost & Sullivan expects demand to grow significantly, as ore grades have depleted, and new, emerging participants in Russia will explore more mines.

### Gold Pricing Trends LME (\$/oz)

#### Exhibit 25: Historic Gold Prices Based on LME (\$/oz)

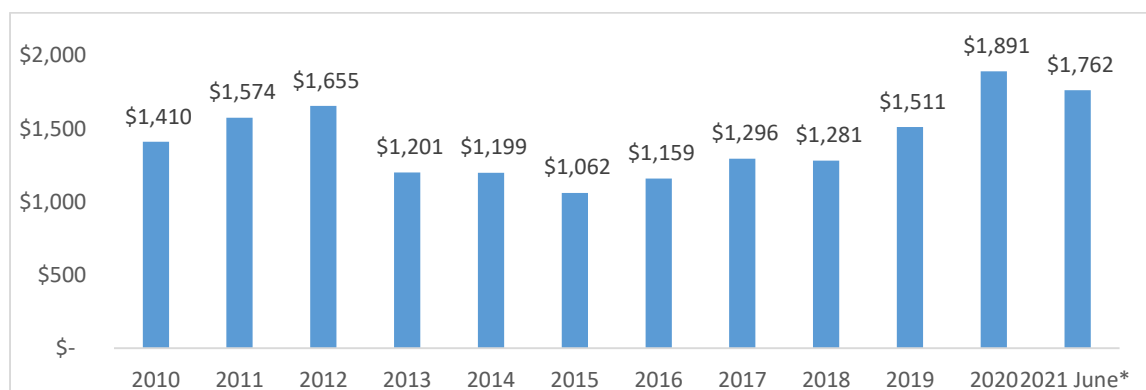

All figures in actuals; Source: LME.com. \*Average pricing has been considered until June 2021; Note: All figures are actuals and end-of-year (31 December 2020) price. Source: LME.com

- Prices stabilized after post-lockdown production resumed worldwide.



- Frost & Sullivan expects the gold prices to further stabilize in 2021 and 2022, in the range of \$1800–1900/oz, and then would stabilize post the demand and supply scenario attains normalcy.

### Demand Drivers for Gold

Purchasing of gold is considered ‘safe’ from economic failures. Gold used in jewelry accounts for roughly 80% of the demand; the rest is produced as blocks and coins. The electronics industry has contributed to the recent rise in demand for gold because of its high conductivity.

As the global demand-supply gap for gold widens and the production from South Africa decline, Frost & Sullivan expects prices to rise by about \$2,500 to \$2,800 by 2030.

### Exhibit 26: Global Gold Demand (Tons)

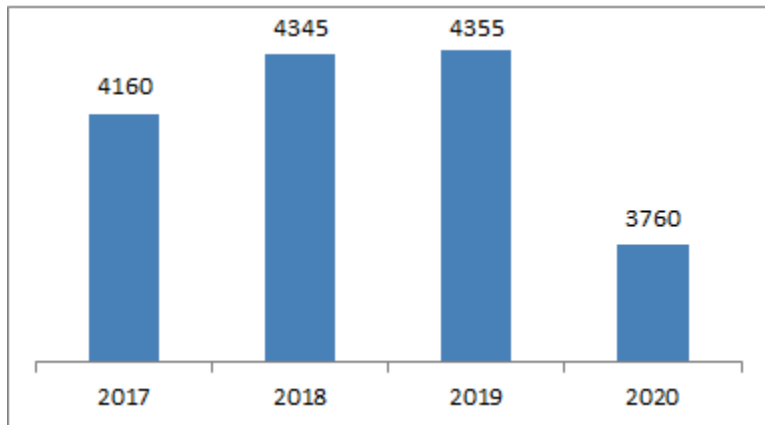

The Global Gold market was impacted hugely in 2020 due to Covid 19 pandemic. The coronavirus pandemic, with its far-reaching effects, was the driving factor behind weakness in consumer demand throughout 2020, culminating in a 14% decline in annual demand to 3,760 tons, the first sub-4,000 Tons per year since 2009.

## REVIEW AND OUTLOOK OF THE GLOBAL MILL LINER INDUSTRY

### Overview

A mill is a machine that grinds, cuts, and crushes solid materials into useable sizes for further processing. Crushed ore is fed into mills where it is ground down to a desired particle size; mills are used widely to processes raw materials in a variety of sectors. Mill liners fundamentally protect mills from the wear that comes with grinding harsh raw materials.

Mill liners are used to improve a mill’s performance, efficiency, and longevity; however, not all mill liners are made equal, even though they all serve the same purpose. Mill liners can be metallic, rubber or composite materials. The type of grinding media as well as the desired output of media is an important consideration in selecting the type of mill liners.

Mill liners are widely used in copper, gold, iron ore (in that order); other mill liners are classified under cement/aggregates and occupy a small share of the market. Copper and gold are key consumers of mill liners, as the mined material is very abrasive; in addition, the yield per ton of ore mined in these two segments is declining due to ore degradation and excess mining in past. Mill liners primarily have a life of 6 months to 2 years, depending on the hardness of the ore to be refined.

Global mill liner market was estimated at \$1.73 billion in 2020 and was largely driven by ore beneficiation in gold and copper worldwide and iron ore in Brazil and China.

### Grinding Mills

A ball mill is used for fine grinding in the horizontal and vertical positions. The mill is filled with steel balls, manganese balls, or ceramic balls. Highly suitable for dry grinding, this machine is used to crush aggregates in the cement industry.

**Autogenous Mill (AG) and Semi-autogenous (SAG) mill** combine two processes, crushing and grinding; the mills use materials themselves as grinding medium; the mutual contact progressively reduces material sizes. AG and SAG are used in both dry and wet grinding applications in either mineral processing or ore beneficiation process.

**Exhibit 27: Mill Liner Industry Value Chain**

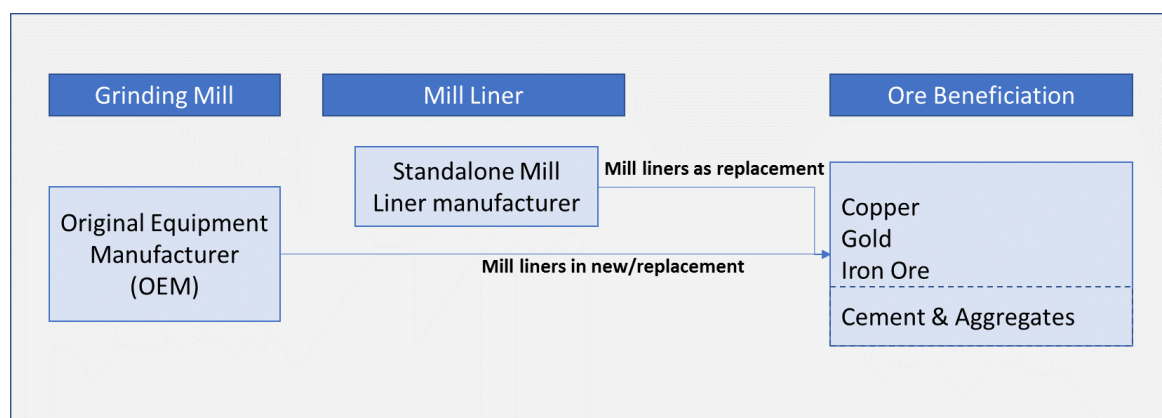

Source: Frost & Sullivan

After-market spend for a mining mill comprises regular operating expenses which include costs of wear and separation parts, grinding media, power consumption, liners and other regular operating expenses.

Ore beneficiation companies procure customized grinding mills and mill liners from OEMs. Once the mill liners are ready for replacement, ore beneficiation companies have the choice to source either directly from OEMs or from stand-alone mill liner suppliers

Though the mill liners are a low cost component in mill’s operations, constituting about 3% -15% of mill’s operating cost, as per one of the past study, based on Morila Gold Mine located in Mali, in which the average yield of gold was 9gms/ton and the average mill tonnage 293 tons per hour. With the price of gold at \$66 per gram the overall opportunity cost per hour of downtime cost per hour could go upto as high as \$174,042. To avoid such a high down time the quality of mill liners is very important.

Average Mill tonnage (A)	Average Gold grade per ton (B)	Price per gram (C)	Opportunity Cost per hour of downtime (A)X(B)X(C)
293 tons per hour	9 gms/ton	\$ 66/ gms	<b>\$174,042</b>

**Global Mill Liner Industry**

Copper and gold together accounted for 75% of mill liner market share during 2020, followed by iron ore and other (cement and aggregates) with 25%. The global mill liner market was estimated at \$1.73 billion in 2020. The market was oligopolistic in nature with top 5 producers capturing a global market share of 49% namely Metso-Outotec, Me Elecmetal, Bradken, PT Growth and Tega Industries.

Demand is primarily driven by Latin American countries which account for 40% of the global copper production and 8% of global gold production, largely due to the presence of large copper and iron ore mines in the region. China accounts for 10%. Tega has been servicing most of the regional mines of the major market participants as showcased in exhibit 17 and exhibit 23. The mill liner market has declined continuously in the last two years due to industry slowdown (a negative YoY growth of 3%) in 2019 and with COVID-19 (a negative 4% YoY) in the 2020. Pent-up demand is likely to ensure a rebound (at 17% YoY) in 2021 and reach \$2.03 billion.

The demand for mill liner is repeating in nature largely due to wear of mill liners. Demand of mill liners is higher in replacement against newly installed grinding machine with mill liner in a year. The ratio is expected to be about 70% to 80% from replacement and 20% - 30% are in the new installed machines. Ratio of replacement varies with amount CapEx spent in a particular year.

## Exhibit 28: Historic, Future & Current Mill Liner Demand Forecast

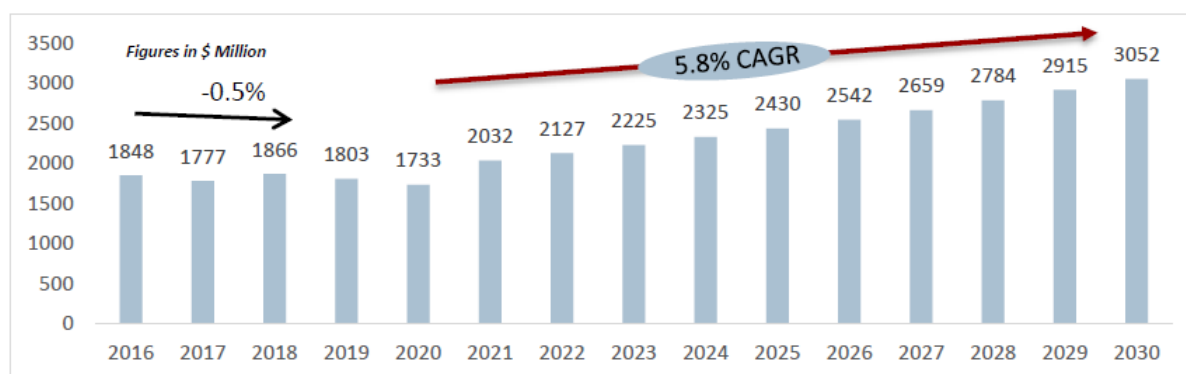

Actuals (2016–2020). Note: All figures are rounded. The base year is 2020. Source: Frost & Sullivan

Demand for copper will be driven by decarbonisation goals which will lead to more demand from the energy and automotive sector. The renewables sector will bolster copper demand through capacity additions in wind, hydro and solar power. Factors such as rising copper annual capacity in renewable energy, growing use of copper in smart home appliances, expansion of construction industry, increasing manufacturing of electrical equipment and growth in scrap copper supply would drive the growth of the industry.

However, the growth would be challenged by the decline in ore grades. Miners will have to process more ore to produce required concentrate. This will in turn boost the consumables such as mill liners growth in the mineral processing industry. Key end use sector for Gold are Jewellery, Investment, and in Industries. The advent of 'nanotechnology' is driving new uses in medicine, engineering and environmental management. Gold nanoparticles find its applications in medicines, renewable energy, engineering and aerospace as well as new technologies such as stretchable electronics.

Historically, there has been marginal growth in the copper and gold production over FY16-19 (less than 1%) which was primarily caused by general industry slowdown. Further the market was impacted due to the COVID-19 pandemic and the industry saw a de-growth in 2020. Copper and Gold together account for majority of the mill liner demand (~75% market share in 2020). Accordingly, there has been a flattish growth trend in the mill liner market in this period.

In the medium term, copper and gold production is expected to see a healthy growth, driven by increasing mining activities in the LATAM countries and growing shift towards Electric & Hybrid vehicles. Accordingly, Copper production is expected to grow at 3.7% CAGR over 2020-2030 and Gold is expected to witness a CAGR of 4.3% in the stated period.

Since mill liner demand in the past has been primarily dependent over copper and gold mining, the mill liner market growth will be a direct derivative of the same. Further, since the depleting ore grades would require higher ore beneficiation and hence higher replacement demand, the mill liner market is forecasted to grow faster at 5.8% over 2020-2030.

## Exhibit 29: Global Competition Overview, 2020

S.No	Mill Liner Manufacturer	Manufacturing Locations Country	Market Share 2020	Revenue (Mn \$) 2020	Market Share 2019	Revenue (Mn \$) 2019	Market Share 2018	Revenue (Mn \$) 2018
1.	Metso-Outotec* (Metso Outotec was formed by merger of Metso Minerals and Outotec on June 30, 2020. Revenue of Metso Outotec is captured for 2020 and comparable revenue of Metso and Outotec in 2019 as per their financial report. Financial of Metso and Outotec prior to 2019 are non relevant here)	Finland, India, Argentina, Australia, US, Peru, Brazil, Chile, Estonia, Belarus, Indonesia, Kazakhstan, Paraguay, Norway, Russia, South Africa, Sweden, UK and Uzbekistan	17%	300	16%	293	15%	-
2.	Me Elecmetal	Chile, US, China, and Zambia	13%	230	15%	265	15%	281

S.No	Mill Liner Manufacturer	Manufacturing Locations Country	Market Share 2020	Revenue (Mn \$) 2020	Market Share 2019	Revenue (Mn \$) 2019	Market Share 2018	Revenue (Mn \$) 2018
3.	Bradken	Australia, China, Canada & Malaysia	9%	163	10%	180	10%	188
4.	PT Growth	Indonesia, China, Australia, Ghana, South Africa, Chile, Peru and Mexico	5%	83	4%	79	4%	78
5.	Tega Industries	India, Chile, South Africa and Australia	5%	80	4%	68	3%	55
6.	FLSmidth	China, India and Poland	3%	54	2%	50	1%	49
7.	Uralcem	Russia	2%	31	3%	28	3%	27
8.	Weir Group	Poland, US, Mexico, Colombia, India, China, South Africa, Brazil, Peru, Chile	2%	30	2%	28	2%	28
9.	Rema Tip Top	Germany & China	2%	30	1%	27	2%	28
10.	Polycorp	Mali, Mongolia & Russia	1%	25	1%	23	1%	24
11.	Chinese Manufacturers	China	23%	400	25%	457	28%	522
12.	RoW: Others	RoW: Chile, Peru, USA, and South Africa	18%	307	17%	305	16%	300
<b>Total</b>			<b>100%</b>	<b>1,733</b>		<b>1,803</b>		<b>1,866</b>

Note: All figures are rounded. The base year is 2020. Source: Frost & Sullivan

### Exhibit 30: List of key competitors in mill liner industry

Company	Established	Headquartered	Revenue for FY 2020	EBITDA margin for FY 2020	PAT margin for FY 2020	RoE for FY 2020	RoCE for FY 2020	Industry catered
			(\$ M)					
Metso Outotec*	2020	Finland	4,042.96	11.90%	4.20%	16.50%	12.50%	Mining, Aggregates, Metal refining and Recycling
FL Smidth	1882	Denmark	2,668.74	6.90%	1.37%	2.42%	5.10%	Mining & Aggregates
Weir	1871	Scotland	2,759.60	20.00%	-7.60%	-11.34%	8.77%	Mining & Aggregates
Tega^	1976	India	116.55	27.86%	15.92%	22.23%	24.76%	Mining & Aggregates
AIA Engineering Ltd. ^	1979	India	415.47	27.10%	18.5%	14.20%	17.80%	Cement, Mining, Power, Aggregate

\*Metso Outotec was formed by merger of Metso Minerals and Outotec on June 30, 2020. Metso Oyj was incorporated on 1 July 1999 through the merger of Valmet, a paper and board machine supplier, and Rauma Oy, which focused on fiber technology, rock crushing and flow control solutions. Outotec Oyj was a Finnish listed technology company founded in 2006 offering complex mining technology and plant projects.

^Please note that the numbers mentioned for Indian companies are for the Fiscal year 2021 (2020-2021)  
Exchange rate USD 1 = INR 73.5

Out of these players, Metso-Outotec & Tega are the only two players active in polymer based mill liners. Metso Outotec is the largest polymer based mill liner supplier followed by Tega.

### Global Mill Liner Market Size by Type

The demand for metallic mill liners is highest, as they are readily available. In metallic mill liners steel mill liners are primarily alloyed, as manganese steel makes them more durable than non-alloyed steel. Steel mill liners are of better quality and available worldwide; this reduces lead time and cost. Steel mill liners are preferred in large grinding mills, unlike rubber mill liners which are best suited to small and medium-sized mills with diameter up to 6.5-meters.

Rubber abrasion mill liners are solely manufactured by rubber, its light in weight and offers quick installation. Rubber lines, often available in ball mills less than 3.8 meters in diameter, are most usually employed in smaller operations. These rubber liners are usually used in all secondary and tertiary applications in which the load in the mill is not too high. Rubber mill liners may be developed to meet most applications as a reliable standard solution. Due to its lesser weight it is more energy efficient and offers less downtime over conventional metallic mill liner.

Composite mill liners are made with a combination of the various steel alloys and rubber compounds. It is understood that steel mill liners are around 40% more heavy than these liners. There are two components lifters and plate liners that are installed from the inside of the mill using mechanical fastening. These mill liners have large demand from primary ball and SAG mill. Over the past few years mining companies have been more attracted towards composite over conventional metallic and rubber mills. The combined design of rubber and steel makes it distinctive, as it is capable of absorbing heavy impacts and preventing rolling cracks. The presence of the rubber contributes to load damping. The profile maintains for a longer period of time and increases grinding efficacy, which is a key demand of the industry, because of its increased wear resistance properties.

**Advantages of composite mill liners:**

- 1) Composite mill liners are nearly 35-40% lighter in weight compared to conventional metallic mill liners, which offers less downtime and quick installation.
- 2) Composite offers flexibility in the design and with fewer components. This reduces joints between liners and minimizes joint gaps, unlike steel liners because of the casting tolerance. The disadvantage with conventional steel mill liner is the joints can be peened as a result of impacts from the grinding balls.
- 3) Composites are faster to produce and therefore the lead times are shorter. This is a big advantage for the mining activities, during ordering the companies could be more flexible while placing demand request. It reduces the need for early ordering and the risk of milling liners being stored more than necessary on site.
- 4) Lighter mills can be optimized in order to increase volumetric capacity resulting higher production. Lighter composite facilities that allow more material to be fed into the factory without exceeding the mass limits can benefit mills with load mass limitations

Hybrid mill liner are made from a combination of the various steel alloys and the rubber compounds. The hybrid liner integrates the multiple lifter and platform components into one single unit reducing the total number of components within the mill. Hybrid liner has a special attachment system which does not require the crew to be present in the grinding mill. This makes the crew securely install the liner and the installation is faster than conventional metallic liner.

The demand for mill liners is expected to grow at a CAGR of 5.8% until 2030. In 2020, market size of composite was \$ 451 mn, rubber was \$ 312 mn and metallic liners was \$ 971 mn. Composite, Metallic and Rubber mill liners are expected to grow at CAGRs of 8.4%, 5.2%, and 3.2%, respectively. The market share of composite mill liners will increase, while the share of metallic and rubber mill liners will decrease during the forecast period. Metallic is still expected to dominate the market due to its wide availability. Composite and rubber mill liners being lighter in weight drive easy installation resulting increase in productivity over heavier metallic mill liners.

**Historic, Future & Current Mill Liner Demand Forecast**

<b>Year/CAGR Growth</b>	<b>Metallic mill liner</b>	<b>Rubber mill liner</b>	<b>Composite</b>
2020–2030	5.2 %	3.2 %	8.4 %

**Exhibit 31: Global Mill Liner Market Share Breakdown by Type, 2020 & 2030**

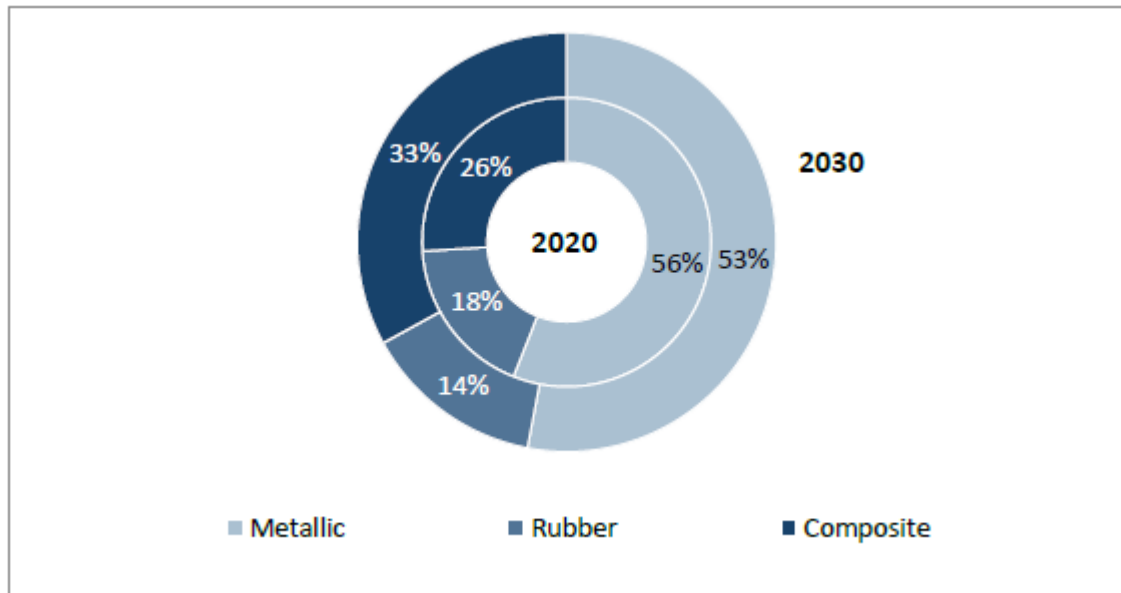

*Note: All figures are rounded. The base year is 2020. Source: Frost & Sullivan*

Metallic mill liners will continue to dominate the market until 2030. Metallic liners have higher strength but also has higher weight which demands longer grinding mill downtime. Metallic mill liners are made from steel alloys which also tend to corrode over time.

Rubber are lighter in weight and corrosion resistant, but largely preferred for small sized grinding mills. As the size of mills are increasing due to higher mining operations with depleting ores, preference towards composite has increased. Demand for rubber liners will largely be from small scale ball mills.

Demand for Composite type would increase as they have good strength and lesser weight which in turn reduces downtime for the mill and improves overall efficiency for the companies. As mill sizes are increasing the demand for lighter material with higher strength will be the key demand driving factor which would also be energy efficient.

**Global Mill Liner Market Size by Application**

SAG mills shall see high demand, as they are the most preferred for both wet and dry grinding and are critical to separating metals in mines. The cement industry is the key consumer of ball mills which are primarily used for fine grinding.

In 2020, market size of AG mills was \$ 173 mn, SAG mills was \$ 1,075 mn, Ball mills was \$ 381 mn and Others (Pebbles & Rod) was \$ 104 mn. SAG mills will dominate the market at a CAGR of 6% until 2030. AG mills, meanwhile, shall be the fastest growing mill segment at a CAGR of 6.8%. Driven by cement and aggregates, ball mills with grow at a CAGR of 5.8%. Demand for other mill types (pebble and rod mills) is set to grow marginally at a CAGR of 1.6%.

**Exhibit 30: Mill Liners operational areas based on Mill size:**

Mill Size	SAG MILL				BALL MILL			
	Rubber	Composite	Hybrid	Metallic	Rubber	Composite	Hybrid	Metallic
Dia ≤ 2.4m	SAG mill below 3.8m does not exist				Tega, Metso, Weir, Polycorp, Multotec, PT Growth, Regional Players (Ural etc.)			Less Presence
2.4 < Dia ≤ 3.8					Tega, Metso, Weir, Polycorp, Multotec, PT Growth, Regional Players (Ural etc.)			
3.8 < Dia ≤ 4.6		Tega, Metso, Weir, Polycorp, Multotec, Weir		Less Presence		Tega, Metso, Weir, Polycorp, Multotec, PT Growth, Regional Players (Ural etc.)		Medium Presence
4.6 < Dia ≤ 5.5		Tega, Metso, Weir, Polycorp, Multotec		Medium Presence		Tega, Metso, Weir, Polycorp, Multotec, PT Growth, Regional Players (Ural etc.)		
5.5 < Dia ≤ 8.5		Tega, Metso, Weir, Polycorp, Multotec					Tega, Metso, Siom	High Presence
8.5 < Dia ≤ 9.5		Tega, Metso Siom			Ball Mill above 8.5m does not exist			
9.5 < Dia ≤ 12.5			Tega	High Presence				

The Metallic liner has relatively lower presence in smaller size mill, moderate presence in mid-size mill segments, and relatively higher presence in bigger size mills.

The Metallic liner has relatively lower presence in smaller size mill, moderate presence in mid-size mill segments, and relatively higher presence in bigger size mills. Tega, Metso-Outotec and Weir closely compete with each other in composite mill liners under SAG mill category. But Tega is the only company producing hybrid mill liner for SAG mill with diameter over 9.5 to 12.5-meter range. In ball mill Tega is one among the leading global competitors in Rubber and composite mill liners and is one of top manufacturers of hybrid type mill liners in the segment range of 5.5 to 8.5 meter competing with Metso-Outotec and Siom. Tega largely focuses and has high presence in large sized mill liners with Metallic segment for both Ball and SAG mill.

SAG Mills are very popular because they can grind both dry and wet materials, and they employ crushed material inside the cylinder as the grinding medium. Autogenous mills, which separate some precious metals such as gold and silver, are popular in the main processing unit for the major industrial grinding circuits in the mining industry. Ball mills are fine grinders that come in both horizontal and vertical mills, with cylinders partially filled with steel, manganese, or ceramic balls.

Year/CAGR Growth	AG Mill liner	SAG Mill liner	Ball Mill liner	Others (Pebbles and Rod mill)
2020-2030	6.8 %	6.0 %	5.8 %	1.6 %

**Exhibit 32: Global Mill Liner Market Share Breakdown by Type of Mill, 2020 & 2030**

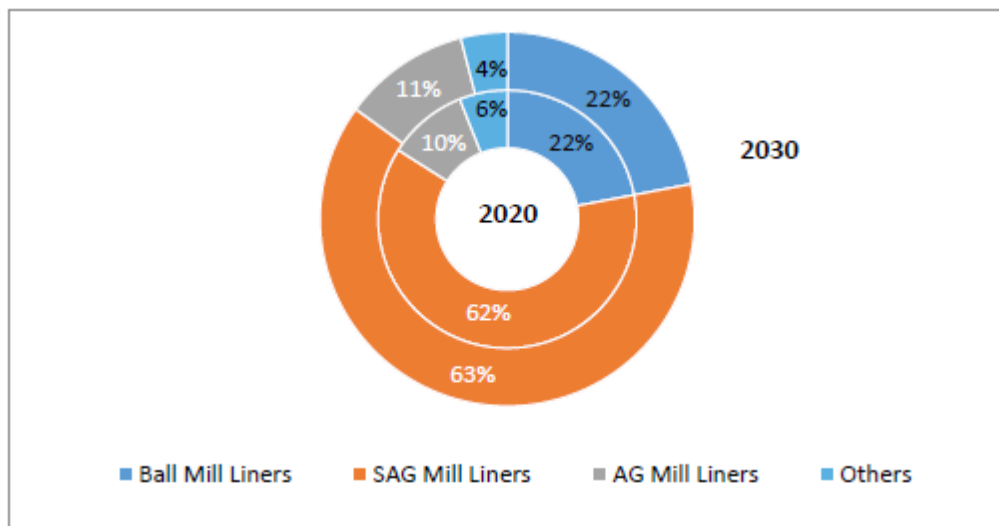

Note: All figures are rounded. The base year is 2020. Source: Frost & Sullivan.

### Global Mill Liner Market Size by Industry

Gold is currently the largest consumer of mills. The demand in copper mines will eventually increase with exhausting copper concentrates. In 2020, mill liner market in Gold was \$ 728 mn, copper was \$ 572 mn, Iron ore was \$ 208 mn and others (cement & aggregates) was \$ 225 mn. Mill liner demand in gold mining is expected to grow at a CAGR of 6.1% by 2030, while the demand for copper mines will grow at a CAGR of 6.4%. Mill liner demand in the iron ore industry is expected to grow at a CAGR of 6.7% due to the growing demand for ore beneficiation. The demand for mill liners in other segments, such as cement and aggregates, is expected to grow at a CAGR of 2% until 2030.

### Historic, Future & Current Mill Liner Demand Forecast by Industry

Year/CAGR Growth	Gold	Copper	Iron Ore	Others (Cement & Aggregates )
2020–2030	6.1 %	6.4 %	6.7 %	2.0 %

Note: All figures are rounded. The base year is 2020. Source: Frost & Sullivan

Mill liner applications in the gold and copper industry will be the top driver. The global demand for copper in EVs and electronics will grow. Aluminum cannot replace copper in certain conductor applications, as copper has better ductility, also copper is more durable than aluminum which could be easily molded, malleability, and durability. Likewise, gold production is expected to grow, as Russia is planning to increase its mining operations and is poised to overtake China to become the largest producer of gold. The steady growth of low-grade iron ore beneficiation, particularly in China and Brazil, will also drive up the demand for mill liners.

Low grade iron ore beneficiation has grown at a good pace in recent years; countries like China and Brazil are prominent in the industry.

### Exhibit 33: Global Mill Liner Market Share Breakdown by Industry, 2020 & 2030

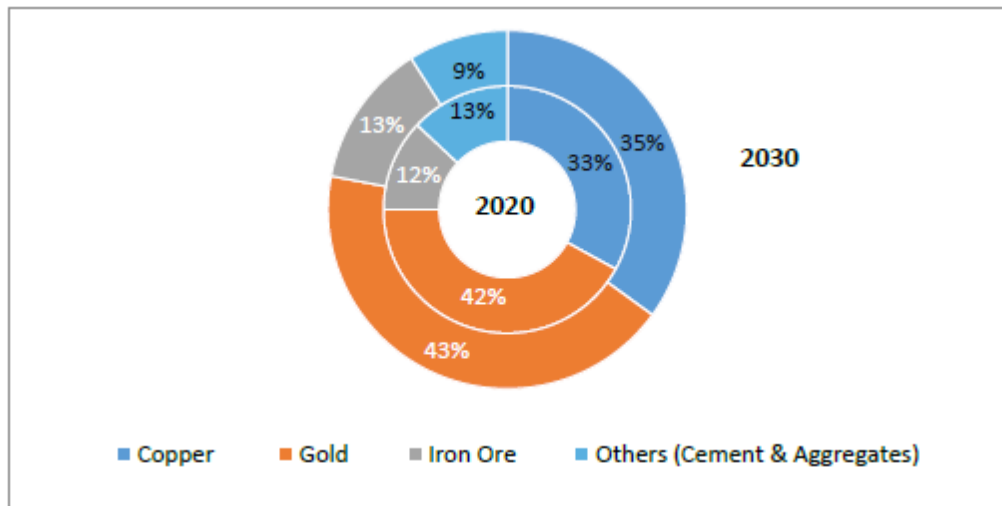

Note: All figures are rounded. The base year is 2020. Source: Frost & Sullivan



**Exhibit 34: Historic, Future & Current Mill Liner Demand Forecast by Region**

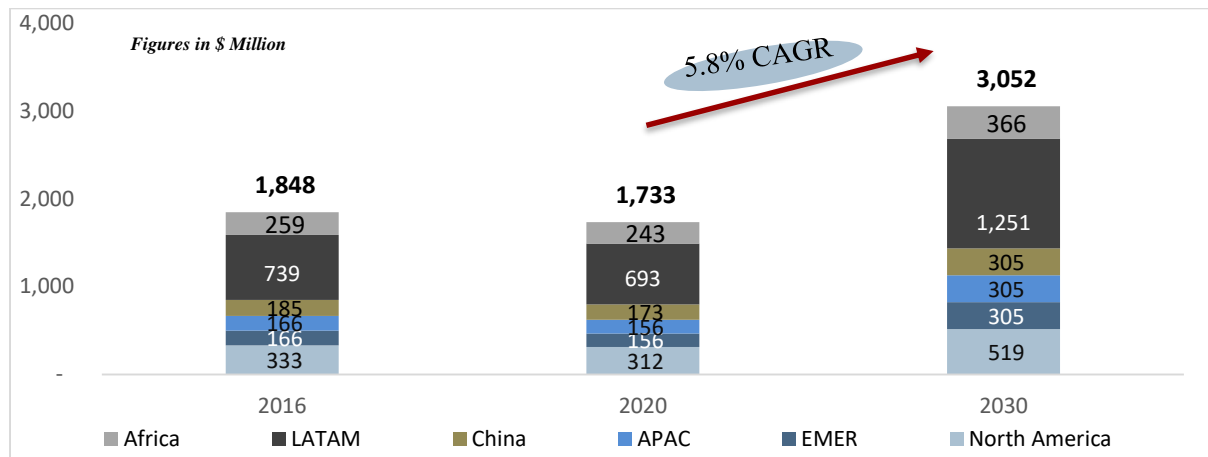

Actuals (2016 & 2020)

Region	Year/CAGR Growth (2020–2030)
North America	5.2 %
EMER	6.9 %
APAC	6.9 %
LATAM	6.1 %
Africa	4.2 %
China	5.8 %
<b>Global</b>	<b>5.8 %</b>

Note: All figures are rounded. The base year is 2020. Source: Frost & Sullivan

**Exhibit 35: Global Mill Liner Market Share Breakdown by Region, 2020 & 2030**

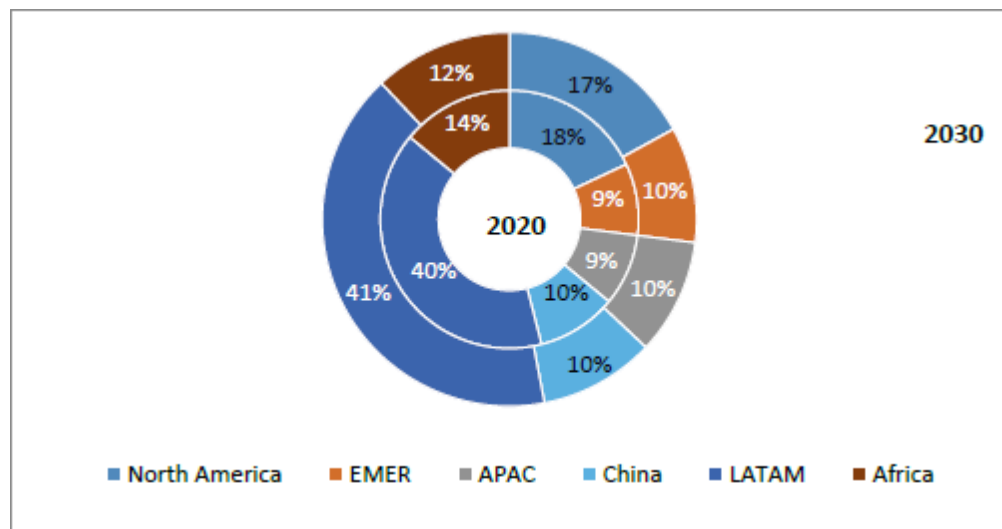

Note: All figures are rounded. The base year is 2020. Source: Frost & Sullivan

LATAM will continue to dominate the mill liner market, as it will remain the largest producer of both gold and copper. EMER demand share is expected to grow as Russia becomes the largest producer of gold. China's share will remain unchanged, as it will see higher beneficiation of low-grade iron ore over the next few years. Demand from North America is expected to decline marginally, as gold production is likely to reduce. Australia's production of both copper and gold will raise the demand for mill liners in APAC.

## REVIEW AND OUTLOOK OF THE GLOBAL HYDROCYCLONE INDUSTRY

### Overview

A hydrocyclone has no moving part but generates centrifugal force using fluid pressure and a flux pattern that can separate particulate matter and droplets from a fluid medium. To achieve separation, such particles or droplets

must have an appropriate density, relative to the medium. The flow is cyclonic inside the hydrocyclone. These machines are primarily used for desliming and dewatering of minerals and construction materials.

**Exhibit 36: Hydrocyclone**



Source: Tega Industries

Gold, copper, iron ore, coal and construction industry are the leading end users of hydrocyclones.

**Exhibit 37: Hydrocyclone Industry Value Chain**

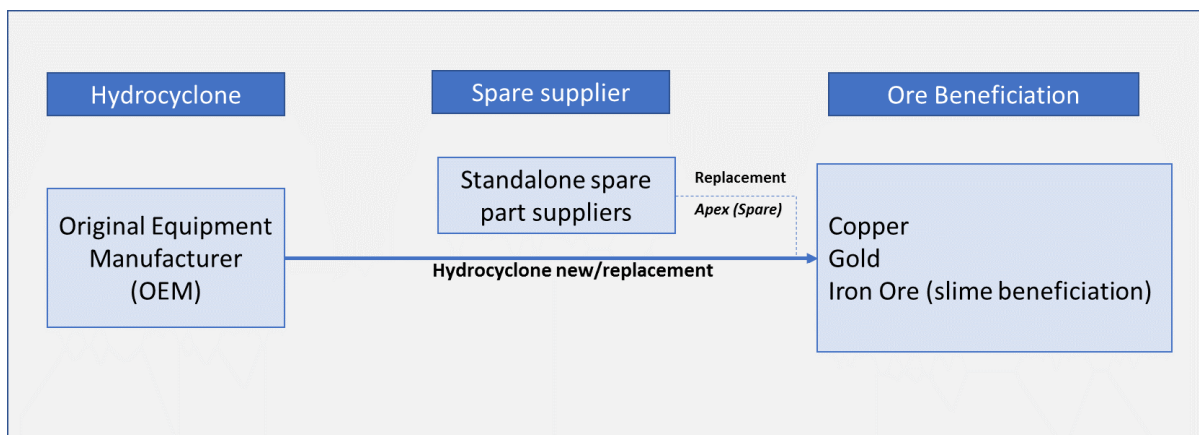

Source: Frost & Sullivan

**Global Hydrocyclone Market Size**

Gold, copper, and iron ore segments account for 60% of the demand for hydrocyclones. Coal and construction are the other key segments.

The global hydrocyclone market was estimated to be \$671 million in 2020. Weir, FL Smidth, Metso, Schlumberger and Technip are the top 5 suppliers, accounting for 43.1% of the market share.

Owing to copper and iron ore mining activities, LATAM countries account for 35% of the global demand for hydrocyclones.

### Exhibit 38: Historic, Future & Current Hydrocyclone Demand Forecast

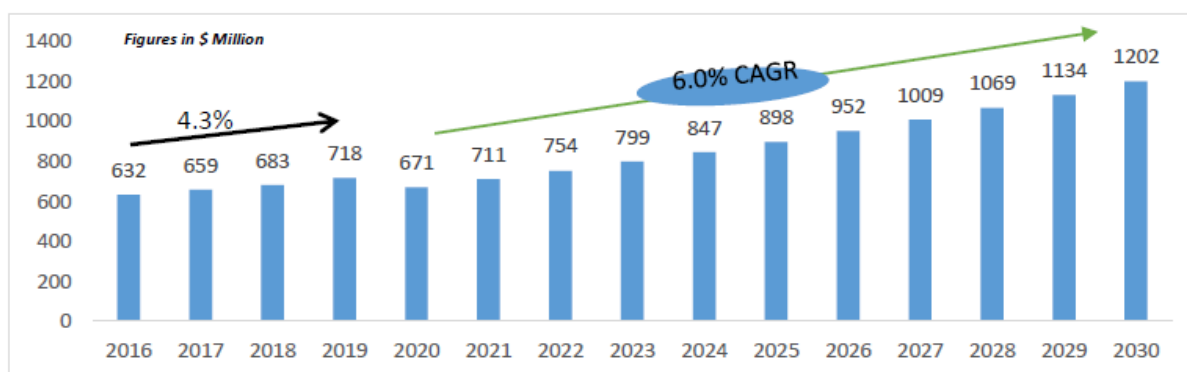

Actuals (2016–2020); Note: All figures are rounded. The base year is 2020. Source: Frost & Sullivan

The global hydrocyclone market is expected to grow at a CAGR (2020–2030) of 6.0% to reach \$1.2 billion by 2030.

Demand for hydrocyclones will resume gradually with the rebound in automotive, construction, and consumer durables segments.

### Exhibit 39: Global Competition Overview: 2020

No.	Hydrocyclone Manufacturer	Market Share (%)	2020 Revenue (\$ M)
1	Weir Group	12.20%	82
2	FL Smith	9.70%	65
3	Metso Corp.	6.70%	45
4	Schlumberger	6.00%	40
5	Technip FMC	5.40%	36
6	KSB	3.40%	23
7	Siemens	3.30%	22
8	Exterran	1.60%	11
9	Multotec	1.6%	11
10	Weihai Haiwang	1.3%	9
11	ROW: Others	50.06%	327
<b>Total</b>		<b>100%</b>	<b>671</b>

Note: All figures are rounded. The base year is 2020. Source: Frost & Sullivan

### Global Hydrocyclone Market Size by Type

The demand for solid-liquid hydrocyclone is dominant as it is used in metals and construction. Copper and gold are among the key demand contributors to this segment. Liquid-liquid hydrocyclone are used (in the crude oil industry) to separate oil from water by the cyclonic effect. Demand for dense media cyclone is primarily driven by the coal industry.

**Exhibit 40: Historic, Future & Current Hydrocyclone Demand Forecast**

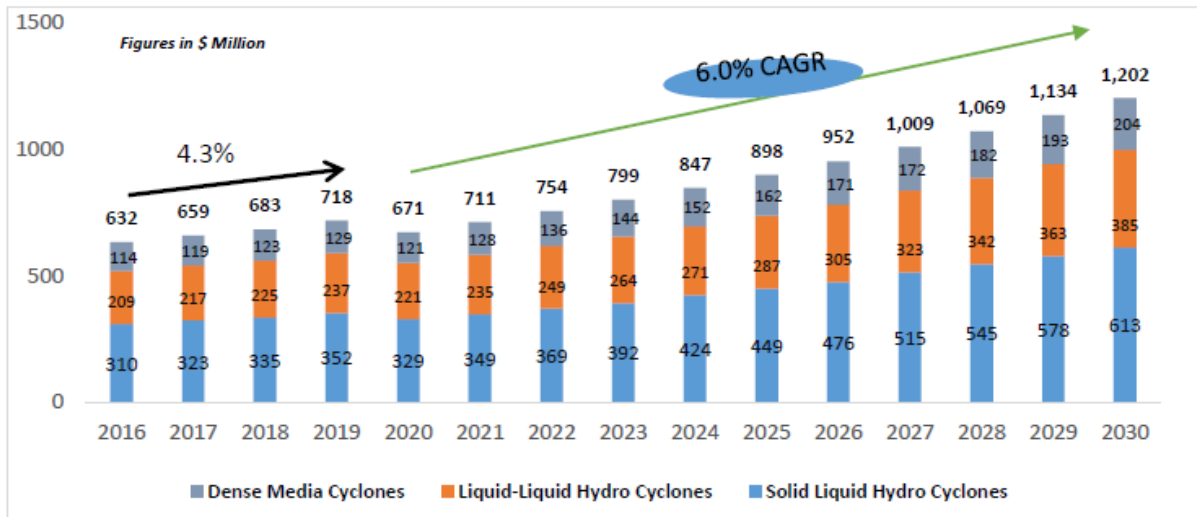

Actuals (2016–2020)

Year/CAGR Growth	Solid Liquid Hydrocyclone	Liquid-Liquid Hydrocyclone	Dense Media Cyclone
2020–2030	6.4 %	5.7 %	5.4 %

Note: All figures are rounded. The base year is 2020. Source: Frost & Sullivan.

**Global Hydrocyclone Market Size by Industry Sector**

Hydrocyclones are primarily used in mineral slurry separation. As copper and gold ore concentration depletes, miners will have to excavate more for optimal yield.

The demand for hydrocyclones in the copper industry is expected to grow at a CAGR of 7.6%. Similarly, the demand for hydrocyclone in the gold industry will grow at a CAGR of 7.0% due to the higher number of excavation and exploration projects already underway across the world. Beneficiation of iron ore is gaining popularity; China and Brazil are the top countries where demand is expected to grow at a CAGR of 5.3%. The focus on clean and sustainable fuel could dampen the demand for hydrocyclones in the oil and coal industries.

**Exhibit 41: Historic, Future & Current Hydrocyclone Demand Forecast by Industry**

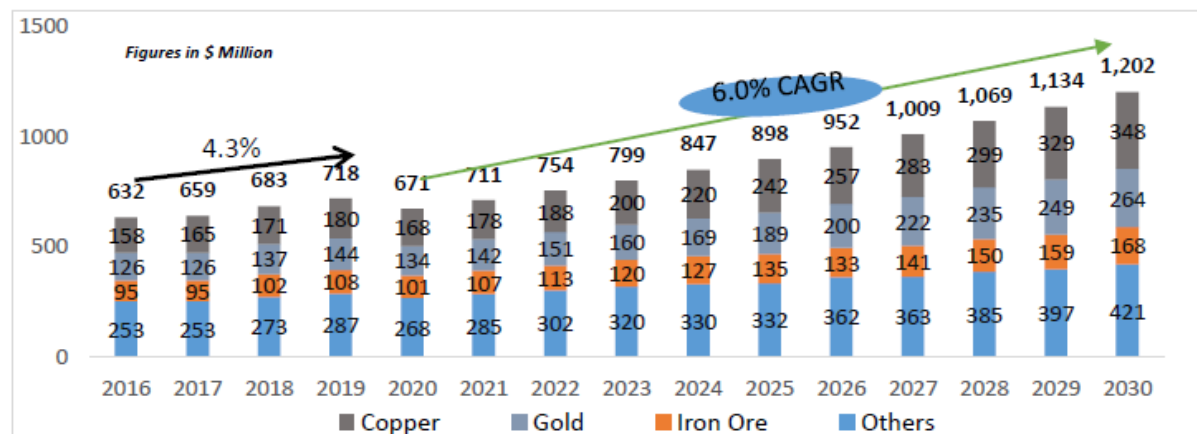

Actuals (2016–2020)

Year/CAGR Growth	Gold	Copper	Iron Ore	Others (Coal, Crude, Construction and so on)
2020–2030	7.6 %	7.0 %	5.3 %	4.6 %

Note: All figures are rounded. The base year is 2020. Source: Frost & Sullivan.

**Exhibit 42: Global Hydrocyclone Market Share Breakdown by Industry, 2020 & 2030**

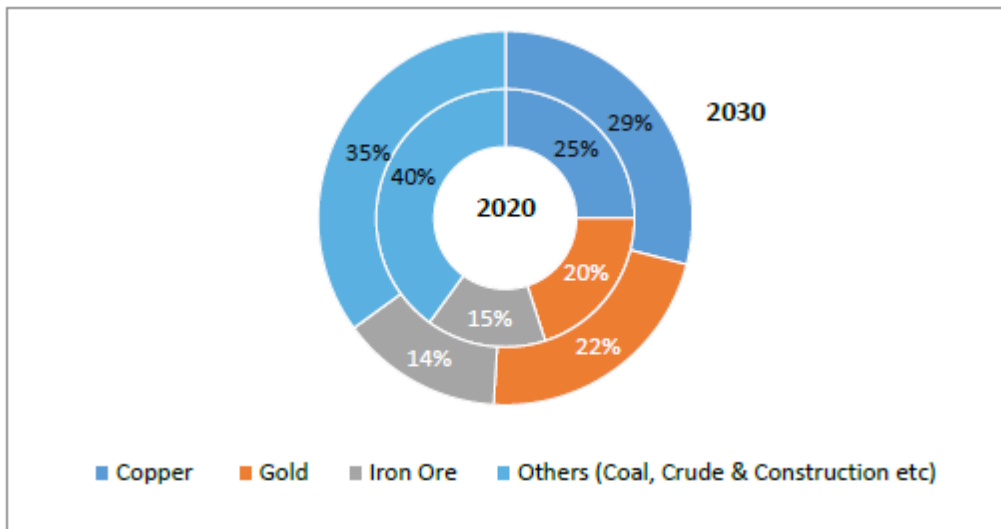

Note: All figures are rounded. The base year is 2020. Source: Frost & Sullivan.

**Exhibit 43: Historic, Future & Current Hydrocyclone Demand Forecast by Region**

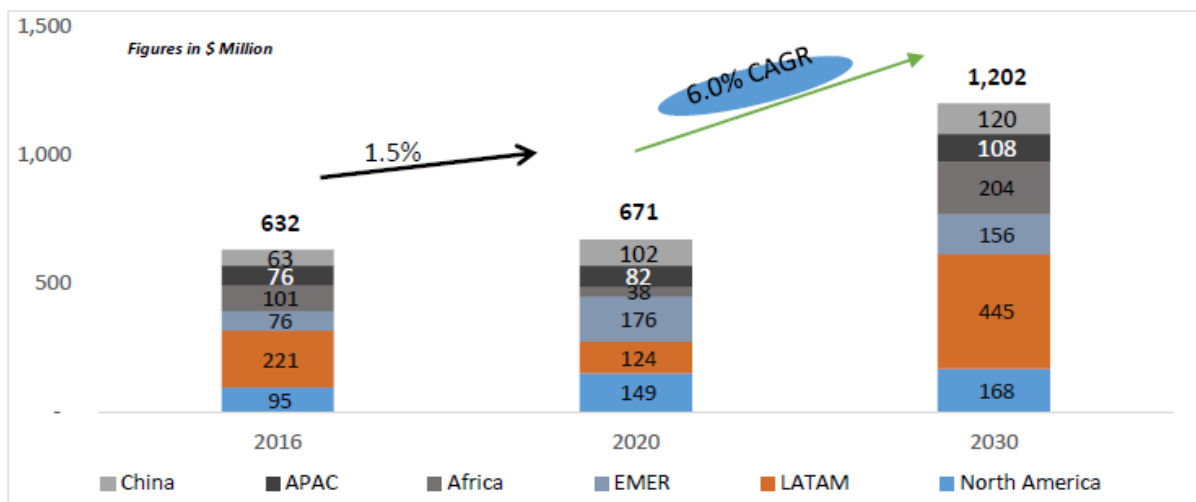

Actuals (2016 & 2020)

Region	Year/CAGR Growth (2020–2030)
North America	5.3 %
EMER	6.9 %
APAC	3.0 %
LATAM	6.6 %
Africa	7.0 %
China	6.0 %
<b>Global</b>	<b>6.0 %</b>

Note: All figures are rounded. The base year is 2020. Source: Frost & Sullivan

**Exhibit 44: Global Hydrocyclone Market Share Breakdown by Region, 2020 & 2030**

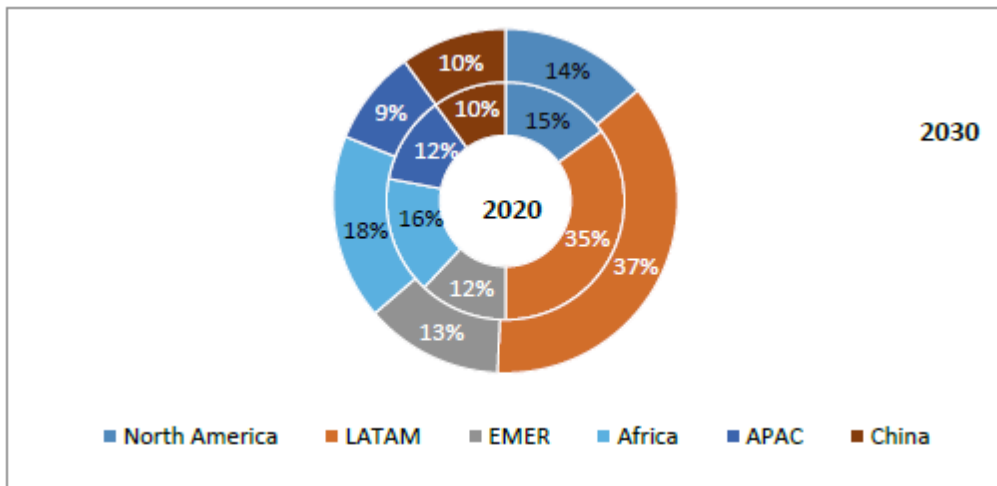

Source: Frost & Sullivan

**REVIEW AND OUTLOOK OF THE GLOBAL TROMMEL AND SCREEN MEDIA INDUSTRY**

**Overview**

A trommel screen or a rotary screen is a mechanical screening machine that separates materials and finds application in mining, fertilizer, compost, aggregates, and so on. A trommel consists of a cylindrical machine fitted with curved screens, which screen and sort crushed ore by particle size. Trommel screen is divided into several sections, based on the requirement, and the mesh holes for each section are different.

**Exhibit 45: Trommel Screen**

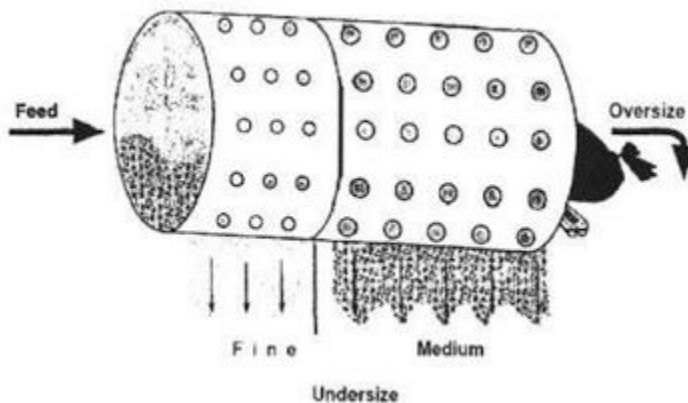

Source: Perrymining

The global trommel screen market was estimated to be \$0.94 billion in 2020. Multotec, Sandvik, FL Smidth, and Metso are the top companies, and they command about 85% of the global market share. Demand is primarily driven by copper and iron mines in Latin American countries which account for 35% of the global trommel screen revenue. China accounts for 10% of the global demand for trommel screens.

### Exhibit 46: Trommel Screen Industry Value Chain

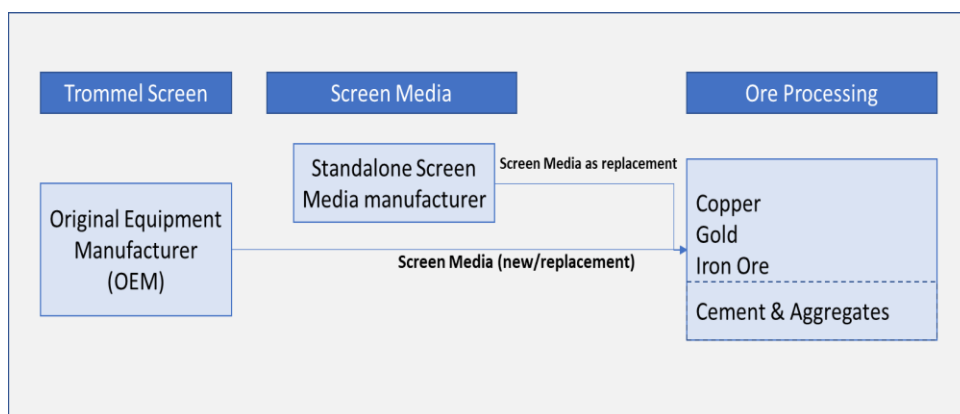

Source: Frost & Sullivan

### Global Trommel Screen industry

Iron mines accounted for 44% of the total demand/revenue for trommel screens due to the sheer volume of iron ore processing in 2020. Copper and gold are the top end-user industries, accounting for about 27% of the total trommel screen market in 2020. The global trommel screen market was estimated at \$942 million in 2020. The trommel screen industry is highly fragmented, as there are many regional fabricators that cater to local demand. FL Smidth, Metso, Sandvik are the some of the top companies; they command about 50% global market share.

### Exhibit 47: Historic, Future & Current Trommel Demand Forecast

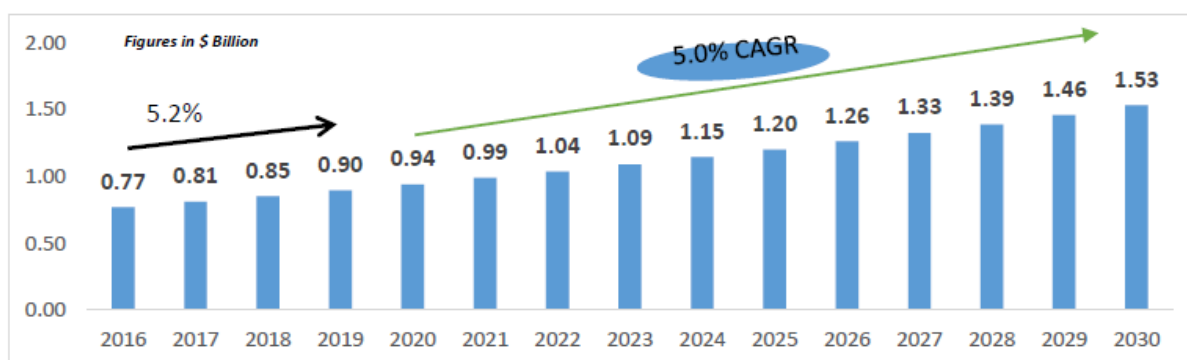

Actuals (2016–2020). Note: All figures are rounded. The base year is 2020. Source: Frost & Sullivan

### Exhibit 48: Global Competition Overview, 2020

S.No	Mill Liner Manufacturer	Manufacturing Locations Country	Market Share 2020	Revenue (Mn \$) 2020	Market Share 2019	Revenue (Mn \$) 2019	Market Share 2018	Revenue (Mn \$) 2018
1.	Metso-Outotec*	Finland, India, Argentina, Australia, US, Peru, Brazil, Chile, Estonia, Belarus, Indonesia, Kazakhstan, Paraguay, Norway, Russia, South Africa, Sweden, UK and Uzbekistan	17%	300	16%	293	15%	-
2.	Me Elecmetal	Chile, US, China, and Zambia	13%	230	15%	265	15%	281
3.	Bradken	Australia, China, Canada & Malaysia	9%	163	10%	180	10%	188
4.	PT Growth	Indonesia, China, Australia, Ghana, South Africa, Chile, Peru and Mexico	5%	83	4%	79	4%	78

S.No	Mill Liner Manufacturer	Manufacturing Locations Country	Market Share 2020	Revenue (Mn \$) 2020	Market Share 2019	Revenue (Mn \$) 2019	Market Share 2018	Revenue (Mn \$) 2018
5.	Tega Industries	India, Chile, South Africa and Australia	5%	80	4%	68	3%	55
6.	FLSmidth	China, India and Poland	3%	54	2%	50	1%	49
7.	Uralcem	Russia	2%	31	3%	28	3%	27
8.	Weir Group	Poland, US, Mexico, Colombia, India, China, South Africa, Brazil, Peru, Chile	2%	30	2%	28	2%	28
9.	Rema Tip Top	Germany & China	2%	30	1%	27	2%	28
10.	Polycorp	Mali, Mongolia & Russia	1%	25	1%	23	1%	24
11.	Chinese Manufacturers	China	23%	400	25%	457	28%	522
12.	RoW: Others	RoW: Chile, Peru, USA, and South Africa	18%	307	17%	305	16%	300
<b>Total</b>			<b>100%</b>	<b>1,733</b>		<b>1,803</b>		<b>1,866</b>

Note: All figures are rounded. The base year is 2020. Source: Frost & Sullivan.

Based on the requirement of the mine operator, a trommel screen can be either static or mobile. Mobile trommel has advantage of flexibility of movement where the operation does not require the Trommel to be fixed at one place and the miner can use the same trommel screen at different locations. In large mines where the beneficiation is done at the plants stationary Trommels are preferred. About 34% of the total Trommel market is Stationary Trommels. Tracked Trommels constitute about 26% of the total market and 17% is Wheeled Trommels. Mobile trommels offer flexibility, and a miner can use the same trommel screen at different locations. Conversely, larger mines use stationary trommels to complete the ore beneficiation process in the plant. Stationary trommels account for 34% of the market; tracked trommels, 26%; and wheeled trommels, 17%

#### Exhibit 49: Historic, Future & Current Trommel Demand Forecast

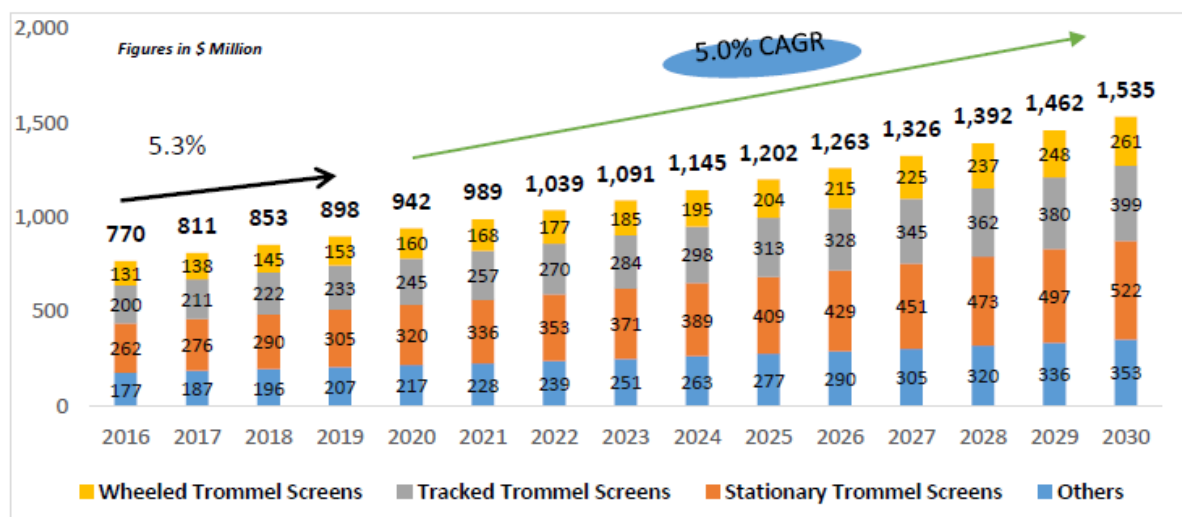

Actuals (2016–2020). Note: All figures are rounded. The base year is 2020. Source: Frost & Sullivan.



**Exhibit 50: Historic, Future & Current Trommel Screen Demand Forecast by Industry**

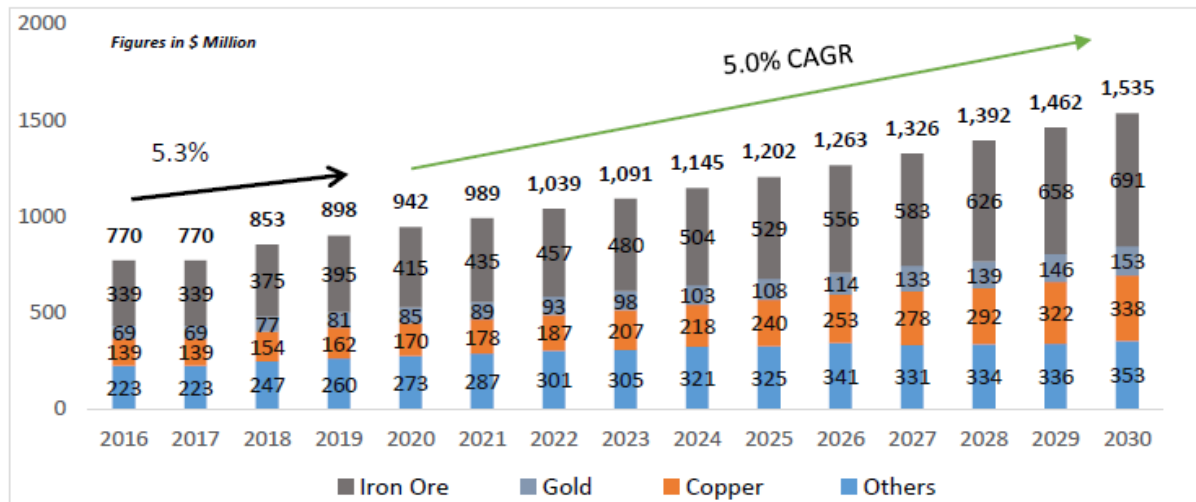

Actuals (2016-2020)

Year/CAGR Growth	Gold	Copper	Iron Ore	Others (Cement & Aggregates)
2020-2030	7.1 %	6.1 %	5.2 %	2.6 %

Note: All figures are rounded. The base year is 2020 Source: Frost & Sullivan

Gold and copper will be the top end-user industries of screen trommel, as its application in the ore beneficiation process will increase, particularly in Latin American, Africa, Australia, China, Russia and North America.

**Exhibit 51: Global Trommel Market Share Breakdown by Industry, 2020 & 2030**

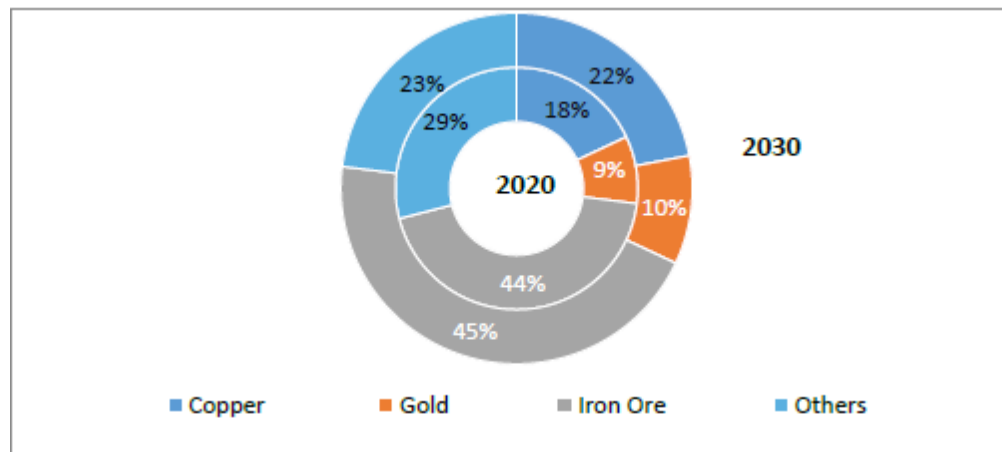

Note: All figures are rounded. The base year is 2020. Source: Frost & Sullivan

The demand for screen trommel from iron ore (2400 million tons) applications is expected to grow 45% by 2030. The demand from copper and gold (now 27%) will grow to 32% because of higher mining volumes and depleting ore grades. Waste incineration is also another top screening applications.

**Global Trommel Screen Demand by Region**

Latin America (LATAM) is the largest producer of copper globally and simultaneously it contributes to 35% demand of mill liners. Chile and Peru are the key contributors in region for copper and Brazil is the key producer of iron ore and its beneficiation globally.

China is the largest consumer of mill liners as it is the largest producer of Gold and 3<sup>rd</sup> largest producer of copper globally; mill liner market is fairly dominated by domestic players.

**Exhibit 52: Historic, Future & Current Trommel Screen Demand Forecast by Region**

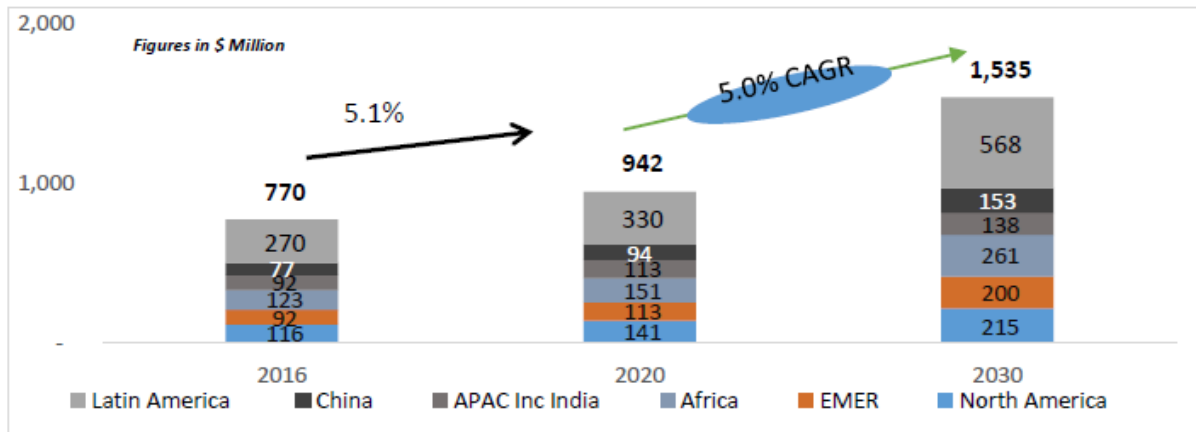

Actuals (2016 & 2020)

Region	Year/CAGR Growth (2020–2030)
North America	4.3 %
EMER	5.8 %
APAC	2.0 %
LATAM	5.6 %
Africa	5.6 %
China	5.0 %
<b>Global</b>	<b>5.0 %</b>

Note: All figures are rounded. The base year is 2020. Source: Frost & Sullivan

**Exhibit 53: Global Trommel Market Share Breakdown by Region, 2020 & 2030**

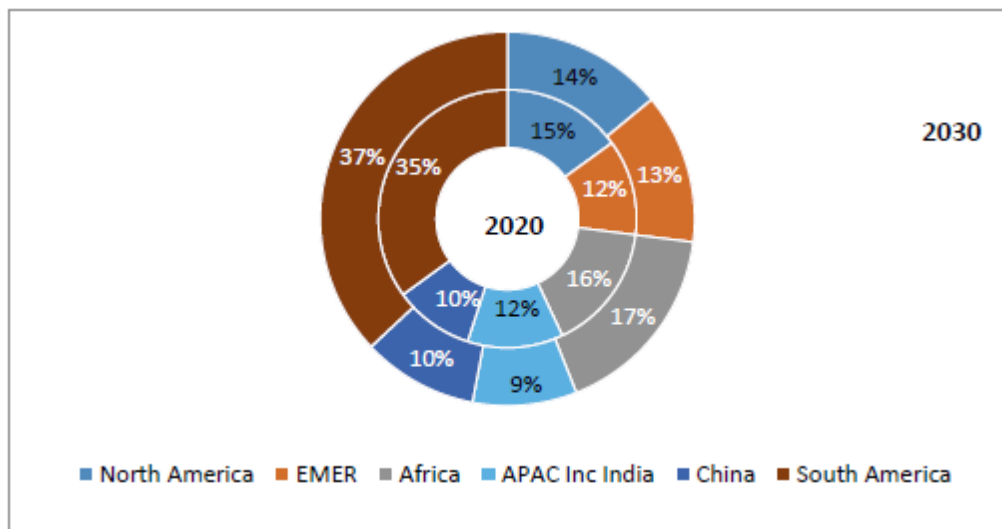

Note: All figures are rounded. The base year is 2020. Source: Frost & Sullivan

South America will continue to dominate the trommel screen market, as it will remain the largest producer of both gold and copper. EMER demand share is expected to grow, as Russia will become the largest producer of gold. China's share will remain unchanged, as it tries to increase the beneficiation of low-grade iron ore over the next few years. Demand from North America is expected decline marginally, as gold production is expected to reduce. Australia is expected to increase the production of both copper and gold, which would raise the demand for trommel screen in APAC.

**Exhibit 54: Operational Parameters (Industry Catered to, Sales & Distribution Reach, Development Plans in the Next Few Years)**

Company	Industry Catered	Sales & Distribution Reach	Development Plans & Key Product Offerings
<b>Metso-Outotec</b>	Mining, Aggregates, Metal refining and Recycling	Finland, India, Argentina, Australia, US, Peru, Brazil, Chile, Estonia, Belarus, Indonesia, Kazakhstan, Paraguay, Norway, Russia, South Africa, Sweden, UK and Uzbekistan	<p><b>Mill Liners:</b> Skega Poly-Met™ is a hybrid mill liner which is a combination of rubber and steel. Megaliner™ is primarily developed for large AG, SAG, and ball mills to reduce downtime. Orebed™ is a designed for magnetic type ores. The company also supplies rubber and metal mill liners.</p> <p><b>Hydrocyclone:</b> MHC™ is trademarked, and the company has filed for patent. The inlet head, which allows smoother flow of material into the hydrocyclone, was designed in house by CFD-DEM software.</p> <p><b>Trommel:</b> The company manufactures trommel primarily for aggregates and the mining industries. Portable and ultrafine trommels are primarily designed for the mining industry.</p>
<b>FL Smith</b>	Mining & Aggregates	China, India, and Poland	<p><b>Mill Liners:</b> The company promotes PulpMax™, a lightweight composite mill liner for better life and also manufactures metal and rubber liners.</p> <p><b>Hydrocyclone:</b> The company has introduced SmartCyclone™ to monitor and control the grinding process, to reduce cyclone-related process upsets, and to improve cyclone overflow particle size distribution.</p> <p><b>Trommel:</b> The frames are designed and manufactured in house by finite element analysis (FEA), which calculates static and fatigue/strength assessment.</p>
<b>Weir</b>	Mining & Aggregates	Poland, US, Mexico, Colombia, India, China, South Africa, Brazil, Peru, Chile	<p><b>Mill Liner:</b> Weir promotes hybrid, rubber and composite mill liners for better wear resistance under the brand Vulco® and also supplies metal mill liners.</p> <p>Weir's <b>Hydrocyclone</b> is registered as Cavex®; the company has also registered a laminar spiral inlet design which offers natural flow path in the hydrocyclone.</p> <p>Weir's <b>Screen Media</b> is registered under the brand Linatex®; the screen media are used in mineral processing, construction, and aggregates industries.</p>

Source: Frost & Sullivan, Industry sources

## BUSINESS

*Some of the information in the following discussion, including information with respect to our plans and strategies, contain forward-looking statements that involve risks and uncertainties. You should read the section “**Forward-Looking Statements**” on page 16 for a discussion of the risks and uncertainties related to those statements. Our actual results may differ materially from those expressed in or implied by these forward-looking statements. Also read “**Risk Factors**” and “**Management’s Discussion and Analysis of Financial Condition and Results of Operations – Significant Factors Affecting our Results of Operations**” on pages 23 and 320, respectively, for a discussion of certain factors that may affect our business, financial condition or results of operations.*

*Unless otherwise indicated or the context otherwise requires, the financial information for the three months period ended June 30, 2021 and Fiscals 2021, 2020 and 2019, included herein is derived from the Restated Consolidated Financial Information, included in this Red Herring Prospectus. For further information, see “**Financial Information**” on page 207.*

*Our Company’s Fiscal commences on April 1 and ends on March 31 of the immediately subsequent calendar year, and references to a particular Fiscal are to the 12 months ended March 31 of that particular year. Unless otherwise indicated or the context otherwise requires, in this section, references to “the Company” or “our Company” are to Tega Industries Limited on a standalone basis, and references to “the Group”, “we”, “us”, “our”, are to Tega Industries Limited its subsidiaries and the joint venture on a consolidated basis.*

*Unless otherwise indicated, industry and market data used in this section have been derived from the report “**Global Market Assessment – Select Mineral Processing Equipment**” dated October 12, 2021 (the “**F&S Report**”) prepared and released by F&S and commissioned and paid for by our Company in connection with the Offer. Unless otherwise indicated, all financial, operational, industry and other related information derived from the F&S Report and included herein with respect to any particular year refers to such information for the relevant calendar year. Also see, “**Certain Conventions, Use of Financial Information and Market Data and Currency of Presentation – Industry and Market Data**” on page 13.*

*In this section, the following terms shall have the meanings set out herein:*

*“beneficiation” refers to the process of improvement of the economic value of ore by removing waste and byproducts to achieve a higher grade ore concentrate.*

*“tribology” refers to the science and engineering of interacting surfaces in relative motion.*

### Overview

We are a leading manufacturer and distributor of specialized ‘critical to operate’ and recurring consumable products for the global mineral beneficiation, mining and bulk solids handling industry, on the basis of sales as of June 30, 2021 (*Source: F&S Report*). Globally, we are the second largest producers of polymer-based mill liners, on the basis of revenues as of June 30, 2021 (*Source: F&S Report*).

We offer comprehensive solutions to marquee global clients in the mineral beneficiation, mining and bulk solids handling industry, through our wide product portfolio of specialized abrasion and wear-resistant rubber, polyurethane, steel and ceramic based lining components, used by our customers across different stages of mining and mineral processing, screening, grinding and material handling, including after-market spends on wear, spare parts, grinding media and power, which are regular operating expenses for our customers. Our engineering capability, which has evolved over decades, has enabled us to consistently offer our quality, complex manufactured products within stipulated timelines, allowing us to reduce downtime and maximize operational efficiency for our customers, and forge robust relationships with our customers leading to high recurring revenues.

We commenced operations in 1978 in India, with a foreign collobaration with Skega AB, Sweden. Madan Mohan Mohanka acquired the entire equity stake of Skega AB in our Company in 2001. Our individual Promoters are Madan Mohan Mohanka, Manju Mohanka, Manish Mohanka and Mehul Mohanka. Our MD and CEO, Mehul Mohanka, has been involved in the Company’s business for the last 18 years, and has led our business as our Managing Director and Group CEO for the last 5 years. In 2011, we received funding from Wagner Ltd., an entity affiliated with TA Associates, a global private equity firm.

Our product portfolio comprises more than 55 mineral processing and material handling products. As an average of the last three Fiscals i.e., 2021, 2020 and 2019, sale of products constitutes 95.08% of our revenue from

operations, while our sale of services and other operating revenue constitutes 2.15% and 2.77%, respectively of our revenue from operations. For the three months period ended June 30, 2021, the sale of products constitutes 94.56% of our revenue from operations, while the sale of services and other operating revenue constitutes 3.33% and 2.11%, respectively of our revenue from operations.

Our mineral processing and material handling products offering covers a wide range of solutions in the mining equipment, aggregates equipment and the mineral consumables industry.

Our products offering include consumables required in the mines and mineral processing industry. In the sequence of their usage in the mineral processing value chain, after blasting to floatation, our products include chutes and its liners, grinding mill liners, trommels and screens, hydrocyclones, pumps and flotation parts and conveyor products. Our product range is engineered with a combination of mineral processing engineering, mechanical engineering and material sciences, while utilising our expertise in tribology.

Below is a diagrammatic representation our product range used in the mineral processing and material handling industry value chain:

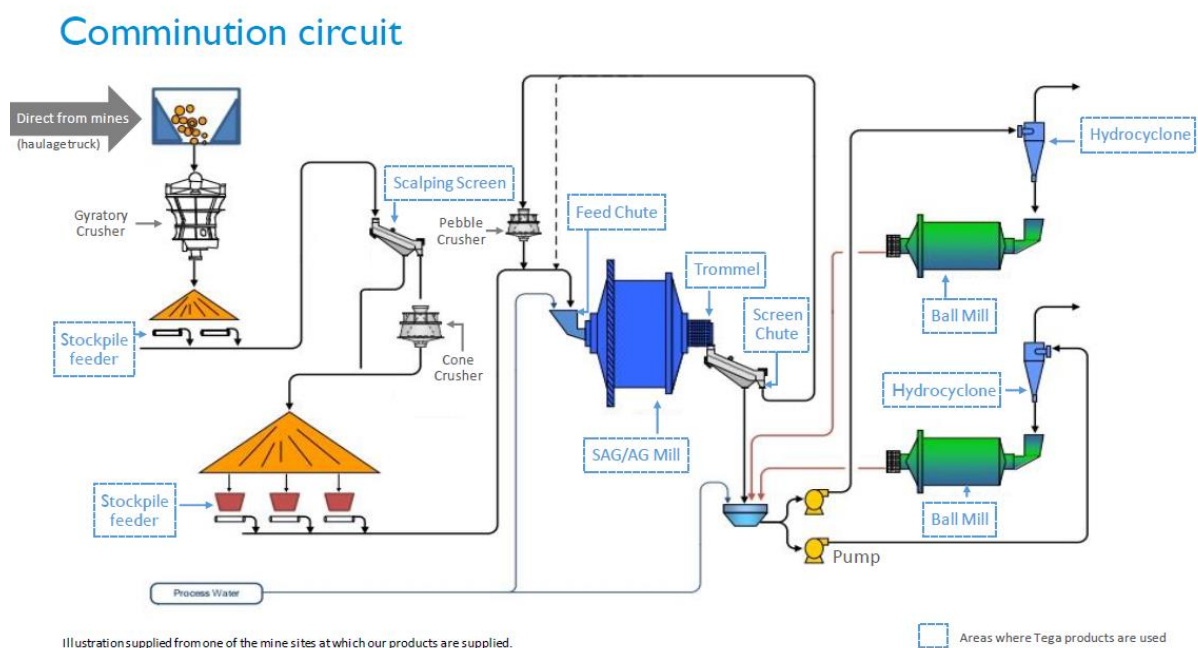

Revenue from operation from outside India constituted 84.48%, 86.42%, 85.92% and 85.83% of our revenue from operations in the three months period ended June 30, 2021 and Fiscals 2021, 2020 and 2019, respectively. For details of the revenue and profit/(loss) contribution of our Subsidiaries in the last three Fiscals, see '**Risk Factors- Our global manufacturing facilities, sales and operations expose us to the risks of doing business in foreign countries, which may adversely affect our business, financial condition and results of operations**' and '**Restated Consolidated Financial Information- Annexure V - Notes to the Restated Consolidated Financial Information- Note 50**' on pages 23 and 300. Further, for details of our production capacity and actual production in the last three Fiscals, see '**-Manufacturing Facilities**' on page 157. For the last three Fiscals, we have presence in 513, 498 and 479 installation sites, respectively, in over 70 countries. Further, for the three months period ended June 30, 2021, we have presence in 212 installation sites. Revenue from operation from outside India include North America, South America, EMER (Europe, Middle East and Russia), Africa, and Asia Pacific (South East Asia and Australia) which constituted 17.66%, 19.23%, 14.18%, 21.18% and 12.23% of our revenue from operations for the three months period ended June 30, 2021 and 13.74%, 24.71%, 15.49%, 22.62% and 9.85% of our revenue from operations in Fiscal 2021. We are further expanding our operations in major markets including North America, South America, Australia (part of Asia Pacific) and South Africa. Our focus end-customers are mineral processing sites involved in gold and copper ore beneficiation, accounting for 34.92% and 27.25% respectively of our sale of products as an average of the last three Fiscals and 45.48% and 20.76% respectively of our sale of products for the three months period ended June 30, 2021.

We have six manufacturing sites, including three in India, at Dahej in Gujarat and at Samali and Kalyani in West Bengal, and three sites in major mining hubs of Chile, South Africa and Australia, with a total built-up area of

74,255 Sq. mts. Our facilities in India caters to the domestic and overseas markets across mineral processing and materials handling industries, while our facilities in Chile, South Africa and Australia caters to their respective local and regional mineral processing and materials handling industries. Additionally, our joint venture in India with U.K. branch of Hosch Group, Germany is engaged in precision conveyer belt cleaning and caters to various industries in India. We also have 18 global and 14 domestic sales offices located close to our key customers and mining sites.

With on-ground presence in all major mining locations, we are well positioned to cater to our customers across the world which comprise large global mining companies as well as small and medium size companies in the mining and mineral beneficiation industry in developed countries as well as in emerging regions.

In order to expand our operations globally, we acquired Tega Industries Africa (Pty) Ltd. (formerly, Beruc Equipment (Proprietary) Limited) (“**Tega Africa**”) in FY 2007 which is a South Africa based manufacturer and distributor of grinding mill liners and screen media, amongst others and this gave us access to manufacturing capabilities and customers in Africa’s mining and industrial markets. Our facilities in South Africa also give us access to the member countries of the Southern African Development Community (SADC). We continued our expansion and acquired Chile based Tega Industries Chile SpA (formerly Acotec SA) (“**Tega Chile**”) in FY 2011 which is involved in the manufacture of pumps, screen media and wear products. Our facilities in Chile give us access to the South American markets including Chile, Peru and Bolivia (According to the F&S Report, Latin American countries contribute 40% of the global copper production and 8% of the global gold production output). In the same year, we also acquired Perth based Losugen Pty. Ltd. (“**Losugen**”) which specialized in the design, distribution, installation, wear monitoring of wear liners, rubber lining, screens for mining handling industries. We increased our market share in Australia by acquiring our competitor at the time, which gave us access to a ready platform to launch our conveyer accessories and screens in that market.

Our total income was ₹1,793.86 million, ₹8,566.84 million, ₹6,955.42 million and ₹6,430.13 million for the three months period ended June 30, 2021 and Fiscals 2021, 2020 and 2019, respectively. Our restated total profit for the period/year was ₹118.82 million, ₹1,364.05 million, ₹655.04 million and ₹326.70 million for the three months period ended June 30, 2021 and Fiscals 2021, 2020 and 2019 respectively. Our net cash generated from operating activities was ₹492.35 million, ₹1,702.46 million, ₹1,283.75 million and ₹686.69 million for the three months period ended June 30, 2021 and in Fiscals 2021, 2020 and 2019 respectively. Our EBITDA was ₹296.79 million, ₹2,386.42 million, ₹1,172.28 million and ₹1,060.03 million for the three months period ended June 30, 2021 and the Fiscals 2021, 2020 and 2019, having increased at a CAGR of 50.04 %, from Fiscal 2019 to Fiscal 2021. Our EBITDA Margin (EBITDA as a percentage of our total income) was 16.54%, 27.86%, 16.85% and 16.49%, respectively, in the same periods, having increased at a CAGR of 29.99%, from Fiscal 2019 to Fiscal 2021.

For Fiscals 2021, 2020 and 2019, our Return on Capital Employed (“**ROCE**”) was 24.76%, 11.17% and 11.12%. Our net worth was ₹6,311.52 million ₹6,137.22 million, ₹4,624.89 million and ₹4,011.05 million as on June 30, 2021, March 31, 2021, March 31, 2020 and March 31, 2019, respectively, while our Return on Equity (“**ROE**”) was 22.23%, 14.16% and 8.14% for the Fiscals 2021, 2020 and 2019, respectively.

## **Strengths**

***A leading producer of specialized and “critical to operate” products, with high barriers to replacement or substitution.***

Globally, we are the second largest producers of polymer-based mill liners in terms of revenues as of June 30, 2021, in a near oligopolistic market structure. (*Source: F&S Report*) We are present across the value chain of a mineral processing site, providing a wide range of products and solutions for processing across different stages of mineral processing.

Our products are critical to the overall productivity of a mineral processing site. They are a relatively low cost component in a unit’s operations, however, they play a critical role in determining a unit’s productivity, in terms of throughput, lower grinding media consumption, lower energy consumption and lower downtime, leading to lower operating costs for our customers. Downtime can be expensive for our customers at the mining sites, which leads to substantial losses to them.

In our experience, mineral processing sites do not tend to switch to a substitute supplier, even if the product offered by a new entrant or established substitute supplier is comparatively cheaper. This is due to the high cost of initial planning involved, the lead time required for approval, degree of certainty of the products of an established supplier, the high cost of downtime or shutdown of a site and relatively lower percentage cost of our components

in the total operating costs of a mineral processing site. Since mineral processing sites ordinarily refrain from switching and remain with an existing approved supplier, we have the flexibility to maintain high margins throughout the period of our association with a mineral processing site. It takes from nine months to one year to become an approved supplier at every customer site and once approved, these approvals do not have an expiry period.

Additionally, globally the industry in which we operate has limited number of established competitors. Following are some of our established competitors for certain of our products.

Products	Competitors
Mill liners	Metso-Outotec, Mc Elecmetal, Bradken, FL Smidth and Weir
Hydrocyclones	Weir, FL Smidth, Metso-Outotec, Schlumberger and Technip
Trommels and Screens	Multotec, Sandvik, FL Smidth and Metso-Outotec
Mineral processing equipment	Metso-Outotec, FL Smidth, Weir and Trelleborg AB

***Insulated from mining capex cycles, as our products cater to after-market spends, providing recurring revenues.***

Our products cater to the after-market spend of a mining processing unit. After-market spend is typically three times of the upfront capex spend over the lifecycle of a mill, and is a recurring cost for miners. After-market spend for a mining processing unit comprises regular operating expenses which include costs of wear and separation parts, grinding media, power consumption, liners and other regular operating expenses. As a result, 76.28%, 74.29%, 75.43% and 79.72% of our sale of products and services in three months period ended June 30, 2021 and last three Fiscals 2021, 2020 and 2019 resulted from repeat orders of spares.

Our focus end-customers are mineral processing sites involved in gold and copper ore beneficiation accounting for 34.92% and 27.25% respectively, of our revenue from sale of products. as an average of the last three Fiscals and 45.48% and 20.76% respectively of our sale of products for the three months period ended June 30, 2021. Gold and copper mill sites require superior quality of consumables and have higher beneficiation requirements. Across copper mines, ore grades have declined by around less than 1% per ton over the last few years. Similarly, ore grades have also depleted in the gold mines over the last few years, which has led to disproportionate industry growth of around 5-7% for mining and mineral processing equipment at each customer site. Also, decreasing ore grades has led to a greater demand for larger-sized equipment, leading to an overall growth of 17% of the mill lining industry in Fiscal 2021 (*Source: F&S Report*).

Despite some volatility in capital expenditure cycles for gold and copper mining sites, our business was not impacted, as a majority of our products were linked to the operating expenditure budget of a mining site and not capital expenditure.

***High value add and technology intensive products, backed by strong R&D and focus on quality control.***

Our in-house R&D and manufacturing capabilities, including design, process engineering and manufacturing facilities, allow us to turn around customized designs in a short time frame, offer comprehensive solutions and better service standards to our customers and cross sell multiple products to our customers. We design and customize our products uniquely for each customer site, taking into account multiple characteristics of the application including type of ore, ore size, tonnage, breakage rate, power or rotational speed, pH, temperature, humidity, size, distribution and trajectory, sound levels, health and safety standards. Our continuous design innovation makes our products highly engineered “built-to-suit” rather than “off-the-shelf”, with our products being unique for each customer site taking into account multiple characteristics of its application. We believe that this has contributed to attractive and sustainable margins, product innovation and optimum product design leading to our significant customer retention over the years.

We do not rely on outsourcing, which reduces our dependence on vendors, minimizes failure rates and facilitates our quality assurance. We believe our high-quality production and ability to match diverse customer specifications is due to our well-crafted manufacturing process. Our products which are sold to several major mining and mineral processing companies, which typically go through multiple stages of stringent selection and approval procedures, and have also been certified by various customers on quality assurance of our products. We undertake multiple stringent quality checks and have been awarded Integrated Management System (IMS) certification by SGS United Kingdom Limited, which are: Quality Management System (QMS) – ISO 9001:2015 (India, South Africa), Environment Management System (EMS) – ISO 14001:2015 (India) and Occupational Health & Safety Management System (OHSMS) – ISO 45001:2018 (India).

We have a track record of developing and commercializing a diverse and innovative product portfolio of 55 mineral processing and material handling products over the years, including DynaPrime launched by us in 2018. This product is targeted towards large mineral processing units which historically or conventionally had relied on traditionally used steel liners. DynaPrime has unlocked a new addressable market for us. As of March 31, 2021, our order book for DynaPrime includes 23 target sites. As of June 30, 2021, our order book for DynaPrime includes 28 target sites.

Our other recently launched precision technology value-added products include Rapido, also launched in 2018, which is an efficient screening machines used for separation of particles according to size, mosaic liners for chutes launched in 2016 and trommels launched in 2015. We believe our robust new product pipeline unlocks new market segments and offers significant growth potential.

Our strong in-house R&D has allowed us to register 8 global patents and several trademarks. With much of our capital expenditure having been incurred in prior years and our extensive sales and distribution network already set up, we are well positioned for future growth based on acceptance of our pipeline of new products across geographies.

***Long standing market player with marquee global customer base and strong global manufacturing and sales capabilities.***

We commenced operations with a foreign collobaration with Skega AB, Sweden in 1978. Over time, we have diversified our capabilities by expanding our product portfolio and augmenting our technical capabilities. Starting from one manufacturing facility in 1978, we have now grown to operate six manufacturing facilities across the globe.

We have a track-record of servicing leading global mining companies for a long period of time and in several cases, our relationships with key customers span more than 10 years, leading to high repeat revenues for us. Moreover, our deep relationships with some of the world’s largest senior miners and a robust order book of ₹3,161.36 million as of June 30, 2021 allow us significant visibility to plan for future growth.

We have Indian manufacturing operations at Dahej in Gujarat and at Samali and Kalyani in West Bengal, and our international manufacturing operations is in proximity to the world’s major copper and gold mining locations in Chile, South Africa and Australia, with a total built-up area of 74255 Sq. mts. Our extensive footprint across key mining belts worldwide has allowed us to enjoy economies of scale and logistical advantages and develop significant insight into our customers’ needs and market trends. Our sales and distribution network is also in-house, with 18 overseas and 14 domestic sales offices strategically located in all the key geographies close to key customers, supported by 155 member dedicated sales and servicing team with ability to assist pre sales and after sales services and in select geographies by commission agents from time to time.

In Fiscals 2021, 2020 and 2019, our India and overseas customer base included 513, 498 and 479 installation sites, respectively. Further, in the three months period ended June 30, 2021, our India and overseas customer base included 212 installation sites. The details of our customer base for the respective periods are set out below.

<b>Customer Base</b>	<b>Three months period ended June 30, 2021</b>	<b>FY 2021</b>	<b>FY 2020</b>	<b>FY 2019</b>
Domestic	98	255	239	215
Overseas	114	258	259	264
<b>Total</b>	<b>212</b>	<b>513</b>	<b>498</b>	<b>479</b>

We have an extensive global footprint across major global mining locations and supply our products across over 70 countries. Revenue from operations outside India constituted 84.48%, 86.42%, 85.92% and 85.83% of our total revenue from operations in the three months period ended June 30, 2021 and Fiscals 2021, 2020 and 2019, respectively. Our key overseas markets include North America, South America, Africa, EMER (Europe, Middle East and Russia) and Asia Pacific (South East Asia and Australia). The details of our revenue

Our in-house sales and distribution network in all the key geographies helps us with consistently adding new sites, leading to diversification of revenue stream across multiple sites and low concentration. As an average of the last three Fiscals, our top 10 customers accounted for only 29.19% of our revenue from operations in that period, while our top 20 and top 50 customers accounted for 42.11% and 65.30% of our revenue from sale of products



and services in that period, respectively and 34.19%, 52.75% and 78.08%, respectively for the three months period ended June 30, 2021.

The recurring nature of our business is supported by our expertise and sales reach. We offer to our customers our expertise in R&D, planning and operations and maintain constant dialogue, which results in better demand forecasting, provides insight into new business expansion and helps us plan for future growth with our customers.

We market our products primarily through the “plant audit” route (a specialized consultancy service that we offer to our customers across our product range). We believe in sourcing our customers directly, and maintaining on-going relationships and contact with them. Our direct sales model with dedicated regional teams also allows us to develop a deep understanding of our customers and leverage knowledge sharing between our sales and R&D teams for product development and provide personalized services resulting in a satisfied customer base, increased customer connect and loyalty.

The industry in which we operate is concentrated and characterized by strong presence of multinational customers, which have operations globally. However, decision making with respect to local operations for most of our customer sites is decentralised, which benefits us since we have established relationship with the operational teams through our dedicated regional teams. Our customer-centric approach has been one of the key reasons for our growth and profitability, and helps us differentiate ourselves from our competitors in the industry.

***Consistent growth, characterized by operational efficiency and high repeat business.***

Our business operated with 60.42%, 59.80%, 60.02% and 59.39% material margins (calculated as revenue from operations less cost of material consumed and change in inventories of finished goods and work-in-progress divided by revenue from operations x 100) and 16.54%, 27.86%, 16.85% and 16.49% EBITDA margins in the three months period ended June 30, 2021, Fiscals 2021, 2020 and 2019, respectively. Our strong market position and entry barriers helps us maintain high margins over time. Our business is capital efficient, with sale of products being 4.57 times of the property, plant and equipment (sale of products divided by net carrying value of property plant and equipment) for the Fiscal 2021 and ROCE of 24.76% for Fiscal 2021. Further, we have successfully maintained this operational efficiency while completing and integrating acquisitions, joint ventures and strategic alliances, including our acquisitions in Chile, South Africa and Australia.

Our repeat business from existing mineral processing sites accounted for 76.28%, 74.29%, 75.43% and 79.72% of our revenue from operations in the three months period ended June 30, 2021, Fiscals 2021, 2020 and 2019, each year and we are able to consistently add new customers and sites, on account of our value added offering focused on reduction of cost per tonne of processing and reduction of the downtime cost. Conversion revenue (i.e. revenue from new sites added in a year) accounted for 19.26%, 25.13%, 22.35% and 18.09% of our revenue from operations in the three months period ended June 30, 2021, Fiscals 2021, 2020 and 2019. Our net cash generated from operating activities was ₹492.35 million, ₹1,702.46 million, ₹1,283.75 million and ₹686.69 million in the three months period ended June 30, 2021, Fiscals 2021, 2020 and 2019 respectively.

With the launch of Dyna Prime, a composite liner of rubber and steel, we have expanded our addressable market to include larger sized equipment, offering greater productivity gains and cost savings to existing users of steel liners. As a result, our revenue from operation year on year increased by 15.52%, 8.06% and 17.62% in Fiscals 2019, 2020 and 2021 at a CAGR 12.74%, from Fiscal 2019 to Fiscal 2021. As of June 30, 2021, we have an order book of ₹3,161.36 million.

***Experienced management team supported by large, diverse and skilled work force.***

Our Promoter, Founder and Chairman, Madan Mohan Mohanka, is a civil engineer and first-generation entrepreneur with over 44 years of industry experience, and strong relationships with several key industry organizations. Our Promoter and Managing Director, Mehul Mohanka, who has been with our Company for over 18 years and is responsible for our overall corporate strategy, has a track record of successfully integrating multiple acquisitions across geographies, including Chile, South Africa and Australia. Mehul Mohanka is also serving or has served as chairpersons of key industry organizations, which strengthen our connect with our current and prospective customers.

We have an experienced Board, with an optimal mix of whole-time directors, independent directors and a nominee director of Wagner Ltd, each with several years of relevant experience. Our Board is supported by strong management and technical teams, which include individuals with specialized training and/or substantial

experience, including in operations, business development, quality assurance, customer relationships, finance and human resource management.

We have a team of experienced employees located in various parts of the world. Each of the global business units at Chile, South Africa and Australia are led by business heads in respective geographies, which provides a focused approach to each respective region. Our global workforce comprised of 1,698 employees (905 permanent and 793 contractual), 1,704 employees (906 permanent and 798 contractual), 1,693 employees (885 permanent and 808 contractual) and 1,619 employees (885 permanent and 734 contractual) as of June 30, 2021, March 31, 2021, March 31, 2020 and March 31, 2019, respectively. Out of our total white collar employees, we have over 151 engineers and other technical employees, with qualifications ranging between industrial training, undergraduate, graduate, post graduate and diploma levels. As on June 30, 2021, 22.44% of our workforce is overseas, divided into 18 dedicated regional teams. The diversity of our workforce allows us to optimally manage our overseas operations.

We also have a strong focus on training and retention of our employees and have implemented several training programs to improve employee engagement and productivity, including special training programs for shop floor level employees to prepare them for taking up large roles within our Company.

## **Strategies**

### ***Gain market share and customer wallet share across high growth markets.***

We are currently the second largest producer of polymer-based mill liners in the world, on the basis of revenues for calendar year 2020. (Source: F&S Report ) Across copper mines, ore grades have declined by around less than 1% per ton over the last few years. Similarly, ore grades have also depleted in the gold mines over the last few years, which has led to disproportionate industry growth of around 5-7% for mining and mineral processing equipment. Also, decreasing ore grades has led to a greater demand for larger-sized equipment, leading to an overall growth of 17% of the mineral processing consumables industry in Fiscal 2021. We intend to leverage this position to create opportunities in increasing our penetration and market share in North America, South America, Australia and South Africa.

For the period April to June 2021, our Indian and overseas customer base included 212 installation sites. In Fiscals 2021, 2020 and 2019, our India and overseas customer base included 513, 498 and 479 installation sites, respectively. We seek to capitalize on our track record of adding new customers and mining sites across geographies. Our direct sales model with dedicated regional teams is designed to ensure better responsiveness and customer retention. Our direct sales model ensures close interaction of our in-house sales and marketing team and our service engineers with our customers, thereby ensuring engagement in product development and therefore better serviceability.

Our client acquisition period has significantly reduced in new markets, especially in the U.S.A., Chile, Peru and Mexico. We plan to leverage our insights from these market entries to continue our expansion into other markets.

We also intend to leverage our strong product development, design, engineering and manufacturing capabilities along with our customer relationships to grow our share of customer wallets and improve our market penetration by cross-selling within our existing customer base. For instance, we have a focus not only on upgrading existing products, but also on developing product variants such as locking ceramic liner for medium impact and high wear resistant duty conditions and thin flexible ceramic liner application where the surface to be lined has a curved shape.

We also aim to strengthen our relationships with our existing customers by continuing our focus on high quality products and solutions which have recurring demand, leading to high repeat revenues. Furthermore, the scale of our operations across the mining and emerging industrial markets and materials handling industries allows us to offer a competitive cost structure and we intend to continue to leverage this advantage across the markets we serve.

### ***Leverage in-house R&D capabilities to grow our product offerings and capitalize on future trends.***

We plan to continue expanding our R&D capabilities in order to capture future growth trends. Our in-house R&D team comprising 36 personnel focuses on upgrading our existing products, developing product variants such as locking ceramic liner and thin flexible ceramic liner; development of new products such as Combi liner and wear resistant liners; and developing cutting edge new technologies, using our customised softwares for structural analysis, flow analysis, 3D modelling and product selection.

Further, we seek to continue to focus on our ability to customize our product offerings according to the specific requirements of our customers through innovation and focusing on sustainable solutions. We continuously seek to improve on our products to make them more effective for our customers and their applications and processes. We aim to innovate, manufacture and supply consumable products which will make the processes followed by our customers more efficient, more sustainable as well as more cost efficient. We also seek to continue to promote and strengthen our “plant audit” expertise, which is led by our R&D team.

We also continue to discern emerging trends and proactively identify new products with the use of our in-house software programs, leveraging our recent experience in launching products such as DynaPrime, Rapido and Combi-screen. Similar to our experience with DynaPrime, where a composite liner of rubber and steel, resulted in 50% increase in life of the liner compared to a traditional steel liner, we are continuing to work on introducing similar combination linings in single equipment to allow uninterrupted operations without downtime at our customers’ sites.

Our integrated capabilities enable us to capitalize on the growing opportunities and emerging trends in our industry, particularly in our wear products business, where our focus is on our flagship product, DynaPrime, which has unlocked a new addressable market for us in the last three Fiscals. Going forward, with DynaPrime, we seek to benefit from the key trend in the mill lining industry, which is moving towards the rubber-metal composite mill liners as against traditionally used steel liners.

#### ***Expand our manufacturing capabilities to achieve better economies of scale.***

We plan to continue expanding our manufacturing capabilities in order to capture future growth trends. In order to enhance our existing capabilities, we plan to expand our manufacturing capacity and capabilities, both in India and overseas. We are planning to expand our existing capacity at our Dahej and Samali facilities in India.

Further, as per the F&S Report, evaluating the growth trajectory in South America (which contribute 40% of the global copper production and 8% of the global gold production output), and to extend our access to and penetration with customers across Chile, Peru and Bolivia, we plan to set up a new manufacturing facility in Chile.

In addition, we plan to expand into life cycle management for our customers, with focus on capital equipment having high requirement of bespoke critical spares and services offered by us to increase our customer’s production efficiency and deliver sustained performance improvements. The life cycle management services would include, for example, preventive maintenance and optimization, which would enable overall process optimization for our customers.

#### ***Explore opportunities for inorganic growth.***

We intend to continue to actively pursue acquisitive opportunities and strategic alliances with targets that are complementary to our business. In particular, we will seek to make acquisitions that provide us with access to new technologies, or new customers, or new geographies.

We have a track record of successfully completing and integrating acquisitions and benefiting from our participation in joint ventures and strategic alliances, including our acquisitions in Chile, South Africa and Australia. Our acquisition agreements and joint ventures with strategically identified partners have allowed us to gain access to new customers and geographies and remain abreast with modern manufacturing techniques and equipment. For example, our acquisitions in South Africa gave us access to manufacturing capabilities and customers in Africa’s thriving mining and industrial market, while our acquisition in Chile gave us access to the South American markets including Chile, Peru and Bolivia and our acquisition in Australia gave us access to a ready platform to launch our conveyor accessories and screens in that market.

We seek to leverage our free cash flows to selectively evaluate complementary targets for strategic acquisitions, and continue exploring synergies that may arise from strategic alliances, partnerships or initiatives.

#### ***Operational efficiencies and margin expansion***

We intend to continue enhancing our operational efficiencies, to increase economies of scale, better absorb our fixed costs, reduce our other operating costs and strengthen our competitive position.

We have, in the past and intend to in the future, continue using a variety of other manufacturing strategies and cost reduction strategies to continue to improve our operational efficiencies. For example, to attain cost structure sustainability over the years, we emphasize on economies of scale and a robust supply chain developed for

sourcing of raw materials. To meet the growing demand from our customers, we have invested in our infrastructure, machines, equipment and technology to allow us to offer a diverse product suite, reduce operating costs and drive productivity and scale of our business without incurring significant incremental costs in the future. Our property, plant and equipment addition was ₹64.86 million, ₹243.29 million, ₹237.91 million and ₹244.30 million in the three months period ended June 30, 2021, Fiscals 2021, 2020 and 2019, respectively.

In addition, we shall also focus on cycle time reduction by adopting advanced technologies that will also result in process optimisation, thereby increasing our capacity to undertake more number of projects.

We avail of our fund-based and non-fund based facilities in the ordinary course of business from various banks and financial institutions. As part of our strategy, we intend to prepay/ repay, in full or part, of certain of our outstanding indebtedness. This will help reduce our outstanding indebtedness and debt servicing costs, assist us in maintaining a favourable low leverage and healthy capitalization metrics and enable utilisation of our internal accruals for further investment in business growth and expansion.

### **Impact of Covid**

The current outbreak of COVID-19 (“Covid”) pandemic has adversely impacted the global economy. The World Health Organization declared the outbreak of COVID-19 as a public health emergency of international concern on January 30, 2020 and a pandemic on March 11, 2020. The Government of India announced a nation-wide lockdown on March 23, 2020 and imposed several restrictions. Covid continues to spread across the globe and has since affected the world economy including India, leading to significant volatility and a decline in financial markets and general economic activity.

However, Covid had limited impact on the mining industry, since it was declared as an essential service in all countries globally. Mines were running continuously since temporary shutdowns of mines are expensive and therefore there was resilient demand for critical mining consumables for regular operations.

Since our products are critical to operate consumables for the mines, we were largely unaffected. Further, our plant in Chile remained functional with no halts in operations, our plant in South Africa had limited halt in operations, however our plant in Australia was impacted due to stricter and longer inter-boundaries lockdown within Australia, which has since been relaxed. Our strong customer profile, which includes senior miners and mining industries, were resilient during the period. However, we faced temporary logistical issues in terms of limited availability of labour, logistics and supply chain constraints. Our exports and production in some of our domestic facilities were temporarily disrupted from March 2020 onwards, across successive waves of national and regional lockdowns in India. Since then, we have resumed our operations in phases as per the Government of India and state government’s directives. Our plant utilization has improved, raw material suppliers have resumed operations and supply and logistics have become more regular. The future impact of COVID-19 or any other severe communicable disease on our business and results of operations depends on several factors including those discussed in “*Risk Factors – The extent to which COVID-19 affects our business, results of operations and financial condition will depend on future developments, which are uncertain and cannot be predicted*” on page 36.

### **Description of our Business**

#### **Our product portfolio**

Our product portfolio include consumables required in the mines and mineral processing industry. In the sequence of their usage in the mineral processing mines, after blasting to floatation, our products include chutes and its liners, grinding mill liners, trommels and screens, hydrocyclones, pumps and flotation parts and conveyor products. Our product range is engineered with a combination of mineral processing engineering, mechanical engineering and material sciences, while utilising our expertise in tribology.

In the three months period ended June 30, 2021 and Fiscal 2021, 2020 and 2019, our revenue from operations was ₹1,732.07 million, ₹8,055.22 million, ₹6,848.47 million and ₹6,337.57 million, respectively and our restated total profit for the period/ year was ₹118.82 million, ₹1,364.05 million, ₹655.04 million and ₹326.70 million, respectively. Our net cash generated from operating activities was ₹492.35 million, ₹1,702.46 million, ₹1,283.75 million and ₹686.69 million for the three months period ended June 30, 2021 and in Fiscals 2021, 2020 and 2019 respectively. Our EBITDA was ₹296.79 million, ₹2,386.42 million, ₹1,172.28 million and ₹1,060.03 million for the three months period ended June 30, 2021 and the Fiscals 2021, 2020 and 2019, having increased at a CAGR of 50.04%, from Fiscal 2019 to Fiscal 2021. Our EBITDA Margin (EBITDA as a percentage of our total income)

was 16.54%, 27.86%, 16.85% and 16.49%, respectively, in the same periods, having increased at a CAGR of 29.99%, from Fiscal 2019 to Fiscal 2021.

### **Mill liners**

Mill liners are used in the grinding mills for the beneficiation of minerals. The various types of mill liners we manufacture include DynaPrime, DynaSteel, DynaPulp and DynaWear, all of which are our flagship products.

#### *DynaPrime*

The DynaPrime range has been designed specifically for the bigger size of the mills where modern liner handlers are available. DynaPrime has been engineered to reduce the number of pieces being installed inside the mill, substantially reducing the installation downtime for maximum mill operation up-time. DynaPrime puts safety above all. Bolting from outside and lesser weight of the lining considerably reduces any risk during the installation of the liner.



#### *DynaSteel*

DynaSteel range constitutes of a combination of different alloys and rubber to engineer a perfect blend for grinding application. DynaSteel range ensures a complete protection from excessive wear on the mill lining and deliver maximum grinding efficiency to the mill. The lifting action transferred to the charge remains constant throughout the life of the lining. DynaSteel has proven to be successful in demanding applications, especially in primary grinding mills and the challenges faced by the conventional liners, such as cracking of liners is eliminated by the judicious use of the right material of construction in DynaSteel. The DynaSteel range is designed to be installed in large sized mills where modern liner handlers are not available.

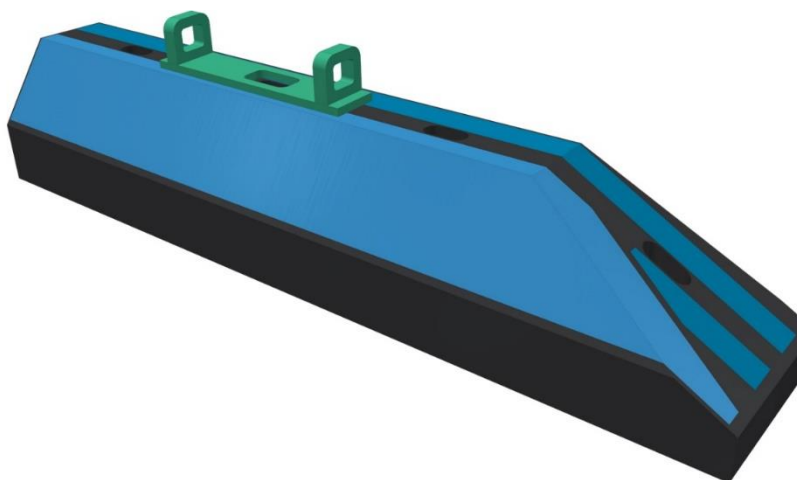

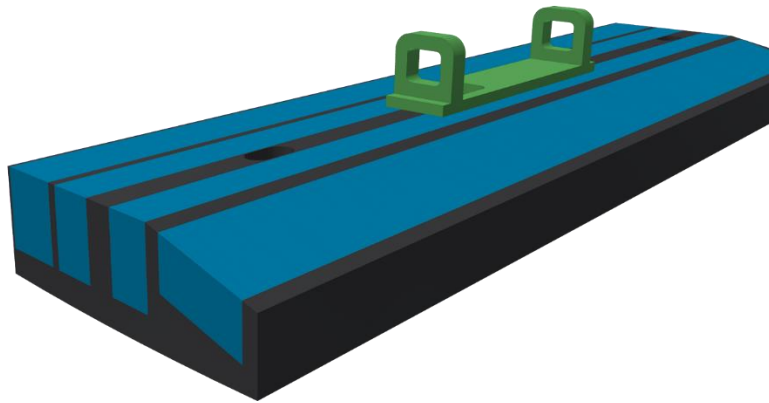

### *DynaPulp*

DynaPulp, along with our designed grate seeks to achieve a maximum capacity out of the mill. We use advanced computational softwares to simulate the slurry charge using specialized tools, to ensure an efficient discharge system. DynaPulp range has been proven to achieve a lower specific power consumption to save more energy. DynaPulp offers curved and radial discharger system. Curved discharger system ensures a maximum flow out of the mill eliminating carry-over. No back increases the mill capacity and also arrests excessive wear at the trailing edge of the discharger system, substantially increasing the life with minimum weight. Radial discharger system is engineered for both uni-directional and bi-directional mill rotation. Based on simulations and experiments, DynaPulp radial discharger system is designed with hardened steel at right positions to arrest excessive differential wear rate and thus maximizing the life of the discharger.

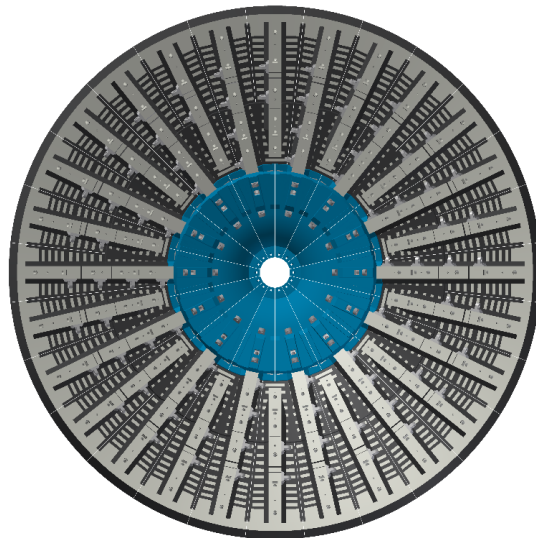

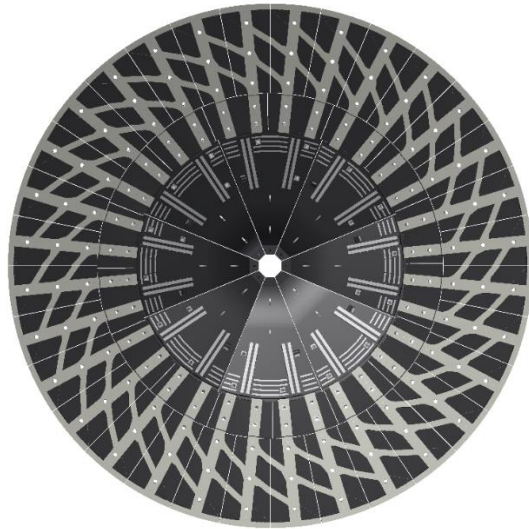

### *DynaWear*

DynaWear mill linings provide optimal grinding solutions in major mineral processing plants all over the world. DynaWear range consists of products completely manufactured using specialized rubber to deliver optimized life and capacity to maximize the cost benefit for a plant. Our rubber lining system is the preferred lining system for secondary ball mills; regrind mills, rod mills and scrubbers. DynaWear has been successfully used in a wide range and installed in primary, secondary and tertiary grinding mills, batch mills and scrubbers.

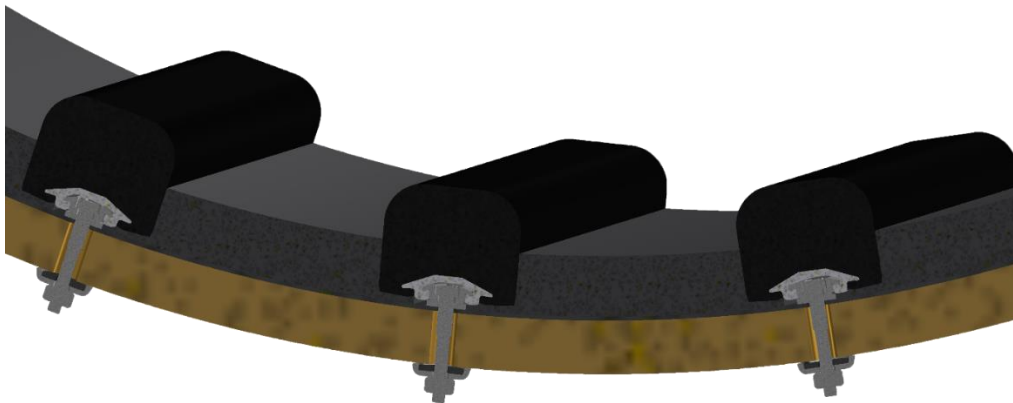

Growth drivers for our mill liners business includes a new opportunity in relation to replacement of mill liners in the semi-autogenous grinding (SAG) mills, where our DynaPrime range of mill liners are replacing steel liners due to its superior performance. Further, our DynaPrime range of mill liners will also benefit from secular growth trends applicable to other mill liners, sustained growth in the copper and gold commodity volumes and increased ore degradation.

### **Trommels and Screens**

Screens and trommels are used for separation of particles according to sizes. Our key products for the screens and trommels business includes Rapido.

### *Rapido*

Rapido is our patented product which addresses certain major issues of the mining industry relating to clogging and blinding of the apertures during operation with existing screen panels, resulting in downtime of the equipment



and lower efficiencies. With its dual system of top and bottom part, it reduces the replacement time of panels substantially and due to the unique patented top part, induces secondary vibration in the panel which results in the elimination of blinding and clogging. It therefore increases the efficiency of the panels, resulting in significant benefits to the customer.



### *Screening Solutions*

We provide screen applications in mining, mineral processing, steel plants and aggregate industries. Our screening solutions deliver unique, highly efficient wear resistant screen decks which increases screening efficiency, reduces down-time and cost per tonne of material handling. Some of our popular screening decks include, bolt down panels, cross tension panel, flip flo panel, panel cord, dewatering panel, polysnap panel, anti-clogging panel and button type panel.



### *Trommels*

Trommels are becoming an integral part of large SAG mills application. The high tonnage mineral processing plants have replaced screens with high capacity trommels to handle high tonnage of ore processed and to efficiently separate the oversized particles. Therefore, trommels have eliminated the need of having multiple screens in a mineral processing plant and assure uniformity of separation. With our engineering expertise in designing and installing consumables for large sized mineral processing plants, we offer a wide range of trommels for heavy duty, medium duty and light duty applications along with structure, rubber or polyurethane screen panels, spirals, connecting pieces and end flanges. All our trommels are custom designed, optimizing the sizes,



capacity and wear life. The structural parts, type of panels, fixing type and reinforcement are designed and manufactured on the basis of application. The structural design is cross checked and optimized with our specialized analysis. All the structural parts are covered with rubber coating to resist corrosion. The trommel screen panels are either rubber or polyurethane based, depending on the application and consists of totally embedded mild steel reinforcement to support the load and maintain the curvature of the panels.



## **Hydrocyclones**

Hydrocyclones are used for extracting or separating slurry particles, based on the overall particle weight while consuming relatively lower power. Our key product for our hydrocyclones business is the Tega Cyclone.

### *Tega Cyclone (PExEL)*

Our range of cyclones are made entirely from highly wear resistant rubber/ Cryston and are housed in mild steel casing. These are available with multiple cone angles to suit Customer requirement. Tega cyclones work in almost every mineral industry such as iron, coal, alumina, clay and many others and are used extensively for mineral classification and beneficiation of ore minerals. We market our Tega Cyclones on the basis of their high capacity per unit area and flexibility.



### Conveyor Products

Our conveyor products include conveyor components used with conveyor belts. Our key conveyor products include Spill-ex skirt sealing system, Centrax, and ceramic pulley lagging.

#### *Spill-ex skirt sealing system*

Our spill-ex skirt sealing system is simple, yet effective in making conveyor loading stations spillage free. Skirt sealing is generally provided on both sides of the skirt board, however, for conveyors that are inclined upwards or for those handling fines, sealing of the rear of the belt is necessary. Our Spill-ex skirt sealing system is used in the loading zones of belt conveyors. Rear skirt sealing is provided with a fixed length backing skirt plate that is based on belt width.



### *Centrax*

Centrax is used to guide the conveyor belt system, when the conveyor belt starts to mistrack and the speed of the two tapered rollers changes. When there is a difference in speed, Centrax belt trackers immediately engage and guide the conveyor belt back to its correct position. The combination of tracker rollers with strong grip and a smooth-running swivel bearing gives Centrax its precision tracking characteristics.



### *Ceramic Pulley Lagging*

Lagging of the conveyor pulley is essential to improve conveyor belt performance. The use of lagging reduces belt slippage, improves tracking and extends life of belt, bearing & other components. Our ceramic pulley lagging is especially suited for pulleys with slippage and excessive wear and tear problems which make normal rubber lagging ineffective. Our ceramic pulley lagging is widely used on the drive pulleys and can also be used on snub, bend and tail pulleys. This product incorporates square ceramic tiles with unique circular nubs which help in proper grip of the belt under wet muddy or any such arduous conditions.

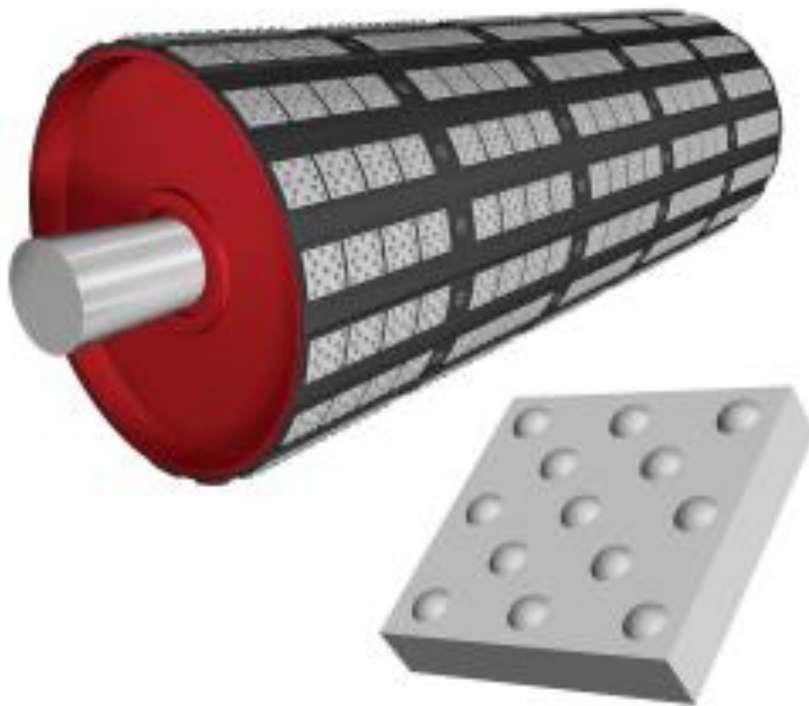

### Services segment

Our services segment offering ranges from undertaking specialized plant audit consultancy service that we offer to our customers for grinding and classification upgrades, supplying individual spare parts, to comprehensive solutions covering maintenance and operations. We focus on creating unique solutions to enhance the performance and productivity of our customers' plants and equipment throughout their entire lifecycle.

Our revenue from sale of services was ₹57.72 million, ₹131.82 million, ₹133.66 million and ₹191.00 million in the three months period ended June 30, 2021 and Fiscals 2021, 2020 and 2019 respectively.

### Manufacturing Facilities

The following map shows the locations of our manufacturing facilities and sales and marketing offices, both in India and overseas



*Note: Map not to Scale.*

We own and operate six strategically located manufacturing facilities across the globe, including three in India, in Dahej in Gujarat and at Samali and Kalyani in West Bengal, and three in the major global mining locations of Chile, South Africa and Australia, with a total built-up area of 74255 Sq. mts.

Our facilities are located close to mining and emerging industrial markets and material handling industries, allowing economies of scale and logistical advantages for our customers, and to insulate them from local supply or other disruptions. We do not outsource any of our products, unlike certain of our competitors, which reduces out external dependencies and adds to our ability to turnaround customized designs in a short timeframe.

The following table sets out certain details of our manufacturing facilities:

S. No.	Facility location	Capabilities/ Products manufactured	Leased/owned	Year of Commissioning/ Acquisition
<b>A. Domestic Facilities</b>				
1.	Dahej, Gujarat	Mill liners, Wear products, Screens and Trommels	Leased	2013
2.	Samali, West Bengal	Mill liners, Wear products, Hydrocyclones, Screens, Trommels and Conveyor products	Owned	1985
3.	Kalyani, West Bengal	Mill liners (except DynaPrime), Conveyor products, Chute liners and pump liners, Hydrocyclones	Leased	1978
<b>B. Overseas Facilities</b>				
4.	Chile	Mill liners, Trommels, Chute liners, Screens, Pipe and pipe repair and spools	Leased	2011
5.	South Africa	Mill liners (except DynaPrime), Spillex, Screen Panel, Chute liners	Owned	2006
6.	Australia	Chute liners and Trommels	Leased	2010

The following table sets forth certain information relating to our capacity utilization of our high tonnage press capacity at certain of our manufacturing facilities, calculated on the basis of total installed capacity and actual production for the periods indicated below:

Location	Fiscal 2021			Fiscal 2020			Fiscal 2019		
	Installed Capacity in MT*	Actual Production in MT*	% Utilization	Installed Capacity in MT*	Actual Production in MT*	% Utilization	Installed Capacity in MT*	Actual Production in MT*	% Utilization
Dahej	9,633	4,899	51%	8,538	5,485	64%	8,173	4,391	54%
Samali	6,449	3,897	60%	6,449	2,859	44%	6,449	2,976	46%
Kalyani	2,008	1,430	71%	2,008	1,616	80%	2,008	1,707	85%
South Africa	3,192	1,643	51%	3,192	1,219	38%	3,192	1,049	33%
Chile	3,276	2,400	73%	2,490	1,800	72%	1,164	1,125	97%
<b>Over all</b>	<b>24,558</b>	<b>14,269</b>	<b>58%</b>	<b>22,677</b>	<b>12,979</b>	<b>57%</b>	<b>20,986</b>	<b>11,248</b>	<b>54%</b>

\*Metric Tonne

Notes

- The Press Capacity given above and also the Actual production in FY 19, FY 20 & FY21 are for large size presses where mill liners are manufactured.
- The products manufactured other than mill liners have different manufacturing process routing including a mix of manual and equipment based processes, and hence estimation of capacity utilization for these products is difficult to be validated.
- The actual production for the 3 financial years shared is on the basis of the compound and the reinforcements that have been consumed in the presses mentioned for each of the plant for manufacture of mill products
- The above data is shared for the plants where manufacturing of mill liners are taking place. The products manufactured in these plants are either shipped directly to the customer, or through other subsidiaries of the company. From these subsidiaries, the products get shipped to the end customer in as is condition as well as some value additions based on specific customer requirements.
- The above does not include Unit located in Australia as it is an assembling unit of the Company

#### Quality Assurance within our manufacturing facilities

All our products are manufactured following our standard operating procedures for each category of our products. At each stage of the manufacturing process, inspections of the components and the final product is carried out, following our standard quality assurance procedure. All the manufacturing parameters, control and testing devices are checked and calibrated with higher frequency.

All incoming components such as elastomer components, aluminium and wear resistant steel and adhesive are passed through standard testing and verification procedure according to related quality assurance procedure. Related documents and test results are reviewed and after meeting the specified limits, are allowed to be used in the process line. Further, all process parameters such as adequate degreasing of wear resistant steel and aluminium

track, subsequent surface preparation, cleanliness, required texture as per the standards, proper priming and cementation by adhesive with proper viscosity and coated film thickness are verified in accordance with the quality assurance procedure.

The quality assurance team carries out frequent checks on the process and product specifications as per our quality assurance plans, prepared and issued by the technical team. Further, the finished products, which are approved by the quality assurance team are passed on for finishing and inspection which ensures that the product meets industry standards.

We undertake multiple stringent quality checks and have been awarded Integrated Management System (IMS) certification by SGS United Kingdom Limited, which are: Quality Management System (QMS) – ISO 9001:2015 (India, South Africa), Environment Management System (EMS) – ISO 14001:2015 (India) and Occupational Health & Safety Management System (OHSMS) – ISO 45001:2018 (India). We have currently applied for ISO certification standard 9001:2015 for our facility in Chile, which is currently pending.

### **Manufacturing Processes and capabilities**

Our end-to-end in-house manufacturing capabilities, including design, process engineering and manufacturing facilities including banbury mixer, extruder, metal preparation and press shop, allow us to offer comprehensive solutions and better service standards to our customers for the beneficiation of various ores and mineral products.

We have well defined systems and processes with the ability to design our softwares internally for product development and other applications. We have our internal technical teams with strong technical expertise to customize solutions in accordance with the requests from our customers

Following is a brief description of the manufacturing process undertaken at our facilities:

#### *Rubber Mixing and Blanking*

Rubber compound forms a very important ingredient for our range of products. Both natural as well as synthetic rubber is mixed with additives as per compound formulation. The same is done in banbury mixer. Banbury output is then taken through secondary mixer or extruder for usage in further upstream processes.

#### *Fabrication*

Metal processing is done in Fabrication using normal mild steel in plates form as well as structural steel form and also special grade steel. The output is reinforcements or welded structures made as per engineering design to suit the product requirement.

### **Blasting and Cementing**

Blasting is a process for metal surface preparation required for the adhesive or cement to be applied. We have both, air assisted manual shot blasting as well as airless automated blasting.

The blasted products are quality inspected for desired surface roughness and then taken for the next process i.e. Cementing. Here coats of adhesive is applied. First the primary coat is applied and allowed to dry. Subsequently the top coat is applied and allowed to dry.

#### *Press Compression Molding*

The output from both the blanking section and cementing section brought together and then in specially designed molds are subjected to compression molding as high temperature. This ensures vulcanization of the rubber compound and at the same time metal to rubber compound adhesion takes place.

#### *Finishing and Checking*

The output from the molding process is then taken for finishing operations. After the finishing operations, jig checking is done to ensure fitment accuracy at customer site.

### Quality Approval Plan and Quality Control

Throughout the entire process from input to finished goods inspection, each product is subjected to a quality check at each process step. At critical to quality steps, certain extra check points are done both on the shop floor as well as quality labs.

### Packaging and Dispatch

After the pre-delivery inspection, the products are packed in specially designed wooden crates and boxes. These boxes are carefully marked with identification as well the customer reference number and stored systematically for dispatch.

Our manufacturing process is as set out below:

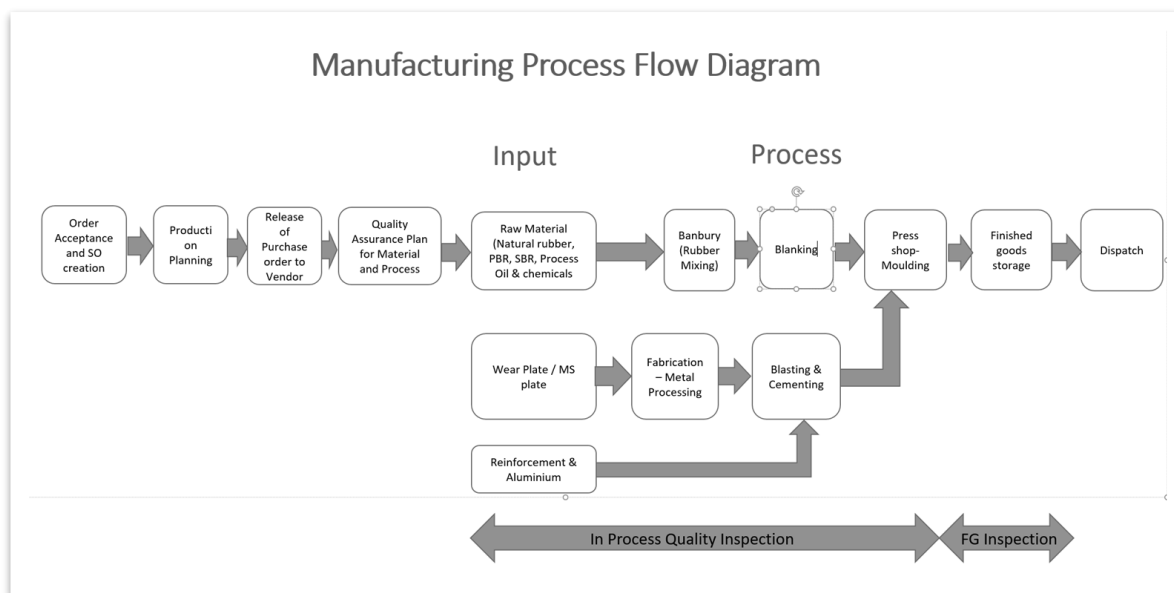

### Raw Materials and Procurement

The raw materials used for the manufacturing of our products are predominantly divided into two categories, i.e., rubber compounds and reinforcement. The primary raw material used in rubber compounding, which is an intermediate raw material, include carbon black, high grade natural rubber, polyurethane rubber and styrene-butadiene rubber, while reinforcements include wear plates, castings, aluminium and other alloys. The majority of the raw materials used to prepare rubber compounds are procured locally in India and is delivered to all our overseas manufacturing locations based on the plan and order book, to maintain uniformity in the quality and consistency.

#### Carbon Black

We currently procure carbon black requirement locally from three approved suppliers in India with production facilities distributed across India.

#### Polybutadiene Rubber ("PBR")

We currently procure our PBR requirement from Singapore and France and from Asian countries such as South Korea. There are no near term plans to source PBR locally as the special grade of PBR required for our rubber compounds are not manufactured in India.

#### Natural Rubber

We currently procure our natural rubber requirement locally from Kerala and also imported from Vietnam. We have two local and two overseas suppliers. Natural rubber being a traded commodity, we purchase it at the prevailing market rates and do not have long term rate based contracts.

### *Styrene-butadiene Rubber*

We currently procure 100% of our Styrene-butadiene rubber requirement locally from two sources. Although we have four global approved sources, since our current requirement for styrene-butadiene rubber is limited, we currently only rely on local procurement to meet our demand.

### *Wear Plates*

We currently procure 100% of our wear plates requirement from Sweden and Germany. We typically negotiate the rates with major manufacturers for all our manufacturing units, however the individual supply requirement and procurement is undertaken by the respective manufacturing units. There are no near term plans to source wear plates indigenously.

### *Castings*

The procurement of castings by each of our manufacturing facilities is done locally by us, however for certain high risk orders at our Indian facilities, castings are imported from Spain. Castings are a make to order commodity for us, sourced based on the customer orders. We typically have long term contracts for domestic castings, which are linked with the commodity indices and the conversion cost and the delivery lead time is fixed.

### *Aluminium*

The procurement of aluminium for our Indian facilities is done locally from five local suppliers. The charges for conversion are fixed for one year with all our suppliers and the rates are linked with certain reputable Indian aluminium manufacturer's price list. The procurement for our South African facility is undertaken from two suppliers.

## **Customers**

Our diversified customer base includes marquee Indian and multinational mining companies, as well as small and medium-sized companies in the mining and minerals beneficiation industry in emerging regions. As of June 30, 2021, our domestic and overseas customer base included 212 mining sites. Our relationships with certain of our key customers span more than 10 years.

We have a direct relationship with the majority of our customers, including our overseas customers, with the exception of a few customers we deal with through certain dealers/ agents. 98.23% of our business for Fiscal 2021 is from our direct relationship with customers and 97.48% of our business for the three months period ended June 30, 2021 is from our direct relationship with customers. We have both long term contracts with, and quotation based orders from, our customers. Our long term contracts typically range for a period between two to three years and the agreed upon price is fixed at the time of entering into the contract with certain pre-agreed escalation formulae which captures the increase in raw material price. These prices are mutually discussed and validated at the beginning of every year. Our quotation based orders from our customers are undertaken by way of providing spot quotations upon request based on the current raw material prices. Further, within reasonable limits, we escalate the price of our products based on the input prices and therefore most of the orders we receive are covered by the pass-through provisions for raw material pricing.

As an average of the last three Fiscals, our top 10 customers accounted for 29.19% of our revenue from sale of products and services in that period, while our top 20 and top 50 customers accounted for 42.11% and 65.30% of our revenue from sale of products and services in that period, respectively and 34.19%, 52.75% and 78.08%, respectively for the three months period ended June 30, 2021.

Since our products cater to the after-market spend of a mineral processing unit, which is a recurring cost for our customers, 76.28%, 74.29%, 75.43% and 79.72% of our sale of products and services in the three months period ended June 30, 2021 and Fiscals 2021, 2020 and 2019 resulted from repeat orders from our existing customers.

### *Case Studies*

#### *Case Study Product – DynaPrime*

*Problem:* Large sized mills using traditionally used steel liners had a lower liner life leading to higher installation downtime. Higher downtime accounted for unplanned shutdown leading to lower reliability. Further, constant replacement of steel liners also had concerns relating to installation safety.



*Our solution:* Upon critical examining of the dynamics of the mill, we offered DynaPrime, with its improved profile and material composition to cater to higher life. DynaPrime was designed with lesser number of pieces and fixing points which ensured faster installation. We incorporated new design with bolting from outside and lesser weight of the lining which eliminated the risk during the installation of the liner.

*Result:* Introduction of DynaPrime in designated mill resulted in increase in life of the line. Further, there was a decrease in the number of pieces installed, the total weight of the liner and the number of bolts installed. Also, the installation time of DynaPrime in a mill was lesser than the traditional steel liners, which led to a subsequent reduction in installation manpower. The overall power consumption also reduced per year in DynaPrime installed mills.

DynaPrime had a multi-faceted advantage over the traditional steel liners used in the large sized mills which led to an increase in asset productivity, reduction of operating expenses, reduction of risk, improvement in safety and improvement in environment sustainability. Following are the key advantages of DynaPrime.

Increase Asset Productivity	Reduce Operating Expenses	Reduce risk	Improve Safety	Improve Environmental Sustainability
Increase mill availability to process more ore	Lower maintenance cost	Do away with unplanned shut-down	Installation from outside.	Lower CEE required, enabling reduction in carbon footprint
Increase mill operation time as a result of faster relining	Lower energy expenses	Better liner profile stability throughout the campaign		Reduces the environmental contamination
Increase life as per plant requirement	Less personnel required for installation			
Increase ball charge volume due to decrease in liner weight	Faster reline due to lesser number of fixings for liner installation			

*Case Study Product – Chute*

*Problem:* Gold mines in Canada suffered from uneven distribution of mill discharge. Our objective was to get an even distribution of mill discharge with solid reporting on each outlet.

*Solution:* Upon critical examination, it was understood that the percentage of solid distribution was uneven between two feeder boxes and as a result the screens downstream were either underfed or overfed. We offered our new tapered discharge chute, with its improved design and a rock box kind of arrangement.

*Result:* Our chute resulted in an almost even split as desired for the circuit. Further, the liner selection was optimised to suit the new design and maximise the liner life. This resulted in the overall improvement in the performance and the increased downstream circuit efficiency.

*Case Study Product – Trommel*

*Problem:* Copper mines suffered from regular shutdowns due to the short life of the trammel panels. Our objective was to improve the life of the trommel panel for greater productivity.

*Solution:* Upon critical examination, it was understood that the design of the panel was not in line with the wear rate based on the operating conditions. Therefore, the design of the panel was optimized to counteract the wear rate with an improved panel.

*Result:* Our heavy duty rubber trommel panels optimized for each specification resulted in an increase of the life of the panels and a reduction in the number of shutdowns per annum and the cost per tonne of the trammel panels.

*Case Study Product - Centrax*

*Problem:* Iron ore mines in India suffered from frequent tripping, due to exaggerated belt sway which resulted in unscheduled shutdown to clean the spillage. Our objective was to control the belt sway, stop unscheduled shutdowns and eliminate the damage to the belt and the structure.

**Solution:** Upon critical examination, it was understood that the tripping was due to the high belt sway. The belt was analysed section wise to identify the starting points of sway and Centrax was offered in identified locations to arrest the belt sway.

**Result:** Centrax resulted in reduction of the belt sway, which reduced the number of instances of tripping of the belt per month. The reduced belt sway also increased the belt life and provided an annual saving to the customer.

## Sales and Marketing

We also have 18 global and 14 domestic sales offices located close to key customers. We have a sales and services team, comprising 155 full time employees, who are responsible for carrying out promotional and brand building activities for our products, including meets with and direct mailers to our customers. Our in-house sales and distribution network in all the key geographies helps us with consistently adding new mill sites.

The region wise bifurcation of our sales and services team, comprising 155 full time employees, as on June 30, 2021, is as follows:

Region	Number of employees as on June 30, 2021
India	93
Africa	17
Asia Pacific	13
South America	12
North America	11
EMER	9

We have dedicated sales teams and key account managers that are responsible for consolidating our relationships with key customers and developing strategies to ensure that we are engaging in projects and developing the right products in line with our business growth and market trends.

We market our products primarily through the plant audit consultancy route. We source our customers directly, and maintain on-going relationships and contact with them. Our direct sales model with dedicated regional teams for sales and marketing also allows us to develop a deep understanding of our customers and leverage knowledge sharing between our sales and R&D teams for product development and provide personalized services resulting in a satisfied customer base, increased customer connect and loyalty. Our customer-centric approach has been one of the key reasons for our growth and profitability, and helps us differentiate ourselves from our competition.

## Research and Development

As on June 30, 2021, our in-house R&D team comprises 36 personnel who focus on upgrading our existing products, such as heat resistant grade rubber and fire retardant anti-static; developing product variants such as locking ceramic liner and thin flexible ceramic liner; development of new products such as Combi liner to withstand high energy impact and wear resistant liner; and developing cutting edge new technologies such as combination lining in new technologies.

We offer our engineering capabilities and experience in manufacturing to develop the best-suited products for our customers. With a focus on international markets, we seek to continuously innovate and upgrade our product and service offerings. As many of our products are proprietary in nature, we continually work on developing innovative, lean and cost competitive designs to maintain a technological edge across product range. Our R&D team not only looks at introducing new products in the market but also on upgradation of our existing products.

We are constantly engaged in R&D and have a special team which is engaged in the development of new products and services with a key objective to deliver solutions. Our team of engineers visit customer sites frequently to find solutions to the threats faced by them. Our extensive research activities, advanced R&D centers and innovation keeps us at the forefront in the industry.

The following table sets forth our R&D expenditure in absolute terms and as a percentage of our total expense for the periods indicated:

	Fiscal 2019	Fiscal 2020	Fiscal 2021	(₹ in millions) Three months period ended June 30, 2021
R&D expenditure	42.42	36.68	37.52	9.84

	Fiscal 2019	Fiscal 2020	Fiscal 2021	Three months period ended June 30, 2021
% of total expenses	0.71%	0.57%	0.56%	0.60%

### Human Resources and Employee training

Our global workforce comprised of 1,698 employees (905 permanent and 793 contractual), 1,704 employees (906 permanent and 798 contractual), 1,693 employees (885 permanent and 808 contractual) and 1,619 employees (885 permanent and 734 contractual) as of June 30, 2021, March 31, 2021, March 31, 2020 and March 31, 2019, respectively. which includes 579 white collar employees, 326 blue collar employees and 793 contract workforce. Out of our total white collar employees, we have over 151 engineers and other technical employees, with qualifications ranging between industrial training, undergraduate, graduate, post graduate and diploma levels.

As on June 30, 2021, 22.44% of our workforce is overseas, divided into 18 dedicated regional teams. The diversity of our workforce allows us to optimally manage our overseas operations.

Our personnel policies are aimed towards recruiting talented individuals, facilitating their integration, and promoting the development of their skills. These employees are employed in various capacities across our divisions, which range from such professionals like that of engineers, accountants to machine operators and workers. Recruitment of personnel in different categories is carried out by the human resources department of our Company. We also provide training to our employees. Our emoluments for our staff are performance based. Employees are evaluated on a yearly basis for their performance on specified parameters.

The following table illustrates the breakdown of the numbers of our employees, including contract workmen, by function as of the dates indicated:

Function	As of March 31			Three months period ended June 30, 2021
	2019	2020	2021	
Operations	1222	1282	1274	1,261
Global Marketing	102	106	111	117
Sales and Service	159	164	158	155
Finance and IT	57	60	58	56
Other G&A	79	81	103	109
<b>Total</b>	<b>1619</b>	<b>1693</b>	<b>1704</b>	<b>1,698</b>

### Insurance

Our operations are subject to various risks inherent in the industry as well as theft, natural disasters, spread of communicable diseases, acts of terrorism and other unforeseen events. We maintain insurance cover for our Company as well as our manufacturing facilities, and our policies cover, among others, protection from fire, special perils, burglary, machinery breakdown, plant and machine and a variety of marine and employee insurance policies such as group personal accident policy and workmen compensation policy. We also maintain insurance for our directors' and officers' liability up to a limit of ₹100 million for any one claim or in the aggregate for all claims made.

We generally insure our assets based on their replacement value, which is generally higher than the carrying value of our assets in our financial statements. Notwithstanding the above, our policies are nonetheless subject to standard limitations. For example, in the case of business interruption, limitations apply with respect to the length of the interruption covered and the maximum amount that can be claimed. Therefore, insurance might not necessarily cover all losses incurred by us and we cannot provide any assurance that we will not incur losses or suffer claims beyond the limits of, or outside the relevant coverage of, our insurance policies. See **“Risk Factors – Our insurance coverage may not be adequate to protect us against all potential losses, which may have a material adverse effect on our business, financial condition and results of operations.”** on page 55.

### Information Technology

Our IT systems are aligned with our business strategy and is vital to our business. Its key objectives are speed, agility, adaptability and scalability in development as well as service and collaboration. The key focus areas are protecting intellectual property rights, mitigating cyber and business continuity related risks, improving efficiency, increasing digitalization and automation, leveraging the value of data and ensuring availability of skills

and resources. The key functions of our IT team include establishing and maintaining enterprise information systems and infrastructure services to support our business requirements.

We have made conscious efforts to consistently upgrade our systems to ensure efficiency and reduce redundancies. We have taken necessary measures for ensuring cyber security, data protection from virus attacks and hacking and disaster recovery servers and systems for data retrieval and business continuity. The application landscape consists of modern technologies such as SAP as ERP for accounting, procure to pay, order to cash, manufacturing and planning, quality management and plant maintenance, SAP SuccessFactor for Human Capital Management (HCM) and many softwares such as SAP Concur and in-house developed service applications. We are also in the process of implementing SalesForce as CRM.

### **Property**

Our Company's registered office is located at 147, Block-G, Humayun Kabir Sarani, New Alipore, Kolkata 700 053, West Bengal, India and corporate office is located at Office Space No. 807, 8<sup>th</sup> Floor, Godrej Waterside-Tower II, DP-5, Bidhannagar, Salt Lake, Sector V, Kolkata 700 091, West Bengal, India. Our registered and corporate office properties are leased by our Company.

Except for our facilities in Samali, West Bengal and South Africa, which are owned, all other facilities in India and overseas are primarily leased from third parties including the West Bengal Industrial Infrastructure Development Corporation for periods ranging from 30 years to 99 years. For details see, “ – *Manufacturing Facilities*” above.

### **Intellectual property**

Our Company has registered our name and/or logo,  “tego” in 12 foreign jurisdictions including, the European Union, Canada, South Africa, Chile, and Australia with the relevant trademark registration authorities in such jurisdictions. In India, as on date of this Red Herring Prospectus, our Company has registered several trademarks, including word marks and device marks, under various classes such as class 6, 7, 17, 35, 37 and 42 with the Registrar of Trademarks under the Trademarks Act. In addition, several applications for registration of trademarks have been filed by us in India which are pending.

Further, as on date of this Red Herring Prospectus, we have been granted 8 patents in relation to our products such as improved screen panel and ceramic chute liner in several jurisdictions including India, United States and South Africa. We also have 4 pending patent applications submitted before the Office of the Controller General of Patents in India. We expect to continue to file patent applications seeking to protect our innovations and novel processes, both in developed markets and emerging markets. Existing or future patents granted to us may provide some competitive advantages for our products, however, they may also be challenged, invalidated or circumvented by our competitors. For details, see “*Risk Factors- Our efforts in obtaining and protecting our patents may be costly and unsuccessful, which may have an adverse effect on our business and results of operations.*” on page 40.

For further information on the intellectual property of our Company, see “*Government and Other Approvals*” beginning on page 359.

### **Corporate Social Responsibility (“CSR”)**

Our CSR initiatives are aligned with the requirements under the Companies Act 2013 and the Companies (Corporate Social Responsibility) Rules, 2014. We strive to meet our commitment towards the community by committing our resources and energies to social development.

In Fiscals 2021, 2020 and 2019, we spent ₹27.26 million, ₹7.51 million and ₹0.96 million, respectively, on CSR activities. We have implemented several CSR initiatives on our own, with employee volunteers as well as in partnership with implementing agencies from time to time. We have identified six focus areas of engagement in CSR activities which are as under:

- Health: Affordable solutions for healthcare through improved access, awareness and health seeking behaviour;
- Education: Access to quality education, training and skill enhancement;

- Protection of National Heritage, Art and Culture: Protection and promotion of India's art, culture and heritage;
- Rural Transformation: Creating sustainable livelihood solutions, addressing poverty, hunger and malnutrition; and
- Environment: Environmental sustainability, ecological balance, conservation of natural resources.

We closely monitor the progress of various CSR activities at different sites to ensure the impact of these initiatives. Our senior management also interacts with the CSR teams at our different sites through regular updates and site visits. Our prime objective is to give back to society in a way that brings positive changes and transforms the lives of the weaker sections in the best possible ways.

### Competition

The industry in which we operate is sophisticated

and characterized by strong presence of multinational companies. Given the nature and breadth of our product and service portfolio, we have a limited number of competitors globally, however, we face competition, both domestically and internationally, and from organized as well as unorganized players. The key factors of competition include quality, distribution network, pricing, timely delivery, product development and management and industry relationships. Typically, marquee domestic and global mining companies work only with a limited number of players. Following are some of our established competitors for certain of our products:

Products	Competitors
Mill liners	Metso-Outotec, Mc Elecmetal, Bradken, FL Smidth and Weir
Hydrocyclones	Weir, FL Smidth, Metso-Outotec, Schlumberger and Technip
Trommels and Screens	Multotec, Sandvik, FL Smidth and Metso-Outotec
Mineral processing equipment	Metso-Outotec, FL Smidth, Weir and Trelleborg AB

## KEY REGULATIONS AND POLICIES IN INDIA

The following description is a summary of certain sector specific laws and regulations in India, which are applicable to our Company. The information detailed in this chapter has been obtained from various statutes, regulations and/or local legislations and the bye laws of relevant authorities that are available in the public domain. The description may not be exhaustive, and is only intended as a substitute to provide general information to investors, and is neither designed, nor intended as a substitute for professional legal advice. Judicial and administrative interpretations are subject to modification or clarification by subsequent legislative, judicial or administrative decisions. For further details in relation to our material approvals, see “**Government and Other Approvals**” beginning on page 359.

### Key Acts, Regulations and Policies governing our Company

#### **Legal Metrology Act, 2009**

The Legal Metrology Act, 2009, as amended (the “**Metrology Act**”), was enacted with the objectives to establish and enforce standards of weights and measures, regulate trade and commerce in weights, measures and other goods which are sold or distributed by weight, measure or number and for matters connected therewith or incidental thereto. The Metrology Act states that any transaction/contract relating to goods/class of goods or undertakings shall be as per the weight/measurement/numbers prescribed by the Metrology Act. The specifications with respect to the exact denomination of the weight of goods to be considered in transactions are contained in rules by each state.

#### **The Indian Boilers Act, 1923 (“Boilers Act”) and the Indian Boiler Regulations, 1950 (“Boilers Regulations”)**

The Boilers Act provides for *inter alia* the safety of life and property of persons from the danger of explosions of steam boilers and regulates the possession of steam boilers. It sets out the requirements for achieving uniformity in registration and inspection during operation and maintenance of boilers in India and provides for penalties for illegal use of boilers. The Boilers Regulations provide for *inter alia*, standard requirements with respect to material, construction, safety and testing of boilers.

#### **The Explosives Act, 1884 (the “Explosives Act”) and the Explosives Rules, 2008 (the “Explosive Rules”)**

The Explosives Act is a comprehensive law which regulates by licensing for the manufacturing possession, sale, transportation, export and import of explosives. As per the definition of ‘explosives’ under the Explosives Act, any substance, whether a single chemical compound or a mixture of substances, whether solid or liquid or gaseous, used or manufactured with a view to produce a practical effect by explosion or pyrotechnic effect shall fall under the Explosives Act. Extensive penalty provisions have been provided for manufacture, import or export, possession, usage, selling or transportation of explosives in contravention of the Explosives Act. In furtherance to the purpose of this Act, the Central Government has notified the Explosive Rules in order to regulate the manufacture, import, export, transport and possession for sale or use of explosives.

#### **Special Economic Zones Act, 2005 (“SEZ Act”) and the Special Economic Zone Rules, 2006 (“SEZ Rules”)**

A special economic zone (“**SEZ**”) is a specifically delineated duty free enclave, deemed to be a foreign territory for the purposes of trade as well as duties and tariffs. A board of approval has been set up under the SEZ Act, which is responsible for promoting the SEZ and ensuring its orderly development. The SEZ Rules prescribe the procedure for the operation and maintenance of a SEZ and for setting up and conducting business therein.

### Labour law legislations

#### **Factories Act, 1948**

The Factories Act provides for a healthy working environment for the workers/ labourers. The Factories Act regulates occupational safety, health and welfare of workers of the industries, in which 10 or more workers are employed on any day of the preceding 12 months and in which manufacturing process is carried on with the aid of power and any premises where there are at least 20 workers, even while there may not be an electrically aided manufacturing process being carried on.

This legislation is being enforced by the Government through officers appointed under the Factories Act i.e. Inspectors of Factories, Deputy Chief Inspectors etc. who work under the control of the Chief Inspector of Factories and overall control of the Labour Commissioner. The ambit of the Factories Act includes provisions as

to the approval of factory building plans before construction or extension, investigation of complaints, maintenance of registers and the submission of yearly and half-yearly returns.

In addition to the Factories Act, the employment of workers is regulated by a wide variety of generally applicable labour laws including, (i) Contract Labour (Regulation and Abolition) Act, 1970; (ii) Employees' Provident Funds and Miscellaneous Provisions Act, 1952; (iii) Employees' State Insurance Act, 1948; and (iv) The Trade Unions Act, 1926 and the Trade Union (Amendment) Act, 2001. Further, the Government of India has enacted the Code on Wages, 2019, the Occupational Safety, Health and Working Conditions Code, 2020, the Industrial Relations Code, 2020 and the Code on Social Security, 2020, each of which have received the assent of the President of India and will be brought into force on a date to be notified by the Central Government. Each of these codes propose to subsume various separate legislations currently governing employment of workers.

### **Environmental Laws**

We are subject to various environment regulations as the operation of our establishments might have an impact on the environment in which they are situated. The Environment (Protection) Act, 1986 was enacted with an objective of protection and improvement of the environment and for matters connected therewith. As per this Act, the Central Government has been given the power to take all such measures for the purpose of protecting and improving the quality of the environment and to prevent environmental pollution. Further, the Central Government has been given the power to give directions in writing to any person or officer or any authority for any of the purposes of the Act, including the power to direct the closure, prohibition or regulation of any industry, operation or process. The Environment (Protection) Rules, 1986, framed under the Environment Protection Act, 1986 lay down specific provisions regarding standards for emission or discharge of environmental pollutants, prohibition of carrying out industrial activities in certain geographical locations, procedures for function of environmental laboratories and submission of samples.

The Water (Prevention and Control of Pollution) Act, 1974 prohibits the use of any stream or well for the disposal of polluting matter, in violation of the standards set down by the State Pollution Control Board (“PCB”) and provides that the consent of the State PCB must be obtained prior to opening of any new outlets or discharges, which are likely to discharge sewage or effluent. The Air (Prevention and Control of Pollution) Act, 1981 requires that any individual, industry or institution responsible for emitting smoke or gases must apply in a prescribed form and obtain consent from the State PCB prior to establishing or operating any industrial plant in an air pollution control area.

Further, the Hazardous and Other Wastes (Management and Transboundary Movement) Rules, 2016 regulate the collection, reception, treatment and storage of hazardous waste. In terms of the Hazardous Waste Rules, occupiers, being persons who have control over the affairs of a factory or premises or any person in possession of hazardous or other waste, have been, *inter alia*, made responsible for safe and environmentally sound management of hazardous and other wastes generated in their establishments and are required to obtain license/ authorisation from the respective State PCB for handling, generation, collection, storage, packaging, transportation, usage, treatment, processing, recycling, recovery, pre-processing, co-processing, utilising, selling, transferring or disposing hazardous or other waste.

We are also subject to the fire control and safety rules and regulations framed by the specific state governments where we own, operate and maintain establishments. The legislations include provisions in relation to fire safety and life saving measures by occupiers of buildings, licensing provisions and penalties for non-compliance.

Further, the Ministry of Environment, Forest and Climate Change has issued Draft Environment Impact Assessment Notification 2020 (“EIA 2020”) which proposes to replace the erstwhile Environment Impact Assessment Notification, 2006. The EIA 2020 *inter alia* contemplates two kinds of approvals, being (i) prior environment clearance with the approval of expert committees and (ii) environmental permission or provision without the approval of expert committees. Certain projects including clay and sand extraction, digging well or foundations of buildings, solar thermal power plants and common effluent treatment plants have been exempted from such approvals.

### **Intellectual Property Laws**

Intellectual property rights refers to the general term for intangible, intellectual, industrial property rights through patents, copyrights and trademarks and includes geographical indications, trade secrets, and confidential information. These property rights allow the holder to exercise a monopoly on the use of the item for a specified period.

The Trade Marks Act, 1999, as amended (the “**Trade Marks Act**”), provides for the registration of trademarks in India, pursuant to which the registered owner of a trademark is granted exclusive rights to registered marks, including brands, labels and headings, and to obtain relief in case of infringement for commercial purposes.

The Patents Act, 1970, as amended (the “**Patents Act**”) governs the patent regime in India and provides for, amongst other things, patent protection period of 20 years from the date of filing the patent application and recognition of product and process patents.

### **Foreign Investment Regulations**

Foreign investment in India is governed by the provisions of Foreign Exchange Management Act, 1999, as amended, along with the rules, regulations and notifications made by the Reserve Bank of India thereunder, and the consolidated FDI Policy, effective from October 15, 2020, issued by the DPIIT, and any modifications thereto or substitutions thereof, issued from time to time (the “**Consolidated FDI Policy**”). Under the current Consolidated FDI Policy, foreign direct investment in companies engaged in the manufacturing sector is permitted up to 100% of the paid-up share capital of such company under the automatic route, i.e. without requiring prior government approval, subject to compliance with certain prescribed pricing guidelines and reporting requirements.

### **Foreign Trade Regulations**

Imports and exports are governed by the Foreign Trade (Development and Regulation) Act, 1992, as amended (the “**FTDR**”) and the Export and Import Policy (the “**EXIM Policy**”) formulated by the Central Government from time to time. FTDR provides for an Importer Exporter Code (“**IEC**”) to be granted to those persons licensed to carry out imports and exports, which may be suspended or cancelled in case of violation of the provisions of FTDR or the EXIM Policy. No person is allowed to carry out imports and exports without a valid IEC. Failure to mention IEC number attracts a penalty of not less than ₹ 10,000 and not more than five times the value of the goods or services or technology in respect of which any contravention is made or is attempted to be made, whichever is made.

### **Remission of Duties and Taxes on Exported Products (“**RoDTEP**”)**

Through a press release dated March 13, 2020, the Cabinet Committee on Economic Affairs approved the RoDTEP scheme for reimbursement of taxes, duties, or levies, at the Central, State and local level, which are currently not being refunded under any other mechanism, but which are incurred in the process of manufacture and distribution of exported products. This scheme has replaced the ongoing Merchandise Export from India Scheme (“**MEIS**”) introduced by the Foreign Trade Policy 2015-2020.

By way of notification bearing number 30/2015-2020 dated September 1, 2020, the Department of Commerce, Ministry of Commerce and Industry imposed a ceiling on the benefits under the MEIS available to exporters from September 1, 2020 and discontinued all benefits under the MEIS with effect from January 1, 2021. The detailed operational framework for the RoDTEP including the rates were notified by the Department of Commerce, Ministry of Commerce and Industry on August 17, 2021. The notified rates will apply to all products from January 1, 2021, irrespective of the date of the notification.

In addition to the above, our Company is subject to various laws and regulations such as the Petroleum Act, 1934, fire acts of various states, state laws under the Industrial Establishments (National and Festival Holidays) Act, 1965 and the provisions of the Companies Act 2013 and rules framed thereunder, and other applicable statutes imposed by the Government of India or the state governments and authorities for our day-to-day business and operations. Our Company is also amenable to various central tax laws including Central Goods and Service Tax Act, 2017, Central Sales Tax Act, 1956, Integrated Goods and Services Tax Act, 2017, Customs Act, 1961 and various state tax laws.



## HISTORY AND CERTAIN CORPORATE MATTERS

### Brief history of our Company

Our Company was incorporated as “Tega India Limited” under the Companies Act, 1956, as a public limited company, pursuant to a certificate of incorporation dated May 15, 1976, issued by the RoC. Our Company received a certificate of commencement of business on May 28, 1976, from the RoC. Pursuant to a special resolution passed by our Shareholders on January 4, 2002, and with the approval of the Central Government on January 31, 2002, the name of our Company was changed to “Tega Industries Limited”, and a fresh certificate of incorporation dated February 1, 2002, was issued by the RoC.

### Changes in Registered Office

Date of change	Details of change	Reasons for change
April 16, 2007	The registered office of our Company was changed from P-40, Block-B, New Alipore, Kolkata 700 053, West Bengal, India to 147, Block-G, New Alipore, Kolkata 700 053, West Bengal, India	For business convenience

### Our main objects

The main objects of our Company as contained in our Memorandum of Association are:

- “To carry on the business of manufacturing, buying, selling, exporting, importing designing, installing, servicing and dealing in all kinds of wear resistant components and moulded wear resistant products made of rubber, plastics, metals and its alloys, ceramic materials, ceramals or combinations of ceramic or metallic alloy composites, for use in industries and mineral mining of all description and for material handling and processing facilities at ports, dry docks, steel plants, thermal power stations, mines, cement, plants, smelter complexes, power stations, quarrying, crushing, beneficiation plants and any other uses.*
- To carry on business as manufacturers of and dealers in lining made of rubber, plastics, metals, and its alloys, ceramic materials, ceramals or combinations of ceramic or metal or metallic alloy composites for grinding mills, ball mills, impactors, washing drums, pumps, floatation cells, concrete mixers and other plant, machinery and equipment.*
- To carry on business as manufacturers of, and dealers in, wear components made of rubber, plastics, metals and its alloys, ceramic materials, ceramals, or combination of ceramic or metal or metallic alloy composites for wagon tippers, unloaders, bins, chutes launders, skips, truck bodies, granby cars, and other similar appliances.*
- To carry on business as manufacturers of and dealers in, screen decks made of rubber, plastics, metals and its alloys, ceramic materials, ceramals or combinations of ceramic or metal or metallic alloy composites, rubber, cloth, belt scrapers and moulded products made of rubber, plastics, metals and, its alloys, ceramic materials and ceramals or combinations of ceramic or metal or metallic alloy composites.*
- To carry on the business of designing and manufacturing grinding mills, ball mills, impactors, washing drums, pumps, flotations cells, vibrating feeders, concrete mixers, bins, chutes, launders, skips, truck bodies, granby cars and other plant and machinery and equipment for material handling conveying, processing and beneficiation.*
- To carry on the business of retreading of types of all kinds, and of manufacturing and dealing in seals, o-rings, back up rings, wiper rings, piston rod seals, vehicle tracks, sports ground and road surfaces and all kinds of moulded products, with or without reinforcement, pods for military tracked vehicles, ratabelt sleeves, rubber slings for loaders, gate seals, rubber hoses rubber lined parts for pumps, floatation equipments, rubber lined pipe fittings, containers, tanks for fluids, wheels, rolls, chlor cells, and similar other products and appliances which are capable of being dealt in or in connection with or for the benefit of the undertaking of the Company.*
- To carry on the business of making, processing and manufacturing rubber, rubber products of all kinds and articles made from rubber, styrene rubber, butadiene rubber, EP rubber, butyl rubber, chloroprene*

*rubber, nitrile rubber, cerbunan, silicone rubber flourene rubber, isoprene rubber and materials used in the manufacture and or treatment of natural and articles and dealing in the same.”*

The main objects clause as contained in the Memorandum of Association enable our Company to carry on the business presently being carried out and proposed to be carried out by it.

### Amendments to our Memorandum of Association

The following changes have been made to our Memorandum of Association in the last 10 years preceding the date of this Red Herring Prospectus:

Date of change/Shareholders' resolution	Nature of amendment
September 30, 2013	Clause VI of our Memorandum of Association was amended to reflect increase in the authorised share capital of our Company from ₹100,000,000 divided into 9,300,000 equity shares of ₹10 each and 700,000 preference shares of ₹10 each to ₹700,000,000 divided into 60,000,000 equity shares of ₹10 each and 10,000,000 preference shares of ₹ 10 each.
February 8, 2018	Clause VI of our Memorandum of Association was amended to reflect increase in the authorised share capital of our Company from ₹700,000,000, divided into 60,000,000 equity shares of ₹10 each, and 10,000,000 preference shares of ₹10 each to ₹1,050,000,000 divided into 70,000,000 equity shares of ₹ 10 each, and 35,000,000 preference shares of ₹ 10 each.
August 7, 2021	Alteration of the heading appearing in the MoA of our Company “ <i>THE COMPANIES ACT, 1956</i> ” by substituting with the following heading: “ <i>THE COMPANIES ACT, 2013</i> ” Alteration of Clause 3(B) of the MoA which read as “ <i>The objects incidental or ancillary to the attainment of the main objects are</i> ” to: “ <i>The objects necessary for the attainment of the above main objects are</i> ” along with addition of certain objects Deletion of Clause 4 of the MoA which read as “ <i>Other Objects of the Company</i> ”

### Major events in the history of our Company

The table below sets forth some of the major events in the history of our Company:

Calendar Year	Details
1975 - 76	Collaboration of our Promoter, Madan Mohan Mohanka with Skega AB, Sweden and incorporation of our Company.
1991	Joint Venture alliance with Hosch (G.B.) Ltd.
1992	Application for registration of our patent in relation to method of preparing liner.
2001	Buyout by Madan Mohan Mohanka of Skega AB's entire stake in our Company.
2002	Amalgamation of MM Global Private Limited with our Company
2006	Acquired Beruc Equipment, South Africa
2010	Grant of patent in relation to improved screen panel.
2010-11	Acquired Acotec S.A, Chile and Losugen Pty Ltd, Australia
2011	Investment by Wagner Limited, an affiliate of TA Associates Management, L.P.
2013	Grant of patent in relation to mosaic liners for chutes.
2018	Amalgamation of Tega Industries (SEZ) Limited with our Company.
2019	Grant of trademark in relation to 'DynaPrime'.

### Awards, Accreditations and Recognitions

Fiscal	Details
2008	Madan Mohan Mohanka was recognized by the Indian Institute of Mineral Engineers, Trivandrum, for his eminence and outstanding contribution to the profession of mineral engineering.
2011	Madan Mohan Mohanka was awarded the 'Outstanding Entrepreneurship Award at the Asia Pacific Entrepreneurship Awards, 2011.
2011	Madan Mohan Mohanka was presented with the 'Distinguished alumnus award' by the Indian Institute of Management, Ahmedabad.
2011-12	Madan Mohan Mohanka was conferred the award of excellence for his contributions to society and achievement in the field of his vocation by the Rotary Club of Calcutta Metropolitan, R.I District 3291.

<b>Fiscal</b>	<b>Details</b>
2012	Madan Mohan Mohanka was the finalist in the Ernst & Young Entrepreneur of the Year, 2012, India.
2013	Awarded the ‘Best Existing Large Corporate with turnover between Rs. 300 – 1000 crore’ at the Economic Times Bengal Corporate Award, 2013.
2015	Granted the Quality Management System ISO 9001:2015 accreditation to Tega Africa.
2018	Our Company was granted the Quality Certification, SA 8000:2014 accreditation for our manufacturing facility located in Samali, West Bengal.
2019	Our Company was granted the Quality Certifications ISO 9001:2015, ISO 14001:2015 and ISO 45001:2018 accreditation.

#### **Time/cost overrun**

As on the date of this Red Herring Prospectus, there have been no time/cost overruns in setting up our projects.

#### **Defaults, rescheduling or restructuring of borrowings with financial institutions/banks**

As on the date of this Red Herring Prospectus, there has been no default, rescheduling or restructuring of borrowings with financial institutions or banks.

#### **Significant strategic and financial partnerships**

As on the date of this Red Herring Prospectus, our Company does not have any significant strategic or financial partners.

#### **Details regarding material acquisitions or divestments of business/undertakings, mergers, amalgamation, revaluation of assets, etc. in the last 10 years**

Except as disclosed below, our Company has not made any material acquisitions or divestments of any business or undertakings, mergers, amalgamation or revaluation of assets in the last 10 years preceding the date of this Red Herring Prospectus.

#### ***Scheme of Amalgamation of Tega Industries (SEZ) Limited (“Tega SEZ”) with our Company***

Pursuant to orders dated November 3, 2017 and February 8, 2018, the National Company Law Tribunal, Ahmedabad and the National Company Law Tribunal, Kolkata, respectively, sanctioned a scheme of amalgamation under Sections 230 to 232 of the Companies Act, 2013 pursuant to which Tega SEZ, a wholly owned subsidiary of our Company, was amalgamated into our Company (“**Scheme of Amalgamation**”). The appointed date of the Scheme of Amalgamation was October 1, 2016 and the effective date was April 16, 2018. The Scheme of Amalgamation was entered into with the aim of achieving synergic advantages such as greater financial strength and flexibility, better and efficient management, operational efficiencies, cost competitiveness, simplified corporate structure etc. to attain higher shareholders’ value.

Further, pursuant to the Scheme of Amalgamation, the entire undertaking of Tega SEZ including all its assets, properties, entitlement, rights, benefits and advantages, liabilities and obligations were transferred to and vested in our Company as a going concern. Further, pending legal proceedings by or against Tega SEZ were required to be continued by or against our Company. The authorized share capital of our Company was increased by the extent of the authorized share capital of Tega SEZ and accordingly, our Memorandum of Association was automatically amended. No new shares were issues pursuant to such Scheme of Amalgamation.

#### **Shareholders’ Agreements and Other Agreements**

##### ***Share Subscription and Shareholders’ agreements***

***Share Subscription and Purchase Agreement dated April 29, 2011 entered into by and among our Company, Wagner Limited (the “Investor”), Madan Mohan Mohanka, Manish Mohanka, Mehul Mohanka, Madan Mohan Mohanka (HUF), Mehul Mohanka (HUF), NFSPL, Marudhar Food & Credit Limited (“Erstwhile Promoters”, together with the Company and Investor, the “Parties”), read with the amendment agreements dated September 3, 2018 and July 10, 2020 and August 2, 2021 (with effect from March 9, 2021) and Shareholders’ Agreement dated April 29, 2011 entered into by and among our Company, the Investor and the Erstwhile Promoters read with the amendment agreements dated September 3, 2018 and July 10, 2020, August 2, 2021 (with effect from March 9, 2021) entered into by and among the Parties and the amendment agreement dated August 7, 2021 entered into by and among our Company, our Promoters and the Investor.***

In terms of the SSPA, the Investor purchased and subscribed to 76,893 Equity Shares for an aggregate consideration of ₹150.00 million and 668,637 CCPP (“**Investor CCPP**”) for an aggregate consideration of ₹1500 million. Pursuant to such purchase and subscription of shares of our Company, the Investor acquired 14.54% of the issued and paid-up share capital of our Company, on a fully diluted basis, in the year 2011. Consequently, the SHA was entered into by and among our Company, the Investor and our Promoters.

In terms of the SHA, the Investor, has a right to nominate one director on our Board. Further, the Investor has also been provided with certain key rights such as right to appoint observers including additional observers, right of first offer and certain tag-along rights, pre-emptive rights, anti-dilution adjustments, rights in relation to reserved matters, information rights and other such additional rights in accordance with the terms of the SHA. Additionally, the Investor can cause our Company to buy-back the put options held by the Investor if an initial public offering by our Company is not completed within the prescribed period, in accordance with the terms of the SHA. Further, under the SHA the Investor CCPP shall be automatically converted in to an equal number of Equity Shares on the happening of certain events, including the filing of a red herring prospectus for an initial public offering by our Company or on a particular date, as mutually agreed between our Company, the Investor and our Promoters.

Pursuant to the SHA Amendment Agreement, certain rights of our Company, Wagner Limited and our Promoters (collectively, referred to as “**Parties**” and individually, referred to as “**Party**”), among others, in relation to nomination of directors to our Board, transfer of securities and restricted transfers between the Parties, as stipulated in the SHA, have been amended or waived till the allotment of Equity Shares pursuant to the Offer. In terms of the SHA Amendment Agreement, the Investor has consented to certain actions required to be taken by our Company in relation to the Offer as required under the SHA. Further, in terms of the SHA Amendment Agreement, SHA shall automatically stand terminated upon the date of allotment of Equity Shares pursuant to the Offer and accordingly, the special rights therein shall also automatically stand terminated upon the date of allotment of Equity Shares pursuant to the Offer. Further, in case listing is not completed by the date contemplated in the SHA Amendment Agreement, the provisions of the SHA Amendment Agreement shall automatically stand terminated without any further act or deed required on the part of any Party and the rights available to the Investors under the SHA, including among others, differential voting rights and certain exit and secondary sale rights will be reinstated upon such termination of the SHA Amendment Agreement.

#### ***Joint venture agreement***

***Joint venture agreement dated November 12, 1991 between Hosch (G.B.) Limited, England (“Hosch England”) (“JVA”) and Madan Mohan Mohanka read with the Share purchase agreement dated May 29, 2010 between Madan Mohan Mohanka and Company (“SPA, and together with the JVA, the “Hosch JVA”)***

Pursuant to the JVA, Hosch India was incorporated in India on July 10, 1991, as a private limited company under the Companies Act, 1956 for the purpose of manufacturing and marketing of belt scrapper and allied systems. In terms of the JVA, amongst other things, Hosch England shall assist in making available the requisite know-how to Hosch India covering aspects such as planning, layout, overseas marketing, R&D and procurement of raw materials. Further, in accordance with the JVA, our Joint Venture and Hosch England have entered into the Foreign Collaboration Agreement dated November 12, 1991 wherein Hosch England was required to provide technical information and other related services to Hosch India including training of staff etc. for a prescribed period of time.

Subsequently, Madan Mohan Mohanka transferred 112,500 equity shares, being the entire stake in our Joint Venture held by him, to our Company in accordance with the SPA for an aggregate consideration of ₹150.07 million.

#### **Other agreements**

Our Company has not entered into any other subsisting material agreement, including with strategic partners, joint venture partners or financial partners, other than in the ordinary course of business.

#### **Holding Company of our Company**

As on date of this Red Herring Prospectus, NFSPL is the holding company of our Company. For details, see “**Promoter and Promoter Group - Details of our corporate Promoter**” on page 200.

#### **Subsidiaries of our Company**

As on the date of this Red Herring Prospectus, our Company has 13 foreign subsidiaries, as set forth below:

## **1. Tega Africa**

### *Corporate Information*

Tega Africa (formerly, Beruc Equipment (Proprietary) Limited) was incorporated on November 8, 1984, and is governed under the laws of South Africa. Our Company acquired Tega Africa in accordance with the share purchase agreement dated May 12, 2006. The registered office of Tega Africa is located at 2 Uranium Road, Vulcania, Brakpan, Gauteng, 1541.

### *Nature of Business*

The principle business of Tega Africa is, amongst others, engaging in the business of designing, manufacturing and supplying of abrasion and wear resistant products and services required for mining, mineral processing and bulk material handling industries.

### *Capital Structure and shareholding*

As on the date of this Red Herring Prospectus, the authorized share capital of Tega Africa is ZAR 4,000, divided into 4,000 ordinary shares of ZAR 1 each.

The issued, subscribed and paid-up capital of Tega Africa is ZAR 100 divided into 100 ordinary shares of ZAR 1 each. Our Company through its subsidiary, Tega Investments South Africa Pty. Ltd, indirectly holds the entire shareholding of Tega Africa.

### *Accumulated profits or losses not accounted for by our Company*

As on the date of this Red Herring Prospectus, there are no accumulated profits or losses of Tega Africa not accounted for by our Company.

## **2. Tega Chile**

### *Corporate Information*

Tega Chile (formerly, Acotec SA) was incorporated on February 5, 1990, and is governed under the laws of Chile. Our Company acquired Tega Chile in accordance with the stock purchase agreement dated February 3, 2011. The registered office of Tega Chile is located at Av. Galvarino 7701, Quilicura, Santiago de Chile.

### *Nature of Business*

The principle business of Tega Chile is, amongst others, engaging in the business of designing and manufacturing of liners and wear component for the mining companies.

### *Capital Structure and shareholding*

The issued, subscribed and paid-up capital of Tega Chile is CLP 5,154,821,382 divided into 38,727 equity shares of no face value each and CLP 18,907,644,818 divided into 217,218 preference shares of no face value each. Our Company through its subsidiary, Tega Holdings Pte, holds the entire equity shareholding, amounting to 21.42%, and the entire preference shareholding, amounting to 78.58%, thereby indirectly holding the entire shareholding of Tega Chile.

### *Accumulated profits or losses not accounted for by our Company*

As on the date of this Red Herring Prospectus, there are no accumulated profits or losses of Tega Chile not accounted for by our Company.

## **3. Losugen**

### *Corporate Information*

Losugen was incorporated on July 26, 2001 and is governed under the laws of Australia. Our Company acquired Losugen in accordance with the share purchase agreement dated December 21, 2010 read with the amendment agreement to the share purchase agreement dated January 25, 2011. The registered office of Losugen is located at KPMG Enterprise, Level 8, 235, St. George's terrace, Perth, WA 6000, Australia.

### *Nature of Business*

The principle business of Losugen is, amongst others, engaging in the business of supplying of specialized abrasion and wear-resistant products used in mineral beneficiation, mining and bulk solids handling industry.

### *Capital Structure and shareholding*

The issued, subscribed and paid-up capital of Losugen is AUD 2 divided into 2 equity shares of no face value each. Our Company through its subsidiary, Tega Holdings, indirectly holds the entire shareholding of Losugen.

### *Accumulated profits or losses not accounted for by our Company*

As on the date of this Red Herring Prospectus, there are no accumulated profits or losses of Losugen not accounted for by our Company.

## **4. Tega Industries Inc.**

### *Corporate Information*

Tega Industries Inc. was incorporated on November 27, 2001, under laws of the State of Delaware. The registered office of Tega Industries Inc. is located at 7100 N Camino Martin # 100, Tucson, AZ 85741, USA.

### *Nature of Business*

The principle business of Tega Industries Inc. is, amongst others, engaging in the business of distribution and sale of wear resistant rubber products to the mining and mineral processing and material handling industries under the laws of the State of Delaware.

### *Capital Structure and shareholding*

As on the date of this Red Herring Prospectus, the authorized share capital of Tega Industries Inc. is USD 500,000, divided into 5,000 equity shares of USD 100 each.

The issued, subscribed and paid-up capital of Tega Industries Inc. is USD 200,000 divided into 2,000 equity shares of USD 100 each. Our Company holds the entire shareholding of Tega Industries Inc.

### *Accumulated profits or losses not accounted for by our Company*

As on the date of this Red Herring Prospectus, there are no accumulated profits or losses of Tega Industries

## **5. Tega Holdings Pty. Ltd (“Tega Holdings”)**

### *Corporate Information*

Tega Holdings was incorporated on December 3, 2010, and is governed under the laws of Australia. The registered office of Tega Holdings is Unit 6, 57, Kent street, Cannington, WA, 6107, Australia.

### *Nature of Business*

The principle business of Tega Holdings is, amongst others, engaging in the business of financing and investing in the inter-company requirement only.

### *Capital Structure and shareholding*

The issued, subscribed and paid-up capital of Tega Holdings is AUD 5,000 divided into 5,000 equity shares of no face value each. Our Company through its subsidiary, Tega Holdings Pte, indirectly holds the entire shareholding of Tega Holdings.

### *Accumulated profits or losses not accounted for by our Company*

As on the date of this Red Herring Prospectus, there are no accumulated profits or losses of Tega Holdings not accounted for by our Company.

## **6. Tega Industries Canada Inc. (“Tega Canada”)**

### *Corporate Information*

Tega Canada was incorporated on August 27, 2007, and is governed under the laws of Canada. The registered office of Tega Canada is located at Unit 1, 1305, Kelly Lake Road, Sudbury, Ontario P3E 5P5.

### *Nature of Business*

The principle business of Tega Canada is, amongst others, engaging in the business of sale of mill liners, screen media, conveyor accessories and accessories.

### *Capital Structure and shareholding*

As on the date of this Red Herring Prospectus, the authorized share capital of Tega Canada is unlimited.

The issued, subscribed and paid-up capital of Tega Canada is CAD 50,000 divided into 50,000 equity shares of CAD 1 each. Our Company holds the entire shareholding of Tega Canada.

### *Accumulated profits or losses not accounted for by our Company*

As on the date of this Red Herring Prospectus, there are no accumulated profits or losses of Tega Canada not accounted for by our Company.

## **7. Tega Investments Ltd.**

### *Corporate Information*

Tega Investments Ltd. was incorporated on May 2, 2006, and is governed under the laws of Bahamas. The registered office of Tega Investments Ltd. is located at British American Insurance House, Second Floor, Marlborough Street, P.O Box CB-12399, Nassau, Bahamas.

### *Nature of Business*

The principle business of Tega Investments Ltd. is, amongst others, engaging in the business of investment within the inter-company and the group company of the Company.

### *Capital Structure and shareholding*

As on the date of this Red Herring Prospectus, the authorized share capital of Tega Investments Ltd. is USD 50,000 divided into 50,000 equity shares of USD 1 each.

The issued, subscribed and paid-up capital of Tega Investments Ltd. is USD 50,000 divided into 50,000 equity shares of USD 1 each. Our Company holds the entire shareholding of Tega Investments Ltd.

### *Accumulated profits or losses not accounted for by our Company*

As on the date of this Red Herring Prospectus, there are no accumulated profits or losses of Tega Investments Ltd. not accounted for by our Company.

## **8. Tega Investments South Africa Pty. Ltd (“Tega Investments Africa”)**

### *Corporate Information*

Tega Investments Africa was incorporated on April 19, 2006, and is governed under the laws of South Africa. The registered office of Tega Investments Africa is located at 2 Uranium Road, Vulcania, Brakpan, Gauteng, 1554, P.O. Box 268, Florida Hills, 1716.

### *Nature of Business*

The principle business of Tega Investments Africa is, amongst others, engaging in the business of investing and financing within the Tega group of Companies.

### *Capital Structure and shareholding*

As on the date of this Red Herring Prospectus, the authorized share capital of Tega Investments Africa is ZAR 1,000, divided into 1,000 ordinary shares of ZAR 1 each.

The issued, subscribed and paid-up capital of Tega Investments Africa is ZAR 400 divided into 400 ordinary shares of ZAR 1 each. Our Company through its subsidiary, Tega Holdings Pte, indirectly holds the entire shareholding of Tega Investments Africa.

### *Accumulated profits or losses not accounted for by our Company*

As on the date of this Red Herring Prospectus, there are no accumulated profits or losses of Tega Investments Africa not accounted for by our Company.

## **9. Tega Do Brasil Servicos Technicos Ltda (“Tega Brasil”)**

### *Corporate Information*

Tega Brasil was incorporated on April 4, 2008, and is governed under the laws of Brazil. The registered office of Tega Brasil is located at Avenida Eldes Scherrer Souza- No. 975 SL 1221, Parque Residencial Laranjeiras, Serra, Espírito Santo, Brasil, CEP/ZIP 29165-680.

### *Nature of Business*

The principle business of Tega Brasil is, amongst others, engaging in the business of marketing and supplying the product required for mining, mineral processing and bulk handling.

### *Capital Structure and shareholding*

As on the date of this Red Herring Prospectus, the authorized share capital of Tega Brasil is R\$ 500,000, divided into 500,000 equity shares of R\$ 1 each.

The issued, subscribed and paid up share capital of Tega Brasil is R\$ 450,547 divided into 450,547 equity shares of R\$ 1 each. Our Company, including through its nominee, holds the entire shareholding of Tega Brasil.

### *Accumulated profits or losses not accounted for by our Company*

As on the date of this Red Herring Prospectus, there are no accumulated profits or losses of Tega Brasil not accounted for by our Company.

## **10. Tega Holdings Pte Ltd (“Tega Holdings Pte”)**

### *Corporate Information*

Tega Holdings Pte was incorporated on December 1, 2010, and is governed under the laws of Singapore. The registered office of Tega Holdings Pte, is located at 9 Tamasek Boulevard #26-02A Suntec Tower Two, Singapore (038989).

### *Nature of business*

The principle business of Tega Holdings Pte, is, amongst others, engaging in the business of investing and wholesale trade of variety of goods required for the use in mining and mineral and material handling industries.

### *Capital Structure and shareholding*

The issued, subscribed and paid-up capital of Tega Holdings Pte, is SGD 12,350 divided into 12,350 ordinary shares of no face value each, and USD 59,250,000, divided into 592,500 preference shares of no face value each. Our Company holds the entire shareholding of Tega Holdings Pte.

### *Accumulated profits or losses not accounted for by our Company*

As on the date of this Red Herring Prospectus, there are no accumulated profits or losses of Tega Holdings Pte not accounted for by our Company.



**11. Tega Industries Australia Pty. Ltd. (“Tega Australia”)**

*Corporate Information*

Tega Australia, was incorporated on June 11, 2002 and is governed under the laws of Australia. The registered office of Tega Australia, is located at Unit 6, 57 Kent Street, Cannington, WA, 6107.

*Nature of business*

The principle business of Tega Australia, is, amongst others, engaging in the business of supplying of specialized abrasion and wear-resistant products used in mineral beneficiation, mining and bulk solids handling industry.

*Capital Structure and shareholding*

The issued, subscribed and paid-up capital of Tega Australia is AUD 85,000 divided into 85,000 equity shares of no face value each. Our Company holds the entire shareholding of Tega Australia.

*Accumulated profits or losses not accounted for by our Company*

As on the date of this Red Herring Prospectus, there are no accumulated profits or losses of Tega Australia, not accounted for by our Company.

**12. Edoctum S.A (“Edoctum”)**

*Corporate Information*

Edoctum was incorporated on June 1, 2007 and is governed under the laws of Chile. The registered office of Edoctum is located at Rosario Sur 91, Las Condes, Santiago de Chile.

*Nature of Business*

The principle business of Edoctum is, amongst others, engaging in the business of organizing and realizing business of technical events, courses, seminars and Congres.

*Capital Structure and shareholding*

The issued, subscribed and paid-up capital of Edoctum is CLP 6,247,142 divided into 900 ordinary shares of no face value each. Our Company through its subsidiaries, Tega Chile and Tega Holdings Pte, holds 99.89% and 0.11% of the shareholding of Edoctum respectively, thereby indirectly holding the entire shareholding of Edoctum.

*Accumulated profits or losses not accounted for by our Company*

As on the date of this Red Herring Prospectus, there are no accumulated profits or losses of Edoctum not accounted for by our Company.

**13. Edoctum Peru S.A (“Edoctum Peru”)**

*Corporate Information*

Edoctum Peru was incorporated on March 22, 2012 and is governed under the laws of Peru. The registered office of Edoctum Peru, is located at Calle los manzanos 691, San Isidro, Lima, Peru .

*Nature of Business*

The principle business of Edoctum Peru, is, amongst others, engaging in the business of organising and realizing business of technical events, courses, Seminars and Congres.

*Capital Structure and shareholding*

As on the date of this Red Herring Prospectus, the authorized share capital of Edoctum Peru is PEN 1,000, divided into 1,000 equity shares of PEN 1 each.

The issued, subscribed and paid-up capital of Edoctum Peru is PEN 1,000 divided into 1,000 equity shares of PEN 1 each. Our Company through its subsidiaries, Edoctum and Tega Chile, holds 99.99% and 0.01% of the shareholding of Edoctum Peru respectively, thereby indirectly holding the entire shareholding of Edoctum Peru.

*Accumulated profits or losses not accounted for by our Company*

As on the date of this Red Herring Prospectus, there are no accumulated profits or losses of Edoctum Peru, not accounted for by our Company.

**Joint Venture**

As on the date of this Red Herring Prospectus, our Company has a joint venture, namely Hosch India.

*Corporate Information*

Hosch India was incorporated as “Hosch Equipment (India) Pvt. Limited” on July 10, 1991, as a private limited company under the Companies Act, 1956, pursuant to a certificate of incorporation, issued by the RoC. Hosch India is registered as a “small enterprise” by the Ministry of Micro, Small and Medium Enterprises. Pursuant to the conversion of Hosch India to a public limited company, and as approved by the Shareholders pursuant to a resolution dated March 15, 2010, the name of Hosch India was changed to “Hosch Equipment (India) Limited”, and the RoC issued a fresh certificate of incorporation dated July 16, 2010. The registered office of Hosch India is located at 807, Godrej Waterside, Tower II, 8<sup>th</sup> Floor, Plot No. 5, Block DP, Salt Lake Electronics Complex, Sector V, Kolkata 700 091, West Bengal.

*Nature of Business*

The principle business of Hosch India is, amongst others, engaging in the business of conveyor components including belt scrappers and accessories.

*Capital Structure and shareholding*

As on the date of this Red Herring Prospectus, the authorized share capital of Hosch India is ₹2,500,000, divided into 250,000 equity shares of ₹10 each.

The issued, subscribed and paid-up capital of Hosch India Limited is ₹2,250,000 divided into 225,000 equity shares of ₹10 each. Our Company, including through its nominees, holds 50% of the entire shareholding of Hosch India.

*Accumulated profits or losses not accounted for by our Company*

As on the date of this Red Herring Prospectus, there are no accumulated profits or losses of Hosch India, not accounted for by our Company.

**Agreements with Key Managerial Personnel, Director or any other employee**

There are no agreements entered into by our Key Managerial Personnel or Director or Promoter or any other employee of our Company, either by themselves or on behalf of any other person, with any shareholder or any other third party with regard to compensation or profit sharing in connection with dealings in the securities of our Company.

**Guarantees given by our Promoter Selling Shareholders**

Our Promoter Selling Shareholders have not given any guarantee to any third parties as on the date of this Red Herring Prospectus.

## OUR MANAGEMENT

Under the Articles of Association, our Company is authorised to have a minimum of three directors and a maximum of up to 12 Directors. As on the date of this Red Herring Prospectus, our Company has seven Directors, comprising three Executive Directors and four Non-Executive Director, all of which are Independent Directors. Additionally, out of the four Independent Directors one is an independent woman director. The Chairman of our Board, Madan Mohan Mohanka, is an Executive Director. The present composition of our Board and its committees is in accordance with the corporate governance requirements provided under the Companies Act 2013 and the SEBI Listing Regulations.

The following table sets forth details regarding our Board as on the date of this Red Herring Prospectus:

Name, designation, address, occupation, date of birth, nationality, term, period of directorship and DIN	Age (in years)	Directorships in other companies
<p><b>Madan Mohan Mohanka</b></p> <p><i>Designation:</i> Chairman and Executive Director</p> <p><i>Address:</i> 146, Block – G, New Alipore, Kolkata – 700 053, West Bengal, India</p> <p><i>Occupation:</i> Business</p> <p><i>Date of birth:</i> August 13, 1943</p> <p><i>Nationality:</i> Indian</p> <p><i>Term:</i> Five years with effect from March 1, 2017 (Liable to retire by rotation)</p> <p><i>Period of Directorship:</i> Since the incorporation of our Company</p> <p><i>DIN:</i> 00049388</p>	78	<p><i>Indian Companies</i></p> <ul style="list-style-type: none"> <li>• Hosch Equipment (India) Limited</li> <li>• Maple Orgtech (India) Limited</li> <li>• Marudhar Food &amp; Credit Limited</li> <li>• MM Aqua Technologies Limited</li> <li>• M M Group Holdings Private Limited</li> <li>• MM Rosewood Buildinfra Private Limited</li> <li>• Nihal Fiscal Services Private Limited</li> <li>• Tega Parks &amp; Resorts Private Limited</li> <li>• TPW Engineering Limited</li> <li>• Trafalgar Consulting International Company Private Limited</li> </ul> <p><i>Foreign Companies</i></p> <ul style="list-style-type: none"> <li>• Losugen</li> <li>• Tega Africa</li> <li>• Tega Chile</li> <li>• Tega Do Brasil Servicos Technicos Ltda.</li> <li>• Tega Holdings Pte. Ltd.</li> <li>• Tega Holdings Pty. Ltd.</li> <li>• Tega Industries Australia Pty Ltd.</li> <li>• Tega Industries Inc.</li> <li>• Tega Industries Canada Inc,</li> <li>• Tega Investment South Africa (Pty) Ltd.</li> <li>• Tega Investment Limited</li> </ul>
<p><b>Mehul Mohanka</b></p> <p><i>Designation:</i> Managing Director and Group CEO</p> <p><i>Address:</i> 146, Block – G, New Alipore, Kolkata – 700 053, West Bengal, India</p> <p><i>Occupation:</i> Business</p> <p><i>Date of birth:</i> February 3, 1975</p> <p><i>Nationality:</i> Indian</p> <p><i>Term:</i> Five years with effect from April 12, 2018</p> <p><i>Period of Directorship:</i> Since June 6, 2002</p> <p><i>DIN:</i> 00052134</p>	46	<p><i>Indian Companies</i></p> <ul style="list-style-type: none"> <li>• Maple Orgtech (India) Limited</li> <li>• Marudhar Food &amp; Credit Limited</li> <li>• MM Aqua Technologies Limited</li> <li>• M M Group Holdings Private Limited</li> <li>• MM Rosewood Buildinfra Private Limited</li> <li>• Nihal Fiscal Services Private Limited</li> <li>• Tega Parks &amp; Resorts Private Limited</li> <li>• Trafalgar Consulting International Company Private Limited</li> <li>• West Bengal Industrial Development Corporation Limited</li> </ul> <p><i>Foreign Companies</i></p> <ul style="list-style-type: none"> <li>• Losugen</li> <li>• Tega Chile</li> <li>• Tega Do Brasil Servicos Technicos Ltda.</li> <li>• Tega Holdings Pte. Ltd.</li> </ul>

Name, designation, address, occupation, date of birth, nationality, term, period of directorship and DIN	Age (in years)	Directorships in other companies
<p><b>Syed Yaver Imam*</b></p> <p><i>Designation:</i> Executive Director</p> <p><i>Address:</i> 9, Sambhu Babu Lane, Merlin Regent, 3<sup>rd</sup> floor, FL-3C, Entally, Kolkata – 700 014, West Bengal, India</p> <p><i>Occupation:</i> Service</p> <p><i>Date of birth:</i> May 19, 1959</p> <p><i>Nationality:</i> Indian</p> <p><i>Term:</i> Liable to retire by rotation</p> <p><i>Period of Directorship:</i> Since July 19, 2005</p> <p><i>DIN:</i> 00588381</p>	62	<ul style="list-style-type: none"> <li>• Tega Holdings Pty. Ltd.</li> <li>• Tega Africa</li> <li>• Tega Industries Australia Pty Ltd.</li> <li>• Tega Industries Inc.</li> <li>• Tega Industries Canada Inc.</li> <li>• Tega Investment South Africa (Pty) Ltd</li> <li>• Tega Investment Limited</li> </ul> <hr/> <p><i>Indian Companies</i></p> <ul style="list-style-type: none"> <li>• Hosch Equipment (India) Limited</li> </ul> <p><i>Foreign Companies</i></p> <ul style="list-style-type: none"> <li>• Tega Africa</li> <li>• Tega Industries Australia Pty Ltd.</li> <li>• Tega Chile</li> <li>• Tega Investment South Africa (Pty.) Ltd</li> </ul>
<p><b>Hemant Madhusudan Nerurkar</b></p> <p><i>Designation:</i> Independent Director</p> <p><i>Address:</i> 1201, Lodha Grandeur, Rahimatullah Sayanti Road, Prabhadevi, Mumbai – 400 025, Maharashtra, India</p> <p><i>Occupation:</i> Director</p> <p><i>Date of birth:</i> October 20, 1948</p> <p><i>Nationality:</i> Indian</p> <p><i>Term:</i> Two years with effect from April 1, 2020</p> <p><i>Period of Directorship:</i> Since April 1, 2014</p> <p><i>DIN:</i> 00265887</p>	73	<p><i>Indian Companies</i></p> <ul style="list-style-type: none"> <li>• Adani Airport Holdings Limited</li> <li>• Adani Enterprises Limited</li> <li>• Crompton Greaves Consumer Electricals Limited</li> <li>• DFM Foods Limited</li> <li>• Igarashi Motors India Limited</li> <li>• NCC Limited</li> <li>• Skill Council for Mining Sector</li> <li>• Management and Entrepreneurship Professional Skills Council</li> <li>• Trust Asset Management Private Limited</li> <li>• TRL Krosaki Refractories Limited</li> </ul> <p><i>Foreign Companies</i></p> <ul style="list-style-type: none"> <li>• Tega Chile</li> <li>• TRL Krosaki China Limited</li> </ul>
<p><b>Jagdishwar Prasad Sinha</b></p> <p><i>Designation:</i> Independent Director</p> <p><i>Address:</i> A4-263, Sobha Onyx, Near Agara Junction, Sarjapur Road, Bangalore – 560 102, Karnataka, India</p> <p><i>Occupation:</i> Professional</p> <p><i>Date of birth:</i> December 29, 1962</p> <p><i>Nationality:</i> Indian</p> <p><i>Term:</i> Five years with effect from May 1, 2021<sup>#</sup></p> <p><i>Period of Directorship:</i> Since May 1, 2021<sup>#</sup></p> <p><i>DIN:</i> 02345086</p>	58	<p><i>Indian Companies</i></p> <ul style="list-style-type: none"> <li>• Nil</li> </ul> <p><i>Foreign Companies</i></p> <ul style="list-style-type: none"> <li>• Nil</li> </ul>

Name, designation, address, occupation, date of birth, nationality, term, period of directorship and DIN	Age (in years)	Directorships in other companies
<p><b>Madhu Dubhashi</b></p> <p><i>Designation:</i> Independent Director</p> <p><i>Address:</i> B29, Gate No. 3, Abhimanshree Society, NCL Pashan Road, Pune 411 008, Maharashtra, India</p> <p><i>Occupation:</i> Retired</p> <p><i>Date of birth:</i> February 6, 1951</p> <p><i>Nationality:</i> Indian</p> <p><i>Term:</i> Two years with effect from May 1, 2021<sup>#</sup></p> <p><i>Period of Directorship:</i> Since May 1, 2021<sup>#</sup></p> <p><i>DIN:</i> 00036846</p>	70	<p><i>Indian Companies</i></p> <ul style="list-style-type: none"> <li>• Axis Finance Limited</li> <li>• Clean Science and Technology Limited</li> <li>• JM Financial Trustee Company Private Limited</li> <li>• Pudumjee Paper Products Limited</li> <li>• Recommender Labs Private Limited</li> <li>• Sanghvi Movers Limited</li> </ul> <p><i>Foreign Companies</i></p> <ul style="list-style-type: none"> <li>• Nil</li> </ul>
<p><b>Rudolph Michael Edge</b></p> <p><i>Designation:</i> Independent Director</p> <p><i>Address:</i> Crystal Cove, Flat 11, 59 Satyadev Avenue, MRC Nagar, Chennai – 600 028, Tamil Nadu, India</p> <p><i>Occupation:</i> Retired company executive</p> <p><i>Date of birth:</i> October 10, 1946</p> <p><i>Nationality:</i> Indian</p> <p><i>Term:</i> Two years with effect from April 1, 2020</p> <p><i>Period of Directorship:</i> Since March 27, 2014</p> <p><i>DIN:</i> 00626151</p>	75	<p><i>Indian Companies</i></p> <ul style="list-style-type: none"> <li>• Fives CAIL-KCP Limited</li> <li>• Fuller Floate Edge Engineering OPC Private Limited</li> </ul> <p><i>Foreign Companies</i></p> <ul style="list-style-type: none"> <li>• Edge Impex Pty. Ltd.</li> </ul>

<sup>\*</sup>Syed Yaver Imam, who was designated as an Executive Director for the period from July 19, 2005 to May 31, 2019 and is currently an Executive Director on our Board, has in the past been designated as a Non-executive director on our Board from June 1, 2019 to March 31, 2021. Our Board has redesignated him as an Executive Director with effect from April 1, 2021, in accordance with applicable law.

<sup>#</sup>Appointed through a resolution passed by our Board on April 30, 2021 and regularized pursuant to a resolution passed by our Shareholders on August 7, 2021

### Brief profiles of our Directors

**Madan Mohan Mohanka** is one of the Promoters of our Company, and the Chairman and Executive Director of our Company. He holds a bachelor's degree in science (engineering) from Ranchi University and a post graduate diploma in business administration from Indian Institute of Management, Ahmedabad. He has been associated with our Company since its incorporation.

**Mehul Mohanka** is one of the Promoters of our Company, and the Managing Director and Group CEO of our Company. He holds a bachelor's degree in commerce from University of Calcutta. He also holds a master's degree in business administration from the University of Pittsburgh. Further, he has completed an advanced management program from Harvard Business School. He has been associated with the Indian Chamber of Commerce as a vice president. He is associated with the mining and construction equipment division of Confederation of Indian Industry as the chairman and is the co-chair of the national committee on mining of the Confederation of Indian Industry. He was also the chairman of the West Bengal State Council of the Confederation of Indian Industry. He has been associated with our Company since almost two decades and has been instrumental in diverse functions of our Company, such as sales and operations.

**Syed Yaver Imam** is our Executive Director of our Company and has been designated as the Director – Global Product Group, pursuant to an agreement dated May 31, 2019 entered into between our Company and Syed Yaver

Imam. In the past, he has been designated as a Non-executive director on our Board from June 1, 2019 to March 31, 2021. Our Board has redesignated him as an Executive Director with effect from April 1, 2021, in accordance with applicable law. He holds a bachelor's degree in civil engineering from the Jadavpur University and has completed a short-term course in mineral processing from Indian School of Mines, Dhanbad. He has been associated with our Company since 2005.

**Hemant Madhusudan Nerurkar** is an Independent Director of our Company. He has completed a degree course in metallurgy engineering from the University of Poona. He has been associated with our Company since 2014.

**Jagdishwar Prasad Sinha** is an Independent Director of our Company. He holds a bachelor's degree in technology (mechanical engineering) from Banaras Hindu University and a master's degree in business administration from the University of Pittsburgh. He has completed his term as an advanced leadership initiative fellow from the Harvard University. He was previously associated with companies located in India and abroad, including, The Tata Iron and Steel Company Limited, Tata Timken Limited, Timken India Limited, Schaeffler Technologies AG & Co., Ace Automation Control Equipment Private Limited, Caparo Maruti Limited, and Tudor India Limited.

**Madhu Dubhashi** is an Independent Director of our Company. She holds a bachelor's degree in arts from the University of Delhi and a post graduate diploma in business administration from the Indian Institute of Management, Ahmedabad. She was previously associated with Global Data Services of India Limited.

**Rudolph Michael Edge** is an Independent Director of our Company. He holds a bachelor's degree in technology (chemical engineering) from Nagpur University. He was previously associated with FLSmith Private Limited as an executive vice chairman.

#### **Arrangement or Understanding with major shareholders, customers, suppliers or others**

There is no arrangement or understanding with the major shareholders, customers, suppliers or others, pursuant to which any of our Directors were appointed on the Board. For details, see "*History and Certain Corporate Matters*" on page 170.

#### **Relationship between Directors and Key Managerial Personnel**

Except for Madan Mohan Mohanka and Mehul Mohanka who are related to each other as father and son, there is no family relationship between any of our Directors, Key Managerial Personnel or any of our Directors and Key Managerial Personnel.

#### **Terms of Appointment of our Executive Directors**

##### ***Madan Mohan Mohanka***

Madan Mohan Mohanka was reappointed as the Chairman and the Executive Director of our Company for a period of five years with effect from March 1, 2017, pursuant to resolutions passed by our Board and Shareholders on February 2, 2017 and March 1, 2017, respectively, and an agreement dated March 1, 2017 entered into between Madan Mohan Mohanka and our Company ("*Executive Chairman's Agreement*"). Pursuant to the amendment to the Executive Chairman's Agreement dated August 13, 2019, the Shareholders' resolution dated September 20, 2019 and the Board resolution dated November 10, 2021, Madan Mohan Mohanka is entitled to the following remuneration and perquisites with effect from April 1, 2021.

*Salary:* ₹1.79 million per month

*Special allowance:* ₹0.80 million per month

*Perquisites:* The perquisites payable to Madan Mohan Mohanka are as follows –

- i. House rent allowance: Equivalent to 50% of the salary or rent free furnished residential accommodation;
- ii. Reimbursement of all expenses for using facilities and amenities such as air conditioners, stoves, geysers, gas, electricity, water, etc.;
- iii. Reimbursement of all expenses incurred (including insurance premium to medical benefits association) and hospital, nursing, dental, optical treatment for Madan Mohan Mohanka and his family, subject to the

condition that the total costs thereof shall not exceed his one month's salary in a year or three months' salary over a period of three years. The term "family" shall mean spouse of Madan Mohan Mohanka;

- iv. Leave travel concession to Madan Mohan Mohanka and his family once in a year to and from any destination in India and/or abroad when proceeding on leave or returning therefrom in accordance with the rules of the Company;
- v. Subscription to clubs;
- vi. Benefit of personal accident insurance;
- vii. Earned leave encashment at the end of the tenure as per the rules of the Company;
- viii. Provision of use of car by Madan Mohan Mohanka for Company's business and telephone at his residence (except for personal long distance calls);
- ix. Reimbursement of all costs, charges and expenses that may be incurred by Madan Mohan Mohanka for the purposes of the business of the Company

*Additional incentive:* Eligible for an additional incentive of up to ₹4.00 million or more for Financial Year 2022 based on his performance.

### ***Mehul Mohanka***

Mehul Mohanka was reappointed as the Managing Director and Group CEO of our Company for a period of five years with effect from April 12, 2018, pursuant to resolutions passed by our Board and Shareholders on March 15, 2018 and October 23, 2018, respectively, and an agreement dated April 9, 2018 entered into between Mehul Mohanka and our Company ("***Managing Director's Agreement***"). Pursuant to the amendment to the Managing Director's Agreement dated August 13, 2019, the Shareholders' resolution dated September 20, 2019 and the Board resolution dated November 10, 2021, Mehul Mohanka is entitled to the following remuneration and perquisites with effect from April 1, 2021.

*Salary:* ₹0.85 million per month

*Perquisites:* The perquisites payable to Mehul Mohanka are as follows –

- i. Reimbursement of all expenses incurred (including insurance premium under the group medical insurance policy of the Company) and hospital, nursing home, dental, optical treatment for Mehul Mohanka and his family, subject to the condition that the total costs thereof shall not exceed his one month's salary in a year;
- ii. Leave travel concession to Mehul Mohanka and his family once in a year to and from any destination in India and/or abroad when proceeding on leave or returning therefrom in accordance with the rules of the Company. The term "family" shall mean spouse of Mehul Mohanka, his dependent children and his dependent parents;
- iii. Subscription to clubs – fees of not more than two clubs but not admission and life membership fees thereof;
- iv. Benefit of personal accident insurance in accordance with Company's rules;
- v. Contribution to provident fund and superannuation fund;
- vi. Gratuity, applicable, which shall not exceed half a month's salary for each completed year of service;
- vii. Earned leave encashment at the end of the tenure as per the rules of the Company;
- viii. Provision of use of car by Mehul Mohanka for Company's business and telephone at his residence (except for personal long distance calls);
- ix. Reimbursement of all costs, charges and expenses that may be incurred by Mehul Mohanka for the purposes of the business of the Company;

- x. Contribution of up to 10% of Mehul Mohankas’ salary per month to national pension scheme by the Company;

*Additional incentive:* Eligible for an additional incentive of up to ₹4.00 million or more payable to Mehul Mohanka basis the decision of the Nomination and Remuneration Committee for his performance.

### **Syed Yaver Imam**

Pursuant to an agreement dated May 31, 2019 entered into between our Company and Syed Yaver Imam, (“**Retainership Agreement**”), he is entitled to receive a monthly retainership fee of ₹0.92 million which has been revised to ₹1.08 million with effect from April 1, 2021 pursuant to a Board resolution passed on November 10, 2021. Pursuant to the Retainership Agreement, Syed Yaver Imam is also entitled to reimbursement of all reasonable and necessary expenses in connection with performance of his duties. Further, he is entitled to participate in any pre-agreed medical insurance plans, and his wife and two dependent children, along with him, are entitled for coverage under a medi-claim floater policy. For details in relation to the success fee payable to Syed Yaver Imam, see “– **Bonus or profit sharing plan for our Directors**” below

### **Compensation paid to our Executive Directors**

The compensation details in relation to our Executive Directors for the Financial Year 2021 are set forth below:

<b>Name of our Director</b>	<b>Compensation paid (in ₹ million)</b>
Mr. Madan Mohan Mohanka	41.46
Mr. Mehul Mohanka	12.65

### **Remuneration to our Non-Executive Directors and Independent Directors**

Pursuant to a resolution passed by our Board on May 2, 2008, our Non-Executive Directors are entitled to receive a sitting fee of ₹20,000 for attending each meeting of our Board.

Details of the sitting fees and commission paid to our Non-Executive Directors and Independent Directors in Fiscal 2021 is set forth below:

<b>Name of our Director*</b>	<b>Amount paid (in ₹ million)</b>
Hemant Madhusudan Nerurkar	1.25
Rudolph Michael Edge	1.00
Syed Yaver Imam*	18.07

\* Syed Yaver Imam, who was designated as an Executive Director for the period from July 19, 2005 to May 31, 2019 and is currently an Executive Director on our Board, has in the past been designated as a Non-executive director on our Board from June 1, 2019 to March 31, 2021. Our Board has redesignated him as an Executive Director with effect from April 1, 2021, in accordance with applicable law.

### **Loans to Directors**

No loans have been availed by our Directors from our Company.

None of the beneficiaries of loans, advances and sundry debtors are related to our Directors of the Company.

### **Bonus or profit sharing plan for our Directors**

Our Company does not have a bonus or profit sharing plan for our Directors.

Pursuant to the Executive Chairman’s Agreement, as amended, Madan Mohan Mohanka is eligible to receive an additional incentive basis the Company’s performance and his individual performance at the end of the financial year. For details, see “– **Terms of Appointment of our Executive Directors – Madan Mohan Mohanka – Additional incentive**” above.

Pursuant to the Managing Director’s Agreement, as amended, Mehul Mohanka is eligible to receive an additional incentive basis the Company’s performance and his individual performance at the end of the financial year. For details, see “– **Terms of Appointment of our Executive Directors – Mehul Mohanka – Additional incentive**” above.

Pursuant to the Retainership Agreement, Syed Yaver Imam is entitled to receive a success fee of ₹6.70 million in relation to achievement of over-all annual company targets including for achievement of targets in relation to our



Subsidiary, Tega Chile and performance in Australia. This determination of success fees is based on organisational delivery and personal performance.

### Shareholding of our Directors in our Company

Except as disclosed in “*Capital Structure - Shareholding of our Directors and Key Managerial Personnel in our Company*” on page 92, none of our Directors hold any Equity Shares in our Company as on the date of this Red Herring Prospectus. Our Directors are not required to hold any qualification shares in the Company.

### Service contracts with Directors

Except the statutory benefits upon termination of their employment in our Company or superannuation, no officer of our Company including Directors, are entitled to any benefit upon termination of employment or superannuation. Except as disclosed below, there are no service contracts entered into with any Directors, which provide for benefits upon termination of employment.

Pursuant to the Retainership Agreement, the legal heirs of Syed Yaver Imam, on termination of the Retainership Agreement in the occasion of his death or disability in terms of the Retainership Agreement, are entitled to receive a base compensation for all the days actually worked by Syed Yaver Imam prior to such termination, which remain unpaid, as may be payable.

### Contingent and deferred compensation payable to Directors

There is no contingent or deferred compensation payable to our Directors, which does not form part of their remuneration.

### Confirmations

None of our Directors are or were a director of any listed company during the last five years preceding the date of this Red Herring Prospectus, whose shares have been, or were suspended from being traded on any of the stock exchanges during the term of their directorship in such company.

No consideration in cash or shares or otherwise has been paid or agreed to be paid to any of our Directors or to the firms, or companies in which they are interested in, by any person either to induce them to become or to help them qualify as a Director, or otherwise for services rendered by them or by the firm or company in which they are interested, in connection with the promotion or formation of our Company.

Except Madan Mohan Mohanka and Mehul Mohanka, none of our Directors are or was a director of any listed company which has been or was delisted from any stock exchange during the term of their directorship in such company. The details of the delisting are set forth below.

Particulars	Details
Name of the company	Marudhar Food & Credit Limited
Name of the stock exchange	The Calcutta Stock Exchange Limited
Date of delisting on the stock exchange	October 27, 2014
Compulsory or voluntary delisting	Voluntary delisting
Reasons for delisting	Voluntary delisting
Term of the directors in the company	Madan Mohan Mohanka: 16 years, with effect from May 26, 2005 Mehul Mohanka: 16 years, with effect from May 26, 2005

### Remuneration paid or payable to our Directors from our Subsidiaries

Except as disclosed below, none of our Directors has been paid any remuneration from our Subsidiaries, including any contingent or deferred compensation accrued for Fiscal 2021.

Name of our Director	Name of the Subsidiary	Compensation paid (in ₹ million)
Mehul Mohanka	Tega Holdings Pte Ltd	26.61

### Interest of Directors

All our Executive Directors and Non-Executive Directors may be deemed to be interested to the extent of remuneration and reimbursement of expenses, if any, payable to them by our Company and our Independent

Directors may be deemed to be interested to the extent of sitting fees and commission, if any, payable to them for attending meetings of our Board or committees thereof.

Our Directors may be interested to the extent of Equity Shares, if any, held by them, their relatives (together with other distributions in respect of Equity Shares), or held by the entities in which they are associated as partners, or that may be subscribed by or allotted to the companies, firms, ventures, trusts in which they are interested as promoters, directors, partners, proprietors, members or trustees, pursuant to the Issue and any dividend and other distributions payable in respect of such Equity Shares. For details, please see “– *Shareholding of our Directors*” above.

Our Executive Directors, Madan Mohan Mohanka and Mehul Mohanka are interested in our Company by the virtue of being our Promoters and by also being the directors on the board of and shareholders of our corporate Promoter, Nihal Fiscal Services Private Limited. Further, our Executive Directors, Madan Mohan Mohanka and Mehul Mohanka and our Non-Executive Director, Syed Yaver Imam may be interested in our Company by the virtue of being the directors on the board of our Subsidiaries, and to the extent of benefits accruing to them pursuant to the agreements entered into by them with our Company. For details, please see “– *Terms of Appointment of our Executive Directors*”, “– *Remuneration to Non-Executive Directors and Independent Directors*”, “– *Service contracts with Directors*” and “– *Bonus or profit sharing plan for our Directors*” above.

#### *Interest in property*

Except as stated below, none of our Directors are interested in any property acquired by our Company or proposed to be acquired by it.

Our Company, has entered into an indenture of assignment of lease dated March 25, 2021 with TPW Engineering Limited and West Bengal Electronics Industry Development Corporation Limited to acquire the leasehold rights over office space situated on 8<sup>th</sup> Floor, Plot No. 5, Block DP, Sector V, Bidhannagar, Kolkata 700 091. Our Directors, Madan Mohan Mohanka and Mehul Mohanka may be interested in the transaction to the extent of being shareholders and directors of our Company and being shareholders and/ or directors of TPW Engineering Limited.

#### *Interest in promotion of our Company*

Except for Madan Mohan Mohanka and Mehul Mohanka, none of our Directors has any interest in the promotion or formation of our Company, as on the date of this Red Herring Prospectus.

### **Changes in our Board during the last three years**

The changes in our Board during the three years immediately preceding the date of this Red Herring Prospectus are set forth below.

<b>Name of Director</b>	<b>Date of Change</b>	<b>Reasons</b>
Syed Yaver Imam	June 1, 2019	Change in designation from Executive Director to Non-Executive Director
Jaharlal Saha	October 8, 2020	Cessation of directorship
Syed Yaver Imam	April 1, 2021*	Designated as an Executive Director
Jagdishwar Prasad Sinha	May 1, 2021**	Appointment as an Independent Director
Madhu Dubhashi	May 1, 2021**	Appointment as an Independent Director
Manju Mohanka	August 3, 2021	Cessation of directorship
Dhiraj Poddar***	November 10, 2021	Cessation of directorship

\* Syed Yaver Imam, who was designated as an Executive Director for the period from July 19, 2005 to May 31, 2019 and is currently an Executive Director on our Board, has in the past been designated as a Non-executive director on our Board from June 1, 2019 to March 31, 2021. Our Board has redesignated him as an Executive Director with effect from April 1, 2021, in accordance with applicable law.

\*\* Appointed through a resolution passed by our Board on April 30, 2021 and regularized pursuant to a resolution passed by our Shareholders on August 7, 2021

\*\*\* As the SHA and Part B of the Articles of Association will automatically terminate upon Allotment of Equity Shares, Mr. Dhiraj Poddar has resigned as our Director prior to filing of the Red Herring Prospectus with the RoC.

### **Borrowing Powers**

Pursuant to our Articles of Association, subject to applicable laws and pursuant to the Board resolution dated August 22, 2014 and the special resolution passed by our Shareholders on September 29, 2014, our Board has been authorised to borrow sums of money for or on behalf of the Company, from time to time, from any persons, firms, bodies corporate, bankers, financial institutions or from other ways of advances, deposits, loans or otherwise

and whether unsecured or secured by mortgage, charge, hypothecation or lien or pledge on the Company's assets, whether moveable or immovable, so borrowed together with moneys, if any, already borrowed by the Company (apart from temporary loans obtained from the Company's bankers in the ordinary course of business) will or may exceed the aggregate of the paid capital of the Company and its free reserves which have not been set apart for any specific purposes, provided that the total amount up to which the moneys may be borrowed whether in foreign currency and/or Indian National Rupees, in whatever manner, for a sum not exceeding ₹5,000.00 million, together with interest, compound interest, accumulated interest, liquidated damages, commitment charges, and such other costs, charges, expenses, and other monies payable by the Company in terms of loans and any other documents entered into or proposed to be entered into between the Company and the lenders, agents, financial/investment institutions, banks, trustees, in respect to of the said loans/borrowings/debentures and containing such terms and conditions and covenants in respect of enforcement of security as may be stipulated in that behalf and agreed to between the Board and the lenders, agents, financial/investment institutions, banks and trustees.

### **Corporate Governance**

As on the date of this Red Herring Prospectus, there are eight Directors on our Board comprising three Executive Directors and five Non-Executive Directors including four Independent Directors (including one woman Director) on our Board. Our Board functions either as a full board or through various committees constituted to oversee specific functions. Our Company is in compliance with the corporate governance norms prescribed under the SEBI Listing Regulations and the Companies Act in relation to the composition of our Board and constitution of committees thereof.

Our Company undertakes to take all necessary steps to continue to comply with all the applicable requirements of SEBI Listing Regulations and the Companies Act.

### **Board committees**

Our Company has constituted the following Board committees in terms of the SEBI Listing Regulations, and the Companies Act:

- (a) Audit Committee;
- (b) Nomination and Remuneration Committee;
- (c) Stakeholders' Relationship Committee;
- (d) CSR Committee; and
- (e) Risk Management Committee

### ***Audit Committee***

The Audit Committee was last reconstituted by a resolution of the Board dated November 10, 2021. The Audit Committee is in compliance with Section 177 and other applicable provisions of the Companies Act and Regulation 18 of the SEBI Listing Regulations. The Audit Committee currently comprises of:

1. Madhu Dubhashi, Independent Director (Chairperson);
2. Rudolph Michael Edge, Independent Director (Member);
3. Hemant Madhusudan Nerurkar, Independent Director (Member);
4. Jagdishwar Prasad Sinha, Independent Director (Member); and
5. Mehul Mohanka, Managing Director & Group CEO (Member)

### ***Scope and terms of reference:***

The Audit Committee shall be responsible for, among other things, as may be required by the stock exchange(s) from time to time, the following:

### **Powers of Audit Committee**

The Audit Committee shall have powers, including the following:

1. to investigate any activity within its terms of reference;
2. to seek information from any employee;
3. to obtain outside legal or other professional advice; and
4. to secure attendance of outsiders with relevant expertise, if it considers necessary

### **Role of Audit Committee**

The role of the Audit Committee shall include the following:

1. oversight of financial reporting process and the disclosure of financial information relating to Tega Industries Limited (the “**Company**”) to ensure that the financial statements are correct, sufficient and credible;
2. recommendation to the board of directors of the Company (the “**Board**” or “**Board of Directors**”) for appointment, re-appointment, replacement, remuneration and terms of appointment of auditors of the Company and the fixation of the audit fee;
3. approval of payment to statutory auditors for any other services rendered by the statutory auditors;
4. examining and reviewing, with the management, the annual financial statements and auditor’s report thereon before submission to the Board for approval, with particular reference to:
  - (a) Matters required to be included in the director’s responsibility statement to be included in the Board’s report in terms of clause (c) of sub-section 3 of section 134 of the Companies Act, 2013;
  - (b) Changes, if any, in accounting policies and practices and reasons for the same;
  - (c) Major accounting entries involving estimates based on the exercise of judgment by management;
  - (d) Significant adjustments made in the financial statements arising out of audit findings;
  - (e) Compliance with listing and other legal requirements relating to financial statements;
  - (f) Disclosure of any related party transactions; and
  - (g) Modified opinion(s) in the draft audit report.
5. reviewing, with the management, the quarterly, half-yearly and annual financial statements before submission to the Board for approval;
6. reviewing, with the management, the statement of uses / application of funds raised through an issue (public issue, rights issue, preferential issue, etc.), the statement of funds utilized for purposes other than those stated in the Offer document / prospectus / notice and the report submitted by the monitoring agency monitoring the utilization of proceeds of a public or rights issue, and making appropriate recommendations to the Board to take up steps in this matter;
7. reviewing and monitoring the auditor’s independence and performance, and effectiveness of audit process;
8. approval or any subsequent modification of transactions of the Company with related parties and omnibus approval for related party transactions proposed to be entered into by the Company, subject to the conditions as may be prescribed, by the independent directors who are members of the Audit Committee;

**Explanation:** The term “related party transactions” shall have the same meaning as provided in Clause 2(zc) of the SEBI Listing Regulations and/or the applicable Accounting Standards and/or the Companies Act, 2013.

9. scrutiny of inter-corporate loans and investments;
10. valuation of undertakings or assets of the Company, wherever it is necessary;
11. evaluation of internal financial controls and risk management systems;
12. reviewing, with the management, performance of statutory and internal auditors, and adequacy of the internal control systems;
13. reviewing the adequacy of internal audit function, if any, including the structure of the internal audit department, staffing and seniority of the official heading the department, reporting structure coverage and frequency of internal audit;
14. discussion with internal auditors of any significant findings and follow-up thereon;
15. reviewing the findings of any internal investigations by the internal auditors into matters where there is suspected fraud or irregularity or a failure of internal control systems of a material nature and reporting the matter to the Board;
16. discussion with statutory auditors before the audit commences, about the nature and scope of audit as well as post-audit discussion to ascertain any area of concern;
17. looking into the reasons for substantial defaults in the payment to depositors, debenture holders, shareholders (in case of non-payment of declared dividends) and creditors;
18. reviewing the functioning of the whistle blower mechanism;
19. monitoring the end use of funds raised through public offers and related matters; overseeing the vigil mechanism established by the Company, with the chairman of the Audit Committee directly hearing grievances of victimization of employees and directors, who used vigil mechanism to report genuine concerns in appropriate and exceptional cases;
20. approval of appointment of chief financial officer (i.e., the whole-time finance Director or any other person heading the finance function or discharging that function) after assessing the qualifications, experience and background, etc. of the candidate;
21. reviewing the utilization of loans and/or advances from/investment by the holding company in the subsidiary exceeding ₹1,000,000,000 or 10% of the asset size of the subsidiary, whichever is lower including existing loans/ advances/ investments existing as on the date of coming into force of this provision; and
22. considering and commenting on rationale, cost-benefits and impact of schemes involving merger, demerger, amalgamation etc., on the listed entity and its shareholders;
23. carrying out any other functions required to be carried out by the Audit Committee as may be decided by the Board and/or as provided under the Companies Act, 2013, the SEBI Listing Regulations or any other applicable law, as and when amended from time to time.

Audit Committee shall mandatorily review the following information:

1. Management discussion and analysis of financial condition and results of operations;
2. Statement of significant related party transactions (as defined by the Audit Committee), submitted by management;
3. Management letters / letters of internal control weaknesses issued by the statutory auditors;
4. Internal audit reports relating to internal control weaknesses;

5. The appointment, removal and terms of remuneration of the chief internal auditor; and
6. Statement of deviations in terms of the SEBI Listing Regulations:
  - (a) quarterly statement of deviation(s) including report of monitoring agency, if applicable, submitted to stock exchange(s) where the Equity Shares are proposed to be listed in terms of the SEBI Listing Regulations;
  - (b) annual statement of funds utilised for purposes other than those stated in the offer document/ prospectus/ notice in terms of the SEBI Listing Regulations.

#### ***Nomination and Remuneration Committee***

The Nomination and Remuneration Committee was last reconstituted pursuant to a resolution passed by our Board on November 10, 2021. The composition and terms of reference of the Nomination and Remuneration Committee are in compliance with Section 178 and other applicable provisions of the Companies Act 2013 and Regulation 19 of the SEBI Listing Regulations. The Nomination and Remuneration Committee currently comprises of:

1. Hemant Madhusudan Nerurkar, Independent Director, (Chairperson);
2. Rudolph Michael Edge, Independent Director (Member); and
3. Madhu Dubhashi, Independent Director (Member)

#### ***Scope and terms of reference:***

The Nomination and Remuneration Committee shall be responsible for, among other things, the following:

1. Formulation of the criteria for determining qualifications, positive attributes and independence of a director and recommend to the board of directors of the Company (the “**Board**” or “**Board of Directors**”) a policy relating to the remuneration of the directors, key managerial personnel and other employees (“**Remuneration Policy**”);
2. Formulation of criteria for evaluation of performance of independent directors and the Board;
3. Devising a policy on Board diversity;
4. Identifying persons who are qualified to become directors and who may be appointed in senior management in accordance with the criteria laid down, and recommend to the Board their appointment and removal and carrying out evaluation of every director’s performance (including independent director);
5. Whether to extend or continue the term of appointment of the independent director, on the basis of the report of performance evaluation of independent directors;
6. Recommend to the board, all remuneration, in whatever form, payable to senior management;

The Nomination and Remuneration Committee, while formulating the remuneration policy, should ensure that:

1. the level and composition of remuneration be reasonable and sufficient to attract, retain and motivate directors of the quality required to run the Company successfully;

2. relationship of remuneration to performance is clear and meets appropriate performance benchmarks; and
3. remuneration to directors, key managerial personnel and senior management involves a balance between fixed and incentive pay reflecting short and long term performance objectives appropriate to the working of the Company and its goals.
4. perform such functions as are required to be performed by the Nomination and Remuneration Committee under the SEBI (Share Based Employee Benefits) Regulations, 2014, including the following:
  - (a) administering the ESOP Scheme, 2021 (the “**Plan**”);
  - (b) determining the eligibility of employees to participate under the Plan;
  - (c) granting options to eligible employees and determining the date of grant;
  - (d) determining the number of options to be granted to an employee;
  - (e) determining the exercise price under the Plan;
  - (f) construing and interpreting the Plan and any agreements defining the rights and obligations of the Company and eligible employees under the Plan, and prescribing, amending and/or rescinding rules and regulations relating to the administration of the Plan;
  - (g) formulate detailed terms and conditions of the Plan;
  - (h) adopt rules and regulations for implementing the Plan from time to time;
  - (i) determine the additional number of options to be granted to the employees;
  - (j) determine the vesting schedule within which the options shall vest with the employees;
  - (k) determine the conditions under which options vested in the employee may lapse in case of termination of employment with cause;
  - (l) determine the exercise period within which the participant should exercise the vested option and the period within which the vested option should lapse on the failure to exercise the vested options;
  - (m) determine the specified time period within which the participant shall exercise the vested options in event of termination or resignation of the participant;
  - (n) determine the right of a participant to exercise all the vested options at one time or various points in time within the exercise period;
  - (o) determine the procedure for making a fair and reasonable adjustment to the number of options and to the exercise price in case of corporate actions such as rights issue, bonus issues, split/consolidation and others; in the regard the following shall be taken into consideration in accordance with applicable laws;
  - (p) determine the grant, vesting and exercise of options in case of employees who are on long leave;
  - (q) determine the procedure for cash-less exercise of options, if any;
  - (r) alter/modify the vesting schedule and/or exercise price for subsequent grants;
  - (s) take any other actions and make any other determinations or decisions that it deems necessary or appropriate in connection with the Plan or the administration or interpretation thereof;
  - (t) decide all other matters that must be determined in connection with an option under the Plan; and
  - (u) administer and reconcile any inconsistency in the Plan.

5. frame suitable policies, procedures and systems to ensure that there is no violation of securities laws, as amended from time to time, including:
  - (a) the Securities and Exchange Board of India (Prohibition of Insider Trading) Regulations, 2015; and
  - (b) the Securities and Exchange Board of India (Prohibition of Fraudulent and Unfair Trade Practices Relating to the Securities Market) Regulations, 2003, by the trust, the Company and its employees, as applicable.
6. carrying out any other activities as may be delegated by the Board of Directors of the Company functions required to be carried out by the Nomination and Remuneration Committee as provided under the Companies Act, 2013, the SEBI Listing Regulations or any other applicable law, as and when amended from time to time.

#### ***Stakeholders' Relationship Committee***

The Stakeholders' Relationship Committee was constituted by a resolution of our Board dated April 30, 2021, in compliance with Section 178 and any other applicable law of the Companies Act 2013 and Regulation 20 of the SEBI Listing Regulations. The Stakeholders' Relationship Committee currently comprises of:

1. Jagdishwar Prasad Sinha, Independent Director (Chairperson);
2. Syed Yaver Imam, Executive Director (Member);
3. Hemant Madhusudan Nerurkar, Independent Director (Member);
4. Mehul Mohanka, Managing Director & Group CEO (Member)

#### ***Scope and terms of reference:***

The Stakeholders' Relationship Committee shall be responsible for, among other things, as may be required by the under applicable law, the following:

1. considering and looking into various aspects of interest of shareholders, debenture holders and other security holders
2. resolving the grievances of the security holders of the listed entity including complaints related to transfer/transmission of shares, non-receipt of annual report, non-receipt of declared dividends, issue of new/duplicate certificates, general meetings etc.;
3. giving effect to allotment of Equity Shares, approval of transfer or transmission of Equity Shares, debentures or any other securities;
4. issue of duplicate certificates and new certificates on split/consolidation/renewal, etc.;
5. review of measures taken for effective exercise of voting rights by shareholders;
6. review of adherence to the service standards adopted by the listed entity in respect of various services being rendered by the Registrar & Share Transfer Agent; and
7. review of the various measures and initiatives taken by the listed entity for reducing the quantum of unclaimed dividends and ensuring timely receipt of dividend warrants/annual reports/statutory notices by the shareholders of the company.
8. carrying out any other functions required to be carried out by the Stakeholders' Relationship Committee as contained in the SEBI Listing Regulations or any other applicable law, as and when amended from time to time

#### ***CSR Committee***

The CSR Committee was reconstituted by a resolution of our Board dated April 30, 2021 and its composition and terms of reference are in compliance with Section 135 and other applicable provisions of the Companies Act 2013.



The CSR Committee currently comprises of:

1. Rudolph Michael Edge, Independent Director (Chairperson);
2. Madan Mohan Mohanka, Chairman and Executive Director (Member);
3. Syed Yaver Imam, Executive Director (Member);

*Scope and terms of reference:*

1. formulate and recommend to the Board, a “Corporate Social Responsibility Policy” which shall indicate the activities to be undertaken by the Company as specified in Schedule VII of the Companies Act, 2013, as amended;
2. review and recommend the amount of expenditure to be incurred on the activities referred to in clause (a);
3. monitor the corporate social responsibility policy of the Company and its implementation from time to time; and
4. any other matter as the Corporate Social Responsibility Committee may deem appropriate after approval of the Board or as may be directed by the Board from time to time and/or as may be required under applicable law, as and when amended from time to time.

#### ***Risk Management Committee***

The Risk Management Committee was constituted by a resolution of our Board dated April 30, 2021 and its composition and terms of reference are in compliance with the requirements under Regulation 21 of SEBI Listing Regulations and other applicable provisions of the Companies Act 2013. The Risk Management Committee currently comprises of:

1. Mehul Mohanka, Managing Director & Group CEO, (Chairperson);
2. Rudolph Michael Edge, Independent Director (Member);
3. Syed Yaver Imam, Executive Director (Member);
4. Manoj Kumar Agarwal, Director- Global Finance and CFO (Member)

*Scope and terms of reference:*

1. Formulation of a detailed risk management policy which shall include: (a) a framework for identification of internal and external risks specifically faced by the listed entity, in particular including financial, operational, sectoral, sustainability (particularly, ESG related risks), information, cyber security risks or any other risk as may be determined by the Risk Management Committee; (b) measures for risk mitigation including systems and processes for internal control of identified risks; and (c) business continuity plan;
2. Ensure that appropriate methodology, processes and systems are in place to monitor and evaluate risks associated with the business of the Company;
3. Monitor and oversee implementation of the risk management policy, including evaluating the adequacy of risk management systems;
4. Periodically review the risk management policy, at least once in two years, including by considering the changing industry dynamics and evolving complexity, and recommend for any amendment or modification thereof, as necessary;
5. Keep the Board of directors of the Company informed about the nature and content of its discussions, recommendations and actions to be taken;
6. Review the appointment, removal and terms of remuneration of the chief risk officer (if any); and

7. To implement and monitor policies and/or processes for ensuring cyber security;
8. Any other similar or other functions as may be laid down by Board from time to time and/or as may be required under applicable law, as and when amended from time to time, including the Securities and Exchange Board of India (Listing Obligations and Disclosure Requirements) Regulations, 2015.

*[The remainder of this page has been left blank intentionally]*

## Management Organisation Structure

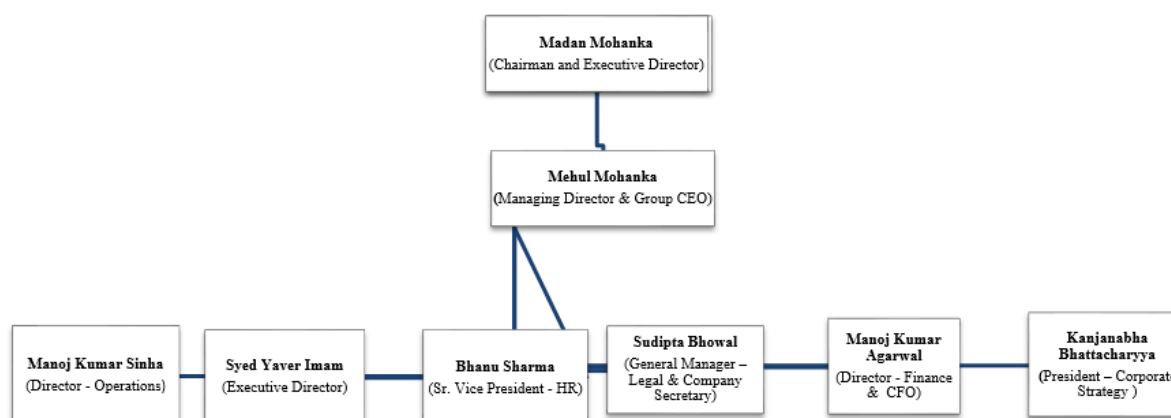

### Key Managerial Personnel

In addition to Madan Mohan Mohanka, Mehul Mohanka and Syed Yaver Imam, our Executive Directors, whose details are provided in “–*Brief Profiles of our Directors*” and “–*Compensation paid to our Executive Directors*” above, the details of our other Key Managerial Personnel as on the date of this Red Herring Prospectus are set forth below.

**Manoj Kumar Agarwal** is our Director Global Finance and Chief Financial Officer. He holds a bachelor’s degree in commerce from university of Calcutta. He is a member of the Institute of Company Secretaries of India and the Institute of Chartered Accountants of India. He joined our Company as President – Finance with effect from April 20, 2015 and has been associated with our Company for more than six years. He was previously associated with Sesa Sterlite Limited for almost a decade. In Fiscal 2021, he received an aggregate compensation of ₹10.35 million (which included ₹1.85 million for Fiscal 2020, paid in Fiscal 2021). Further, for Fiscal 2021, ₹2.45 million accrued as the annual variable pay, which will be payable in Fiscal 2022.

**Manoj Kumar Sinha** is our Director Operations. He holds a bachelor’s degree in engineering from Sambalpur University. He has been associated with our Company since September 28, 2015. He was previously associated with Tata Engineering and Locomotive Company Limited, New Holland Tractors (India) Private Limited and Sterling Generators Private Limited. In Fiscal 2021, he received an aggregate compensation of ₹10.17 million (which included ₹1.93 million for Fiscal 2020, paid in Fiscal 2021). Further, for Fiscal 2021, ₹2.33 million accrued as the annual variable pay, which will be payable in Fiscal 2022.

**Kanjanabha Bhattacharyya** is our President – Corporate Strategy. He holds a bachelor’s degree in metallurgical engineering from Jadavpur University and post graduate diploma in computer-aided management from Indian Institute of Management, Calcutta. He has been associated with our Company since April 5, 2021. He was previously associated with Outotec India Private Limited, Boston Consulting Group (India) Private Limited and Siemens VAI Metals Technology Private Limited. Since he joined our Company in Fiscal 2022, no amount was paid to him in Fiscal 2021.

**Bhanu Sharma** is our Senior Vice-President – Human Resources & Administration. He holds a bachelor’s degree in science from the Panjab University, master’s degree in computer application from Punjab Technical University and a post graduate diploma in management from Management Development Institute, Gurgaon. He has been associated with our Company with effect from August 2, 2021. He was previously associated with Express Knowledge Communications Solutions Private Limited and JSW Energy Limited. Since he joined our Company in Fiscal 2022, no amount was paid to him in Fiscal 2021.

**Sudipta Bhowal** is the General Manager – Legal & Company Secretary of our Company. He is also the compliance officer of our Company. He holds a bachelor’s degree in commerce from the Calcutta University and in law from Sambalpur University along with a post graduate diploma in business administration from Symbiosis Centre for Distance Learning. He is a member of the Institute of Company Secretaries of India and has completed the secretarial modular training program organised by Eastern India Regional Council, Institute of Company Secretaries of India. He has been associated with our Company since June 18, 2018 and has been our company

secretary with effect from September 1, 2018. He was previously associated with Haldia Petrochemicals Limited, Kesoram Industries Limited and Globsyn Technologies Limited. In Fiscal 2021, he received an aggregate compensation of ₹2.89 million (which included ₹0.49 million for Fiscal 2020, paid in Fiscal 2021). Further, for Fiscal 2021, ₹0.56 million accrued as the annual variable pay, which will be payable in Fiscal 2022.

### **Status of Key Managerial Personnel**

Except for our Executive Directors, all the Key Managerial Personnel are permanent employees of our Company.

### **Bonus or profit-sharing plan for the Key Managerial Personnel**

Except for the payments and compensation required to be paid under the laws of India, there is no profit sharing plan for the Key Managerial Personnel of our Company. However, our employees are paid annual variable pay basis factors such as, organisational deliverables and personal performance, segregated in various bands. In Fiscal 2021, our Company has not granted any benefit on an individual basis to any of our Key Managerial Personnel other than the remuneration paid to them and the compensation required to be paid under the laws of India for such period.

### **Shareholding of Key Managerial Personnel in our Company**

Except as disclosed in “*Capital Structure - Shareholding of our Directors and Key Managerial Personnel in our Company*” on page 92, none of our Key Managerial Personnel hold any Equity Shares in our Company as on the date of this Red Herring Prospectus.

### **Attrition of Key Managerial Personnel**

The attrition of Key Managerial Personnel is not high in our Company compared to the industry.

### **Service Contracts with Key Managerial Personnel**

Except as stated above under “– *Service contracts with Directors*”, our Company has not entered into any service contracts, pursuant to which its Key Managerial Personnel, are entitled to benefits upon termination of employment and except statutory benefits upon termination of their employment in our Company or superannuation, no Key Managerial Personnel, is entitled to any benefit upon termination of employment or superannuation.

### **Contingent and deferred compensation payable to Key Managerial Personnel**

There is no contingent or deferred compensation payable to our Key Managerial Personnel, which does not form part of their remuneration.

### **Arrangements and understanding with major shareholders, customers, suppliers or others**

None of the Key Managerial Personnel of our Company has been appointed pursuant to any arrangement or understanding with our major shareholders, customers, suppliers or others.

### **Interest of Key Managerial Personnel**

Except as disclosed above in relation to our Executive Directors, none of our Key Managerial Personnel has any interest in our Company except to the extent of their remuneration, shares allotted or options granted pursuant to any employee stock option schemes, benefits, reimbursement of expenses incurred by them in the ordinary course of business.

### **Changes in Key Managerial Personnel during the last three years**

The changes in our Key Managerial Personnel during the three years immediately preceding the date of this Red Herring Prospectus are set forth below:

<b>Name</b>	<b>Date of change</b>	<b>Reason</b>
Rakhi Sarkar	August 31, 2018	Cessation of services as the company secretary
Sudipta Bhowal	September 1, 2018	Appointment as the company secretary

**Employee stock option and stock purchase schemes**

For details of the employee stock option scheme of our Company, see “*Capital Structure – Employee Stock Option Plan*” on page 93.

**Payment or Benefit to Key Managerial Personnel of our Company**

No amount or benefit has been paid or given to any officer of our Company within the two years preceding the date of this Red Herring Prospectus or is intended to be paid or given, other than in the ordinary course of their employment.

## PROMOTER AND PROMOTER GROUP

The Promoters of our Company are, Madan Mohan Mohanka, Manju Mohanka, Manish Mohanka, Mehul Mohanka and NFSPL. As on the date of this Red Herring Prospectus, our Promoters in aggregate hold 55,161,483 Equity Shares, constituting 83.21% of the pre-Offer issued, subscribed and paid-up Equity Share capital of our Company. For details of shareholding of our Promoters in our Company, see “*Capital Structure*” on page 79.

### Details of our individual Promoters

#### *Madan Mohan Mohanka*



**Madan Mohan Mohanka**, born on August 13, 1943, is aged 78 years and is a citizen of India. He resides at 146, Block- G, New Alipore, Kolkata 700 053. He is an Executive Director and Chairman of our Company. For further details, see “*Management - Brief Profiles of our Directors*” on page 182.

His PAN number is ABLPM7436J and his Aadhaar card number is 6122 2075 3918.

#### *Manju Mohanka*



Manju Mohanka, born on February 21, 1949, is aged 72 years and is a citizen of India. She resides at 146, Block- G, New Alipore, Kolkata 700 053. Prior to her cessation of directorship on the Board of our Company, Manju Mohanka was a Director on our Board from October 30, 2009 to August 3, 2021. Further, she is also a director on the boards of TPW Engineering Limited, Maple Orgtech (India) Limited and MM Rosewood Buildinfra Private Limited.

Her PAN number is AEOPM9853P and her Aadhaar card number is 3667 8478 6213.

#### *Manish Mohanka*



Manish Mohanka, was born on May 20, 1971, is aged 50 years and is a citizen of India. He resides at 146, Block- G, New Alipore, Kolkata 700 053. He holds a bachelor’s degree in commerce from University of Calcutta. Manish Mohanka is a director on the board of TPW Engineering Limited and MM Aqua Technologies Limited.

His PAN number is AEAPM1550K and his Aadhaar card number is 7023 4116 4647.

### ***Mehul Mohanka***



Mehul Mohanka, was born on February 3, 1975, is aged 46 years and is a citizen of India. He resides at 146, Block- G, New Alipore, Kolkata 700 053. He is the Managing Director and Group CEO of our Company. For details, see “***Management - Brief Profiles of our Directors***” on page 182.

His PAN number is AFDPM0572R, driving license number is WB 011993588605 and his Aadhaar card number is 7291 8701 0269.

Our Company confirms that the respective PAN numbers, bank account numbers and the passport numbers of each of our individual Promoters, to the extent available have been submitted to the Stock Exchanges at the time of filing of the Draft Red Herring Prospectus.

### **Change of control of our Company**

While there has been no change in control of our Company in the last five years preceding the date of this Red Herring Prospectus, Mehul Mohanka and Manju Mohanka have been identified as Promoters of our Company, in addition to Madan Mohan Mohanka, Manish Mohanka and NFSPL, pursuant to a resolution passed by our Board on April 30, 2021.

### **Details of our corporate Promoter**

#### ***Nihal Fiscal Services Private Limited***

##### *Corporate Information*

NFSPL was incorporated on April 30, 1996 under the Companies Act, 1956 as a private limited Company at Kolkata, West Bengal, pursuant to a certificate of incorporation issued by the RoC. Its registered office is located at 40/1A, Block-B, New Alipore, Kolkata 700 053. NFSPL has obtained a certificate of registration dated April 10, 2003 from the RBI to act as a NBFC (without accepting public deposits). It is primarily engaged in carrying on the business of activities auxiliary to financial intermediation. There has been no change in the business of NFSPL since its incorporation.

As on the date of this Red Herring Prospectus, NFSPL holds 36,553,153 Equity Shares constituting 55.14% of the pre-Offer Equity Share capital of our Company. For details in relation to the purchase of Equity Shares by NFSPL of our Company, see “***History and Certain Corporate Matters***” and “***Capital Structure***” on pages 170 and 79, respectively.

##### *Promoters of our corporate Promoter*

As on the date of this Red Herring Prospectus, the promoters of NFSPL are:

1. Madan Mohan Mohanka
2. Manju Mohanka
3. Manish Mohanka
4. Marudhar Food & Credit Limited

##### *Board of directors of our corporate Promoter*

As on the date of this Red Herring Prospectus, the board of directors of NFSPL comprises of:

1. Madan Mohan Mohanka; and
2. Mehul Mohanka.

*Capital structure and shareholding pattern of our corporate Promoter*

The issued, subscribed and paid-up capital of NFSPL is ₹21,284,430 divided into 2,128,443 equity shares of ₹10 each.

The shareholding pattern of NFSPL is as follows:

S.no.	Name of Shareholders	Number of equity shares	% of the total equity share capital
1.	Manju Mohanka	1,069,035	50.23
2.	Madan Mohan Mohanka	289,940	13.62
3.	Manish Mohanka	410,903	19.31
4.	Marudhar Food & Credit Limited	356,755	16.76
5.	Mehul Mohanka	1,810	0.08
<b>Total</b>		<b>2,128,443</b>	<b>100.00</b>

NFSPL has filed the Scheme before the NCLT for, among others, a proposed amalgamation with Marudhar, a member of our Promoter Group. On approval of the Scheme in accordance with applicable law, the equity shareholding of NFSPL in our Company will increase to the extent of the equity shareholding of Marudhar in our Company. As on the date of this Red Herring Prospectus, Marudhar holds 1.96% of our shareholding while NFSPL holds 55.14% of our shareholding and post the approval of the Scheme, the resultant shareholding of NFSPL will aggregate to 57.10% of our issued, subscribed and paid-up share capital. For details, see “**Risk Factors - One of our Promoters, Nihal Financial Services Private Limited will undergo a corporate restructuring resulting in, amongst others, a change in its equity shareholding in our Company. We cannot assure you that the relevant approvals in relation to such corporate restructuring will be obtained or estimate the time involved in its implementation.**” on page 39.

*Details of change in control*

There has been no change in the control of NFSPL in the last three years preceding the date of this Red Herring Prospectus.

Our Company confirms that the PAN, bank account number(s) and corporate registration number of NFSPL and the address of the registrar of companies where our corporate Promoter is registered, will be submitted to the Stock Exchanges at the time of filing this Red Herring Prospectus.

**Interests of our Promoters**

Our Promoters are interested in our Company to the extent (i) that they have promoted our Company; (ii) in case of individual Promoters, of being directors of our Company, our corporate Promoter and our Subsidiaries and receiving sitting fees, remuneration, benefits and reimbursement of expenses payable to them in such capacity; (iii) their shareholding and in case of individual Promoters, the shareholding of their relative in our Company; and (iv) the dividends payable (if any) and other distributions in respect of the Equity Shares held by them. For details on aforementioned directorships of our individual Promoters and shareholding of our Promoters in our Company, see “**Our Management**” and “**Capital Structure – Notes to Capital Structure – History of the Equity Share Capital held by our Promoters**” on pages 180 and 84, respectively. For further details of interest of our Promoters in our Company, see “**Financial Information**” beginning on page 207.

Except as stated under “**Our Management - Interest of Directors - Interest in property**”, our Promoters have no interest in any property acquired by our Company during the three years preceding the date of this Red Herring Prospectus, or proposed to be acquired, or in any transaction by our Company for acquisition of land, construction of building or supply of machinery.

Our Promoters are not interested as members of a firm or company (other than our Company) and no sum has been paid or agreed to be paid to our Promoters or to such firm or company in cash or shares or otherwise by any person, either to induce any of our Promoters to become, or qualify them as a director, or otherwise, for services rendered by such Promoter(s) or by such firm or company in connection with the promotion or formation of our Company.



### **Payment of Benefits to our Promoters or Promoter Group**

Except as stated otherwise in “*Our Management - Compensation paid to our Executive Directors*”, “*- Interests of our Promoter*” and “*Financial Information*” on pages 185, 201 and 207, respectively, no benefit or amount has been given or paid to our Promoters or members of our Promoter Group within the two years immediately preceding the date of filing this Red Herring Prospectus or is intended to be paid or given to our Promoters or members of our Promoter Group.

### **Experience in the business of our Company**

For details in relation to experience of Madan Mohan Mohanka and Mehul Mohanka in the business of our Company, see “*Our Management – Brief Profiles of Directors*” on page 182. For details in relation to experience of Manju Mohanka, Manish Mohanka and NFSPL in the business of our Company, see “*– Details of our Promoters*” above.

### **Material Guarantees**

Our Promoters have not given any material guarantee to any third party with respect to the Equity Shares, as on the date of this Red Herring Prospectus.

### **Companies or Firms with which our Promoters have disassociated in the last three years**

Except as disclosed below, our Promoters have not disassociated themselves from any company or firm during the last three years preceding the date of this Red Herring Prospectus.

<b>Name of the Entity</b>	<b>Reason for Disassociation</b>	<b>Date of Disassociation</b>
Tega Scanning Solutions Inc.	Divestment of Stake	January 15, 2019

### **Promoter Group**

As on the date of this Red Herring Prospectus, the following is the list of persons constituting the promoter group of our Company:

#### ***Individuals forming part of the Promoter Group***

As on the date of this Red Herring Prospectus, the persons forming a part of our Promoter Group (other than our individual Promoters), are as follows:

<b>S.no.</b>	<b>Name of Promoter</b>	<b>Name of relative</b>	<b>Relationship</b>
1.	Madan Mohan Mohanka		<i>Nil</i>
2.	Manju Mohanka		<i>Nil</i>
3.	Manish Mohanka		<i>Nil</i>
4.	Mehul Mohanka	Arvan Mohanka	Son
		Amarya Mohanka	Daughter

Nameeta Radhu and her parents, Deo Raj and Nirupama Raj disassociated with our Promoter, Mehul Mohanka and therefore have not been considered within the definition of ‘promoter group’ under Regulation 2(1)(pp) of the SEBI ICDR Regulations. SEBI, by letter dated October 29, 2021 granted exemption to our Company from including Nameeta Radhu and her parents, Deo Raj and Nirupama Raj as members of the Promoter Group.

#### ***Entities forming part of the Promoter Group***

As on the date of this Red Herring Prospectus, the entities forming a part of our Promoter Group (other than our corporate Promoter), as follows:

S.no.	Name of entity
1.	Maple Orgtech (India) Limited*
2.	Marudhar**
3.	MM Aqua Technologies Limited*
4.	MM Group Holding Private Limited
5.	MM Rosewood Buildinfra Private Limited
6.	Tega Parks and Resorts Private Limited
7.	TPW Engineering Limited
8.	Trafalgar Consulting International Company Private Limited

\* In accordance with the Scheme MM Aqua Technologies Limited and Maple Orgtech (India) Limited will de-merge from NFSPL to amalgamate with MM Group Holdings Private Limited. For details, see “**Risk Factors - One of our Promoters, Nihal Financial Services Private Limited will undergo a corporate restructuring resulting in, amongst others, a change in its equity shareholding in our Company. We cannot assure you that the relevant approvals in relation to such corporate restructuring will be obtained or estimate the time involved in its implementation.**” on page 39.

\*\* Post the approval of the Scheme in accordance with applicable law, Marudhar will amalgamate with NFSPL and will cease to exist as a member of our Promoter Group. For details, see “- **Description of corporate Promoter**” above.

## GROUP COMPANIES

As per the SEBI ICDR Regulations and the applicable accounting standards, for the purpose of identification of group companies, our Company has considered (i) the companies (other than the Promoters and Subsidiaries) with which there are related party transactions as disclosed in the Restated Consolidated Financial Information; and (ii) other companies considered material by our Board pursuant to the Materiality Policy. In accordance with our Materiality Policy, for the purposes of disclosure in this Red Herring Prospectus, our Company has considered the companies (other than Promoters and Subsidiaries) with which there were related party transactions, during the period for which Restated Consolidated Financial Information is disclosed in this Red Herring Prospectus and any other companies as may be considered as material by the Board.

Accordingly, as on the date of this Red Herring Prospectus, our Board has identified four Group Companies, the details of which are set forth below:

1. Hosch Equipment (India) Ltd;
2. Maple Orgtech (India) Limited;
3. MM Aqua Technologies Limited; and
4. TPW Engineering Limited

### **Details of our Group Companies**

#### ***Hosch India***

The registered office of Hosch India is situated at 807, Godrej Waterside, Tower II, 8<sup>th</sup> Floor, Plot No. 5, Block DP, Salt Lake Electronics Complex, Sector V, Kolkata 700 091, West Bengal.

The details of the reserves (excluding revaluation reserves), sales, profit/(loss) after tax, basic earnings per share, diluted earnings per share and net asset value per share derived from the audited financial statements of Hosch India for financial years ended March 31, 2021, March 31, 2020 and March 31, 2019 in terms of the SEBI ICDR Regulations are available on its website at <https://hoschonline.com/>

#### ***Maple Orgtech (India) Limited (“Maple Orgtech”)***

The registered office of Maple Orgtech is situated at 147, Block-G, New Alipore, Kolkata- 700 053, West Bengal.

The details of the reserves (excluding revaluation reserves), sales, profit/(loss) after tax, basic earnings per share, diluted earnings per share and net asset value per share derived from the audited financial statements of Maple Orgtech for financial years ended March 31, 2021, March 31, 2020 and March 31, 2019 in terms of the SEBI ICDR Regulations are available on its website at <https://www.mapleorgtech.com/>.

#### ***MM Aqua Technologies Limited (“MM Aqua”)***

The registered office of MM Aqua is situated at Behrampur Road, Khandasa, Gurgaon -122 001, Haryana.

The details of the reserves (excluding revaluation reserves), sales, profit/(loss) after tax, basic earnings per share, diluted earnings per share and net asset value per share derived from the audited financial statements of MM Aqua for financial years ended March 31, 2021, March 31, 2020 and March 31, 2019 in terms of the SEBI ICDR Regulations are available on its website at <https://mmaqua.in/>.

#### ***TPW Engineering Limited (“TPW Engineering”)***

The registered office of TPW Engineering is situated at 40/1A, Block-B, New Alipore, Kolkata-700 053, West Bengal.

The details of the reserves (excluding revaluation reserves), sales, profit/(loss) after tax, basic earnings per share, diluted earnings per share and net asset value per share derived from the audited financial statements of TPW Engineering for financial years ended March 31, 2021, March 31, 2020 and March 31, 2019 in terms of the SEBI ICDR Regulations are available on its website at <http://tpwengineering.in/>.

### **Interests of our Group Companies**

As on the date of this Red Herring Prospectus:

- a. Our Group Companies do not have any interest in the promotion or formation of our Company.
- b. Except as set forth in “*Restated Consolidated Financial Information – Annexure V – Note 46*” beginning on page 287, our Group Companies do not have any interest in any property acquired by our Company within the three years immediately preceding the date of filing this Red Herring Prospectus or proposed to be acquired by our Company as on the date of filing this Red Herring Prospectus.
- c. Our Group Companies do not have any interest in any transaction by our Company pertaining to acquisition of land, construction of building and supply of machinery, etc.

Except as set forth in “*Restated Consolidated Financial Information – Annexure V – Note 46*” beginning on page 287, our Group Companies have no business interest in our Company.

### **Common Pursuits between our Group Companies and our Company**

There are no common pursuits between our Group Companies and our Company.

### **Related business transactions**

Except as set forth in “*Restated Consolidated Financial Information – Annexure V – Note 46*” beginning on page 287, there are no related business transactions with our Group Companies.

### **Litigation involving our Group Companies**

As on the date of this Red Herring Prospectus, there are no litigation involving our Group Companies which has a material impact on our Company.

## **DIVIDEND POLICY**

The declaration and payment of dividend on our Equity Shares, if any, will be recommended by our Board and approved by our Shareholders, at their discretion, subject to the provisions of our Articles of Association and the applicable laws including the Companies Act, 2013 together with the applicable rules issued thereunder. The dividend distribution policy of our Company was approved and adopted by our Board on August 3, 2021 (“**Dividend Policy**”). In terms of the Dividend Policy, the dividend, if any, will depend on a number of internal and external factors, which, amongst others, include, (i) consolidated net operating profit after tax; (ii) capital expenditure requirements; (iii) resources required to fund acquisitions and / or new businesses; (iv) cash flow required to meet contingencies; (v) prevailing legal requirements, regulatory conditions or restrictions laid down under the applicable laws including tax laws; (vi) dividend pay-out ratios of companies in the same industry; and (vii) significant changes in macro-economic environment materially affecting the business in which the Company is engaged in the geographies in which the Company operates. Further, our Board may not declare or recommend dividend for a particular period if it is of the view that it would be prudent to conserve capital for the then ongoing or planned business expansion or other factors which may be considered by the Board.

We have not declared and paid any dividends on the Equity Shares in any of the three Financial Years preceding the date of the Draft Red Herring Prospectus and until the date of this Red Herring Prospectus. However, we have paid an amount of ₹500.00 as dividend in relation to the CCPP in accordance with the SHA, in each of the Financial Years ended March 31, 2019, March 31, 2020 and March 31, 2021. The dividend history in the past is not necessarily indicative of our dividend amounts, if any, in the future.

**SECTION V – FINANCIAL INFORMATION**  
**RESTATED CONSOLIDATED FINANCIAL INFORMATION**

*[The remainder of this page has intentionally been left blank]*

# Price Waterhouse & Co Bangalore LLP

## Chartered Accountants

To  
The Board of Directors  
Tega Industries Limited  
147, Block-G, New Alipore  
Kolkata- 700 053

### **Independent Auditor's Examination Report on Restated Consolidated Financial Information in connection with the Initial Public Offering of Tega Industries Limited**

Dear Sirs,

1. This report is issued in accordance with the terms of our agreement dated August 10, 2021.
2. We have examined the attached Restated Consolidated Financial Information, expressed in Indian Rupees in millions of Tega Industries Limited (hereinafter referred to as the "Company" or the "Holding Company" or the "Issuer") and its subsidiaries (the Company and its subsidiaries together referred to as the "Group") and its joint venture, comprising:
  - (a) the "Restated Consolidated Statement of Assets and Liabilities" as at June 30, 2021, March 31, 2021, March 31, 2020 and March 31, 2019 (enclosed as Annexure I);
  - (b) the "Restated Consolidated Statement of Profit and Loss" for the three months period ended June 30, 2021 and for the years ended March 31, 2021, March 31, 2020 and March 31, 2019 (enclosed as Annexure II);
  - (c) the "Restated Consolidated Statement of Changes in Equity" for the three months period ended June 30, 2021 and for the years ended March 31, 2021, March 31, 2020 and March 31, 2019 (enclosed as Annexure III);
  - (d) the "Restated Consolidated Statement of Cash Flows" for the three months period ended June 30, 2021 and for the years ended March 31, 2021, March 31, 2020 and March 31, 2019 (enclosed as Annexure IV);
  - (e) the "Notes to Restated Consolidated Financial Information" for the three months period ended June 30, 2021 and for the years ended March 31, 2021, March 31, 2020 and March 31, 2019 (enclosed as Annexure V); and
  - (f) Statement of Adjustments to Audited Special Purpose Interim Consolidated Financial Statements as at and for the three months period ended June 30, 2021 and Audited Consolidated Financial Statements as at and for the years ended March 31, 2021, March 31, 2020 and March 31, 2019 (enclosed as Annexure VI);

(hereinafter together referred to as the "Restated Consolidated Financial Information"), prepared by the Management of the Company in connection with the Proposed Initial Public Offering of Equity Shares of the Company (the "IPO" or "Issue") in accordance with the requirements of:

- i. Section 26 of the Companies Act, 2013 (the "Act") as amended from time to time;
- ii. Paragraph (A) of Clause 11 (I) of Part A of Schedule VI of the Securities and Exchange Board of India (Issue of Capital and Disclosure Requirements) Regulations, 2018, as amended to date (the "SEBI ICDR Regulations") issued by the Securities and Exchange Board of India (the "SEBI"); and
- iii. the Guidance Note on Reports in Company Prospectuses (Revised 2019) issued by the Institute of Chartered Accountants of India ("ICAI"), as amended from time to time (the "Guidance Note").

Price Waterhouse & Co Bangalore LLP, Plot No. 56 & 57, Block DN, Sector V, Salt Lake, Kolkata - 700 091, India  
T: +91 (33) 44001111 / 44662000, F: +91 (33) 44043065

Registered office and Head office: 5th Floor, Tower D, The Millenia, 1 & 2 Murphy Road, Ulsoor, Bangalore - 560 008

Price Waterhouse & Co Bangalore LLP (LLP IN: AAC-6284) is registered as a Limited Liability Partnership (LLP). Price Waterhouse & Co., Bangalore has converted from partnership firm to an LLP effective August 25, 2014. Its registration number with ICAI after said conversion as LLP is 007567S/S200012 (registration number before conversion was 007567S)

# Price Waterhouse & Co Bangalore LLP

## Chartered Accountants

The said Restated Consolidated Financial Information has been approved by the Board of Directors of the Company at their meeting held on November 10, 2021 for the purpose of inclusion in the Red Herring Prospectus ("RHP") and the Prospectus (the "Prospectus") and has been initialed by us for identification purposes only.

### **Management's Responsibility for the Restated Consolidated Financial Information**

3. The preparation of the Restated Consolidated Financial Information, for the purpose of inclusion in the RHP and the Prospectus to be filed with Securities and Exchange Board of India ("SEBI"), BSE Limited ("BSE"), National Stock Exchange of India Limited ("NSE") and the Registrar of Companies, West Bengal at Kolkata (the "ROC") in connection with the proposed IPO, is the responsibility of the Management of the Company. The Restated Consolidated Financial Information have been prepared by the Management of the Company on the basis of preparation stated in Note 2.1 to the Restated Consolidated Financial Information in Annexure V. The Management's responsibility includes designing, implementing and maintaining internal control relevant to the preparation and presentation of the Restated Consolidated Financial Information. The Management is also responsible for identifying and ensuring that the Company, its subsidiaries and its joint venture comply with the Act, SEBI ICDR Regulations and the Guidance Note.

### **Auditor's Responsibilities**

4. Our work has been carried out considering the concepts of test checks and materiality to obtain reasonable assurance based on verification of evidence supporting the Restated Consolidated Financial Information in accordance with the Guidance Note on Reports in Company Prospectuses (Revised 2019) and other applicable authoritative pronouncements issued by the Institute of Chartered Accountants of India and pursuant to the requirements of Section 26 of the Act, and the SEBI ICDR Regulations. Our work was performed solely to assist you in meeting your responsibilities in relation to your compliance with the Act, the SEBI ICDR Regulations and the Guidance Note in connection with the Issue.
5. The Guidance Note requires that we comply with the ethical requirements of the Code of Ethics issued by the Institute of Chartered Accountants of India.
6. Our examination of the Restated Consolidated Financial Information has not been carried out in accordance with the auditing standards generally accepted in the United States of America, standards of the Public Company Accounting Oversight Board and accordingly should not be relied upon by any one as if it had been carried out in accordance with those standards or any other standards besides the standards referred to in this report.
7. The Restated Consolidated Financial Information, expressed in Indian Rupees in millions (INR Millions), has been prepared by the Company's Management from:
  - (a) the Audited Special Purpose Interim Consolidated Financial Statements of the Group and its joint venture as at and for the three months period ended June 30, 2021 prepared in accordance with Indian Accounting Standard (Ind AS) 34 "Interim Financial Reporting", specified under section 133 of the Act read with Companies (Indian Accounting Standards) Rules 2015, as amended, and other accounting principles generally accepted in India, except for inclusion of comparative information, as those are not being given in the Restated Consolidated Financial Information pursuant to the exemption available to the Issuer under Paragraph (A)(i) of Clause 11 (I) of Part A of Schedule VI of the SEBI ICDR Regulations, which have been approved by the Board of Directors at their meeting held on November 10, 2021.



# Price Waterhouse & Co Bangalore LLP

## Chartered Accountants

- (b) the Audited Consolidated Financial Statements of the Group and its joint venture as at and for the years ended March 31, 2021, March 31, 2020 and March 31, 2019 prepared in accordance with the Indian Accounting Standards (referred to as “Ind AS”) as prescribed under Section 133 of the Act read with Companies (Indian Accounting Standards) Rules 2015, as amended, and other accounting principles generally accepted in India, which have been approved by the Board of Directors at their meeting held on August 3, 2021, September 18, 2020 and August 13, 2019, respectively.
8. For the purpose of our examination, we have relied on:
- (a) the Auditor’s report issued by us dated November 10, 2021 on the special purpose interim consolidated financial statements of the Group and its joint venture as at and for the three months period ended June 30, 2021 as referred in paragraph 7(a) above, on which we issued a modified opinion vide our report dated November 10, 2021, modified with regard to non-furnishing of comparative financial information, which are not being presented in the Restated Consolidated Financial Information pursuant to the exemption of not presenting the comparative financial information availed by the Issuer as per clause Paragraph (A)(i) of Clause 11 (I) of Part A of Schedule VI of SEBI ICDR Regulations;
- (b) the Auditor’s reports issued by us on the consolidated financial statements as at and for the years ended March 31, 2021, March 31, 2020 and March 31, 2019 as referred in Paragraph 7(b) above, on which we issued an unmodified opinion vide our reports dated August 3, 2021, September 18, 2020 and August 13, 2019, respectively; and
- (c) the Auditor’s reports for Tega Industries Chile SpA, a subsidiary of the Company:
- i) issued by the erstwhile auditors on its consolidated financial statements as at and for the year ended March 31, 2019 and consolidated financial information as at and for the year ended March 31, 2020, on which they issued an unmodified audit opinion vide their reports dated June 26, 2019 and August 26, 2020, respectively. We have examined:
- a. the Ind AS adjustments and the adjustments for restatements to be done in accordance with SEBI ICDR Regulations and the Guidance Note, made to the Audited Consolidated Financial Statements of the subsidiary as at and for the year ended March 31, 2019, as required for the purposes of Restated Consolidated Financial Information; and
- b. the adjustments made to the Audited Consolidated Financial Information of the subsidiary as at and for the year ended March 31, 2020, for restatements to be done in accordance with SEBI ICDR Regulations and the Guidance Note, as required for the purposes of Restated Consolidated Financial Information.
- ii) issued by the current auditors on consolidated specific financial information as at and for the years ended March 31, 2019 and March 31, 2020, on which they issued an unmodified audit opinion vide their report dated November 9, 2021.
9. We have not audited any financial statements or examined any restated consolidated financial information of the Group and its joint venture as of any date or for any period subsequent to June 30, 2021. Accordingly, we do not express any opinion on the financial position, results or cash flows of the Group and its joint venture as of any date or for any period subsequent to June 30, 2021.

# **Price Waterhouse & Co Bangalore LLP**

## **Chartered Accountants**

### **Opinion**

10. Based on our examination and according to the information and explanations given to us and also as per the reliance placed on the examination report submitted by the other auditors for the respective period / years as referred to in paragraph 16, we report that the Restated Consolidated Financial Information:
  - a. have been prepared in accordance with the Act, the SEBI ICDR Regulations and the Guidance Note;
  - b. have been prepared after incorporating adjustments in respect of changes in the accounting policies, material errors and regrouping / reclassifications, as may be applicable, retrospectively (as disclosed in Annexure VI to the Restated Consolidated Financial Information) to reflect the same accounting treatment as per the accounting policies as at and for the three months period ended June 30, 2021, for all the reporting periods; and
  - c. do not require any adjustments for the matter giving rise to modification in our auditor's report on the special purpose interim consolidated financial statements as at and for the three months period ended June 30, 2021, as mentioned in paragraph 8(a) above, and there are no qualifications in our auditor's reports on the consolidated financial statements as at and for the years ended March 31, 2021, March 31, 2020 and March 31, 2019, as mentioned in paragraph 8(b) above, which require any adjustments.
11. The Restated Consolidated Financial Information do not reflect the effects of events that occurred subsequent to the respective dates of the reports on the audited special purpose interim consolidated financial statements and the audited consolidated financial statements mentioned in paragraph 8(a) and 8(b) above respectively.
12. This report should not in any way be construed as a re-issuance or re-dating of any of the audit reports issued by us or other auditors on the Special Purpose Interim Consolidated Financial Statements and on the Consolidated Financial Statements of the Group and its joint venture, or any components included in those financial statements as may be applicable, for the reporting periods.
13. We have no responsibility to update our report for events and circumstances occurring after the date of the report.

# Price Waterhouse & Co Bangalore LLP

## Chartered Accountants

### Emphasis of Matter

14. We draw your attention to the following:

- (i) Note 49 to the Restated Consolidated Financial Information regarding the accounting treatment of certain equity shares and compulsorily convertible participatory preference shares ("CCPP") presented as equity share capital and preference share capital respectively and the premium thereon presented under securities premium account in the Restated Consolidated Financial Information, in accordance with the requirements of the Companies Act, 2013. Such presentation and measurement is not in accordance with Ind AS 32 'Financial Instruments: Presentation' and Ind AS 109 'Financial Instruments' which requires the presentation of these equity shares, CCPP and the securities premium as a financial liability in its entirety, given the obligation on the Holding Company to buy-back these equity shares and CCPP from the holders and subsequent changes in measurement of financial liability to be recognised in the Restated Consolidated Statement of Profit and Loss. Further, the relevant disclosures required under Ind AS 107 'Financial Instruments: Disclosures' and under Ind AS 1 'Presentation of financial statements' for these equity shares and CCPP have not been made in the Restated Consolidated Financial Information in view of the reasons set out in the aforesaid Note. Our opinion is not modified in respect of this matter.

Note 49 referred above corresponds to Note 47 in the Special Purpose Interim Consolidated Financial Statements for the three months period ended June 30, 2021 and Note 49 in the Consolidated Financial Statements for the year ended March 31, 2021. The above emphasis of matter paragraph has also been included in the auditor's reports dated November 10, 2021 and August 3, 2021 issued by us on the said Special Purpose Interim Consolidated Financial Statements of the Company for the three months period ended June 30, 2021 and Consolidated Financial Statements of the Company for the year ended March 31, 2021 respectively.

- (ii) The auditor's report issued by us dated November 10, 2021 on the Special Purpose Interim Consolidated Financial Statements of the Group and its Joint Venture as at and for the three months period ended June 30, 2021 included the following Emphasis of Matter paragraph, which has been reproduced below:

"We draw your attention to Note 51 (d) to the Special Purpose Interim Consolidated Financial Statements regarding non-settlement of foreign currency payables as at June 30, 2021 amounting to INR 5.84 million and INR 0.47 million outstanding beyond the time period permitted under the Master Direction on Import of Goods and Services vide FED Master Direction No. 17/ 2016-17 dated January 1, 2016 (as amended), issued by the Reserve Bank of India (RBI), with respect to Merchanting Trade Transaction (MTT) and other import dues respectively. The holding company has submitted application to AD bank seeking RBI approval for extension of time for making payment for aforesaid foreign currency payables other than amount outstanding with respect to MTT, for which approval for making payment has been sought. Our opinion is not modified in respect of this matter."

Note 51 (d) referred above corresponds to Note 53 (d) in Annexure V in the Restated Consolidated Financial Information.

# Price Waterhouse & Co Bangalore LLP

## Chartered Accountants

- (iii) The auditor's report issued by us dated September 18, 2020 on the Consolidated Financial Statements of the Group and its joint venture as at and for the year ended March 31, 2020 included the following Emphasis of Matter paragraph, which has been reproduced below (also refer Note 48 to the Restated Consolidated Financial Information in Annexure V):

"We draw your attention to emphasis of matter paragraph included in the Audit Report on the Consolidated Financial Statements of Tega Industries Chile SpA, a stepdown subsidiary of the Holding Company issued by an independent firm of Chartered Accountants vide its report dated August 26, 2020.

"As of March 31, 2020, the Parent Company presents a deferred tax asset for TH\$ 2,273,885 arising from accumulated tax losses. Its recoverability will depend on compliance with the respective business plan prepared by Management and approved by the Board of Directors of the Company, which is described in Note 21.

As described in Note 26 to the accompanying consolidated financial statements, the Company has recorded negative working capital for TH\$ 1,840,539 (TH\$ 4,567,385 in 2019). Our opinion is not modified with respect this matter".

Note 21 and 26 above has been reproduced by the Management vide Note 47 in the notes to the consolidated financial statements. The Parent Company mentioned above is Tega Industries Chile SpA. Our opinion is not modified in respect of this matter."

- (iv) The auditor's report issued by us dated August 13, 2019 on the Consolidated Financial Statements of the Group and its joint venture as at and for the year ended March 31, 2019 included the following Emphasis of Matter paragraph, which has been reproduced below (also refer Note 48 to the Restated Consolidated Financial Information in Annexure V):

"We draw your attention to the emphasis of matter paragraph included in the Audit Report on the Consolidated Financial Statements of Tega Industries Chile, SPA, a subsidiary of the Holding Company issued by an independent firm of Chartered Accountants vide its report dated June 26, 2019.

"The accompanying financial statements have been prepared assuming that the Company will continue as a going concern. As described in Note No. 18 to the accompanying consolidated financial statements, the Company has recorded negative working capital for M\$ 4,567,385 (M\$ 5,829,639 in 2018), and presents equity deficit in both periods, which introduces a significant doubt about the ability of the Company to continue as a going concern. Management's plan on this matter is also described in Note No. 18. The accompanying Consolidated Financial Statements include no adjustment that might lead to the resolution of the uncertainty expressed above."

Note 18 referred to above have been reproduced by the Management vide Note 50 in the notes to the Consolidated Financial Statements. Our opinion is not modified in respect of this matter."

# Price Waterhouse & Co Bangalore LLP

## Chartered Accountants

### Other Matter

15. As indicated in our audit reports referred in paragraph 8(a) and 8(b) above:

- (a) We did not audit the interim financial information of certain subsidiaries located outside India as of and for the three month period ended June 30, 2021 and financial information of certain subsidiaries located outside India as of and for the years ended March 31, 2021 and March 31, 2020 whose share of total assets, net assets, total revenue, total comprehensive income (comprising of profit / (loss) and other comprehensive income), net cash inflows / (outflows) included in the special purpose interim consolidated financial statements and consolidated financial statements respectively, for the relevant period / years is tabulated in Table A below, which have been audited by other auditors (Refer Table B below), and whose reports have been furnished to us by the Company's management and our opinion on the special purpose interim consolidated financial statements and consolidated financial statements, insofar as it relates to the amounts and disclosures included in respect of these subsidiaries, is based solely on the reports of the other auditors.
- (b) We did not audit the financial statements of certain subsidiaries located outside India as of and for the year ended March 31, 2019 which constitutes total assets, net assets, total revenue, total comprehensive income (comprising of profit / (loss) and other comprehensive income) and net cash inflows / (outflows), included in the consolidated financial statements, for the relevant year is tabulated in Table A below. These financial statements have been prepared in accordance with accounting principles generally accepted in their respective countries and have been audited by other auditors (Refer Table B below), under generally accepted auditing standards applicable in their respective countries. The Company's management has converted the financial statements of such subsidiaries located outside India from the accounting principles generally accepted in their respective countries to the accounting principles generally accepted in India. We have audited these conversion adjustments made by the Company's management. Our opinion insofar as it relates to the balances and affairs of such subsidiaries located outside India, is based on the report of the other auditors and conversion adjustments prepared by the management of the Company are audited by us.
- (c) The Consolidated Financial Statements also include the Group's share of total comprehensive income (comprising of profit and other comprehensive income) for the year ended March 31, 2019 (Refer Table A below), as considered in the Consolidated Financial Statements, in respect of one Joint Venture, whose financial statements have not been audited by us. These financial statements have been audited by other auditor (Refer Table B below), whose report has been furnished to us by the Management, and our opinion on the Consolidated Financial Statements insofar as it relates to the amounts and disclosures included in respect of the Joint venture is based solely on the report of the other auditor.

**Price Waterhouse & Co Bangalore LLP**  
Chartered Accountants

**Table A**

Particulars	As at and for the three months period ended June 30, 2021	As at and for the year ended March 31, 2021	As at and for the year ended March 31, 2020	As at and for the year ended March 31, 2019
Number of Subsidiaries (numbers)	11	11	11	12
Total Assets (INR Million)	8,150.34	8,188.58	6,401.14	5,556.04
Net Assets (INR Million)	700.98	761.26	(1,522.35)	(1,604.39)
Total Revenue (INR Million)	1,000.52	7,045.65	4,765.92	4,205.27
Total Comprehensive Income (INR Million)	(95.56)	2,166.86	270.25	(334.83)
Net cash inflows / (outflows) (INR Million)	144.28	162.20	126.52	(24.96)
Number of Joint Venture (numbers)	-	-	-	1
Share of profit (INR millions)	-	-	-	18.18
Share of other comprehensive income (INR Millions)	-	-	-	(0.75)

# Price Waterhouse & Co Bangalore LLP

## Chartered Accountants

**Table B**

Name of Entity	Country of Incorporation	Relationship	Auditor	Audit period
Tega Industries, Inc.	USA	Subsidiary	R&A CPAs	Three months period ended June 30, 2021, FY 2020-2021, FY 2019-2020 and FY 2018-2019
Tega Industries Australia Pty. Ltd.	Australia	Subsidiary	Goenka Suresh & Associates	Three months period ended June 30, 2021, FY 2020-2021, FY 2019-2020 and FY 2018-2019
Tega Investments Limited	The Bahamas	Subsidiary	Goenka Suresh & Associates	Three months period ended June 30, 2021, FY 2020-2021, FY 2019-2020 and FY 2018-2019
Tega Industries Canada Inc.	Canada	Subsidiary	Goenka Suresh & Associates	Three months period ended June 30, 2021, FY 2020-2021, FY 2019-2020 and FY 2018-2019
Tega Do Brasil Servicos Tecnicos Ltda	Brazil	Subsidiary	Goenka Suresh & Associates	Three months period ended June 30, 2021, FY 2020-2021, FY 2019-2020 and FY 2018-2019
Tega Holdings Pte Limited	Singapore	Subsidiary	Goenka Suresh & Associates	Three months period ended June 30, 2021, FY 2020-2021, FY 2019-2020 and FY 2018-2019
Tega Scanning Solutions Inc.	Canada	Subsidiary	Goenka Suresh & Associates	FY 2018-2019
Tega Holdings Pty Ltd	Australia	Subsidiary	Goenka Suresh & Associates	Three months period ended June 30, 2021, FY 2020-2021, FY 2019-2020 and FY 2018-2019
Losugen Pty Ltd	Australia	Subsidiary	KPMG	Three months period ended June 30, 2021, FY 2020-2021, FY 2019-2020 and FY 2018-2019
Tega Industries Chile SpA and its Subsidiaries*	Chile	Subsidiary	PricewaterhouseCoopers Consultores Auditores SPA	Three months period ended June 30, 2021, FY 2020-2021
			Surlatina Auditores Ltda.	FY 2019-2020 and FY 2018-2019
Tega Investments South Africa Proprietary Limited	South Africa	Subsidiary	Johan Bam & Partners	Three months period ended June 30, 2021, FY 2020-2021 and FY 2019-2020
			PricewaterhouseCoopers Inc.	FY 2018-2019
Tega Industries Africa Proprietary Limited	South Africa	Subsidiary	PricewaterhouseCoopers Inc.	Three months period ended June 30, 2021, FY 2020-2021, FY 2019-2020 and FY 2018-2019
Hosch Equipment (India) Limited	India	Joint Venture	Chaturvedi & Company	FY 2018-2019

\*including Edoctum S.A. and Edoctum Peru S.A.C.

# Price Waterhouse & Co Bangalore LLP

## Chartered Accountants

Our opinion on the special purpose interim consolidated financial statements and consolidated financial statements is not modified in respect of these matters.

16. We did not examine the restated financial information of certain subsidiaries whose share of total assets, net assets, total revenue, total comprehensive income (comprising of profit / (loss) and other comprehensive income), net cash inflows / (outflows) and group's share of total comprehensive income (comprising of profit and other comprehensive income) in respect of one joint venture included in the Restated Consolidated Financial Information, for the relevant period/years is tabulated in Table C below, which have been examined by other auditors (Refer Table D below) and whose examination reports have been furnished to us by the Company's management and our opinion on the Restated Consolidated Financial Information, insofar as it relates to the amounts and disclosures included in respect of these subsidiaries and joint venture, is based solely on the examination reports of the other auditors:

**Table C**

<b>Particulars</b>	<b>As at and for the three months period ended June 30, 2021</b>	<b>As at and for the year ended March 31, 2021</b>	<b>As at and for the year ended March 31, 2020</b>	<b>As at and for the year ended March 31, 2019</b>
Number of Subsidiaries (numbers)	11	11	10	11
Total Assets (INR Million)	8,150.34	8,188.58	4,927.84	4,627.36
Net Assets (INR Million)	700.98	761.26	(1,543.33)	(1,469.22)
Total Revenue (INR Million)	1,000.52	7,045.65	3,562.66	3,474.82
Total Comprehensive Income (INR Million)	(95.56)	2,166.86	121.45	(25.55)
Net cash inflows / (outflows) (INR Million)	144.28	162.20	42.55	(28.72)
Number of Joint Venture (numbers)	-	-	-	1
Share of profit (INR millions)	-	-	-	18.09
Share of other comprehensive income (INR Millions)	-	-	-	(0.75)



# Price Waterhouse & Co Bangalore LLP

## Chartered Accountants

**Table D**

<b>Name of Entity</b>	<b>Country of Incorporation</b>	<b>Relationship</b>	<b>Auditor</b>	<b>Audit period</b>
Tega Industries, Inc.	USA	Subsidiary	R&A CPAs	Three months period ended June 30, 2021, FY 2020-2021, FY 2019-2020 and FY 2018-2019
Tega Industries Australia Pty. Ltd.	Australia	Subsidiary	Goenka Suresh & Associates	Three months period ended June 30, 2021, FY 2020-2021, FY 2019-2020 and FY 2018-2019
Tega Investments Limited	The Bahamas	Subsidiary	Goenka Suresh & Associates	Three months period ended June 30, 2021, FY 2020-2021, FY 2019-2020 and FY 2018-2019
Tega Industries Canada Inc.	Canada	Subsidiary	Goenka Suresh & Associates	Three months period ended June 30, 2021, FY 2020-2021, FY 2019-2020 and FY 2018-2019
Tega Do Brasil Servicos Tecnicos Ltda	Brazil	Subsidiary	Goenka Suresh & Associates	Three months period ended June 30, 2021, FY 2020-2021, FY 2019-2020 and FY 2018-2019
Tega Holdings Pte Limited	Singapore	Subsidiary	Goenka Suresh & Associates	Three months period ended June 30, 2021, FY 2020-2021, FY 2019-2020 and FY 2018-2019
Tega Scanning Solutions Inc.	Canada	Subsidiary	Goenka Suresh & Associates	FY 2018-2019
Tega Holdings Pty Ltd	Australia	Subsidiary	Goenka Suresh & Associates	Three months period ended June 30, 2021, FY 2020-2021, FY 2019-2020 and FY 2018-2019
Losugen Pty Ltd	Australia	Subsidiary	KPMG	Three months period ended June 30, 2021, FY 2020-2021, FY 2019-2020 and FY 2018-2019
Tega Industries Chile SpA and its Subsidiaries*	Chile	Subsidiary	PricewaterhouseCoopers Consultores Auditores SPA	Three months period ended June 30, 2021, FY 2020-2021
Tega Investments South Africa Proprietary Limited	South Africa	Subsidiary	Johan Bam & Partners	Three months period ended June 30, 2021, FY 2020-2021, FY 2019-2020 and FY 2018-2019
Tega Industries Africa Proprietary Limited	South Africa	Subsidiary	PricewaterhouseCoopers Inc.	Three months period ended June 30, 2021, FY 2020-2021, FY 2019-2020 and FY 2018-2019
Hosch Equipment (India) Limited	India	Joint Venture	Chaturvedi & Company	FY 2018-2019

\* including Edoctum S.A. and Edoctum Peru S.A.C.

# **Price Waterhouse & Co Bangalore LLP**

## **Chartered Accountants**

These Other Auditors of the subsidiaries and joint venture, as mentioned above, have confirmed to us that the Restated Standalone / Consolidated Financial Information, as applicable, of the components have been prepared in accordance with the Act, SEBI ICDR Regulations and the Guidance Note or have confirmed they have performed procedures based on instructions issued by us, which in turn are in compliance with the Act, SEBI ICDR Regulations and the Guidance Note, as applicable, and have issued an unmodified opinion on the respective Restated Standalone / Consolidated Financial Information, as applicable, of the components.

### **Restriction on Use**

17. This report is addressed to and is provided to enable the Board of Directors of the Company to include this report in the RHP and the Prospectus, prepared in connection with the proposed Initial Public Offering of Equity Shares of the Company, to be filed by the Company with the Securities and Exchange Board of India, BSE Limited, National Stock Exchange of India Limited and the Registrar of Companies, West Bengal at Kolkata in connection with the proposed IPO. Our report should not be used, referred to, or distributed for any other purpose except with our prior consent in writing. Accordingly, we do not accept or assume any liability or any duty of care for any other purpose or to any other person to whom this report is shown or into whose hands it may come without our prior consent in writing.

For Price Waterhouse & Co Bangalore LLP  
Firm Registration Number: 007567S/S-200012  
Chartered Accountants

Avijit Mukerji  
Partner  
Membership Number: 056155  
UDIN: 21056155AAAACJ3776

Place : Kolkata  
Date : November 10, 2021

Particulars	Annexure V Note	30 June 2021	31 March 2021	31 March 2020	31 March 2019
<b>ASSETS</b>					
<b>Non-current assets</b>					
Property, plant and equipment	3(a)	1,693.12	1,691.96	1,691.49	1,852.56
Right-of-Use Assets	3(b)	607.54	591.01	405.86	385.85
Capital work in progress	3(c)	71.04	68.59	62.22	16.42
Investment property	4	40.56	38.49	33.01	37.21
Goodwill	5	633.92	632.82	523.64	557.46
Other intangible assets	3(d)	18.09	7.13	5.34	7.43
Intangible assets under development	3(e)	-	-	23.93	23.93
Investments accounted for using the equity method	43(d)	275.33	269.22	244.66	234.64
Financial assets					
(i) Investments	6	-	181.85	166.58	151.39
(ii) Other financial assets	7	100.38	103.01	127.28	59.21
Non-current tax assets (net)	8	105.41	101.82	79.83	84.97
Deferred tax assets (net)	9	269.74	256.28	307.81	90.24
Other non-current assets	10	24.25	14.06	8.94	22.57
<b>Total non-current assets</b>		<b>3,839.38</b>	<b>3,956.24</b>	<b>3,680.59</b>	<b>3,523.88</b>
<b>Current assets</b>					
Inventories	11	2,078.66	1,586.31	1,326.30	1,210.58
Financial assets					
(i) Investments	12	1,878.98	1,561.92	1,166.63	382.15
(ii) Trade receivables and contract assets	13	1,697.76	2,208.64	1,852.18	2,103.24
(iii) Cash and cash equivalents	14	645.77	478.70	368.63	192.64
(iv) Other bank balances	15	9.80	5.40	0.48	4.38
(v) Other financial assets	16	52.07	42.27	30.98	44.70
Current tax assets (net)	17	7.28	15.49	30.54	13.14
Other current assets	18	352.02	328.42	416.82	427.97
<b>Total current assets</b>		<b>6,722.34</b>	<b>6,227.15</b>	<b>5,192.56</b>	<b>4,378.80</b>
<b>Total assets</b>		<b>10,561.72</b>	<b>10,183.39</b>	<b>8,873.15</b>	<b>7,902.68</b>
<b>EQUITY AND LIABILITIES</b>					
<b>Equity</b>					
Equity share capital	19A	576.01	576.01	576.01	576.01
Preference share capital	19B	86.92	86.92	86.92	86.92
Other equity	19C	5,648.59	5,474.29	3,961.96	3,348.12
<b>Equity attributable to the owners of the company</b>		<b>6,311.52</b>	<b>6,137.22</b>	<b>4,624.89</b>	<b>4,011.05</b>
<b>Equity attributable to the owners of the non controlling interest</b>		<b>0.00<sup>^</sup></b>	<b>0.00<sup>^</sup></b>	<b>0.00<sup>^</sup></b>	<b>0.00<sup>^</sup></b>
<b>Total equity</b>		<b>6,311.52</b>	<b>6,137.22</b>	<b>4,624.89</b>	<b>4,011.05</b>
<b>Liabilities</b>					
<b>Non-current liabilities</b>					
Financial liabilities					
(i) Borrowings	20	816.85	862.10	951.07	597.33
(ii) Lease Liabilities	3(b)	261.89	237.81	247.89	243.63
(iii) Other financial liabilities	21	82.66	89.23	133.07	33.74
Deferred tax liabilities (net)	22	74.81	87.61	67.42	51.42
<b>Total non-current liabilities</b>		<b>1,236.21</b>	<b>1,276.75</b>	<b>1,399.45</b>	<b>926.12</b>
<b>Current liabilities</b>					
Financial liabilities					
(i) Borrowings	23	1,025.53	1,015.92	1,488.27	1,529.57
(ii) Lease Liabilities	3(b)	75.57	80.89	92.81	64.56
(iii) Trade payables					
(a) Total outstanding dues of micro and small enterprises	24	38.26	42.20	32.00	33.58
(b) Total outstanding dues of creditors other than micro and small enterprises	24	1,136.18	944.90	620.96	773.25
(iv) Other financial liabilities	25	122.34	126.37	156.17	127.58
Provisions	26	169.44	146.37	108.66	119.49
Current tax liabilities (net)	27	109.79	96.53	15.44	43.70
Other current liabilities	28	336.88	316.24	334.50	273.78
<b>Total current liabilities</b>		<b>3,013.99</b>	<b>2,769.42</b>	<b>2,848.81</b>	<b>2,965.51</b>
<b>Total liabilities</b>		<b>4,250.20</b>	<b>4,046.17</b>	<b>4,248.26</b>	<b>3,891.63</b>
<b>Total equity and liabilities</b>		<b>10,561.72</b>	<b>10,183.39</b>	<b>8,873.15</b>	<b>7,902.68</b>

<sup>^</sup>Amount is below the rounding off norm adopted by the Group

The above Restated Consolidated Statement of Assets and Liabilities should be read in conjunction with Notes to Restated Consolidated Financial Information appearing in Annexure - V and Statement of Adjustments to Audited Special Purpose Interim Consolidated Financial Statements as at and for the three months period ended 30 June 2021 and Audited Consolidated Financial Statements as at and for the years ended 31 March 2021, 31 March 2020 and 31 March 2019 appearing in Annexure - VI.

This is the Restated Consolidated Statement of Assets and Liabilities referred to in our report of even date

For Price Waterhouse & Co Bangalore LLP  
Firm Registration Number: 007567S/S-200012  
Chartered Accountants

For and on behalf of Board of Directors

Avijit Mukerji  
Partner  
Membership Number: 056155

Madan Mohan Mohanka  
Chairman  
DIN: 00049388

Mehul Mohanka  
Managing Director  
DIN: 00052134

Sudipta Bhowal  
Company Secretary

Manoj Kumar Agarwal  
Chief Financial Officer

Place : Kolkata  
Date : 10 November 2021

Place : Kolkata  
Date : 10 November 2021

(All amounts in INR million, unless otherwise stated)

Particulars	Annexure V Note	Three months period ended 30 June 2021	Year ended 31 March 2021	Year ended 31 March 2020	Year ended 31 March 2019
Revenue from operations	29	1,732.07	8,055.22	6,848.47	6,337.57
Other income	30	61.79	511.62	106.95	92.56
<b>Total income</b>		<b>1,793.86</b>	<b>8,566.84</b>	<b>6,955.42</b>	<b>6,430.13</b>
<b>Expenses</b>					
Cost of materials consumed	31	764.32	3,282.36	2,847.43	2,650.29
Changes in inventories of finished goods and work-in-progress	32	(78.85)	(44.46)	(109.07)	(76.46)
Employee benefits expense	33	350.25	1,226.70	1,153.34	1,113.91
Finance costs	34	36.13	172.78	214.39	236.02
Depreciation and amortisation expenses	35	105.00	401.80	383.55	377.55
Other expenses	36	461.34	1,715.82	1,891.44	1,682.36
<b>Total expenses</b>		<b>1,638.19</b>	<b>6,755.00</b>	<b>6,381.08</b>	<b>5,983.67</b>
<b>Restated profit before share of restated net profit of joint venture accounted for using equity method and tax</b>		<b>155.67</b>	<b>1,811.84</b>	<b>574.34</b>	<b>446.46</b>
<b>Share of restated net profit of joint venture accounted for using the equity method</b>	43(d)	<b>6.16</b>	<b>26.78</b>	<b>18.09</b>	<b>18.09</b>
<b>Restated profit before tax</b>		<b>161.83</b>	<b>1,838.62</b>	<b>592.43</b>	<b>464.55</b>
Income tax expense					
- Current tax	37	69.67	372.81	154.89	155.96
- Deferred tax	37	(26.66)	101.76	(217.50)	(18.11)
<b>Total tax expense/ (credit)</b>		<b>43.01</b>	<b>474.57</b>	<b>(62.61)</b>	<b>137.85</b>
<b>Restated total profit for the period/ year (A)</b>		<b>118.82</b>	<b>1,364.05</b>	<b>655.04</b>	<b>326.70</b>
<b>Restated other comprehensive income/ (loss)</b>					
<i>Items that will not be reclassified to profit or loss</i>					
(a) Remeasurement gain/ (loss) on post employment defined benefit plans		(2.40)	3.11	(6.36)	(4.87)
(b) Income tax related to above		0.60	(0.78)	2.22	1.70
(c) Share of restated other comprehensive income/ (loss) of joint venture accounted using the equity method		(0.05)	0.03	(0.02)	(0.75)
<i>Items that will be reclassified to profit or loss</i>					
(a) Exchange differences on translation of foreign operations		57.33	138.27	(45.11)	(84.49)
<b>Restated other comprehensive income/ (loss) for the period/ year, net of tax (B)</b>		<b>55.48</b>	<b>140.63</b>	<b>(49.27)</b>	<b>(88.41)</b>
<b>Restated total comprehensive income for the period/ year (A+B)</b>		<b>174.30</b>	<b>1,504.68</b>	<b>605.77</b>	<b>238.29</b>
Restated profit is attributable to:					
Owners of Tega Industries Limited		118.82	1,364.05	655.04	326.28
Non- Controlling interests		0.00 <sup>^</sup>	0.00 <sup>^</sup>	0.00 <sup>^</sup>	0.42
		<b>118.82</b>	<b>1,364.05</b>	<b>655.04</b>	<b>326.70</b>
Restated other comprehensive income/ (loss) is attributable to:					
Owners of Tega Industries Limited		55.48	140.63	(49.27)	(88.41)
Non- Controlling interests		0.00 <sup>^</sup>	0.00 <sup>^</sup>	0.00 <sup>^</sup>	-
		<b>55.48</b>	<b>140.63</b>	<b>(49.27)</b>	<b>(88.41)</b>
Restated total comprehensive income is attributable to:					
Owners of Tega Industries Limited		174.30	1,504.68	605.77	237.87
Non- Controlling interests		0.00 <sup>^</sup>	0.00 <sup>^</sup>	0.00 <sup>^</sup>	0.42
		<b>174.30</b>	<b>1,504.68</b>	<b>605.77</b>	<b>238.29</b>
<b>Restated earnings per equity share: [Nominal Value Per Share INR 10/-]</b>					
Basic	45	2.10	24.10	11.57	5.76
Diluted	45	1.78	20.48	9.84	4.90

<sup>^</sup>Amount is below the rounding off norm adopted by the Group

The above Restated Consolidated Statement of Profit and Loss should be read in conjunction with Notes to Restated Consolidated Financial Information appearing in Annexure - V and Statement of Adjustments to Audited Special Purpose Interim Consolidated Financial Statements as at and for the three months period ended 30 June 2021 and Audited Consolidated Financial Statements as at and for the years ended 31 March 2021, 31 March 2020 and 31 March 2019 appearing in Annexure - VI.

This is the Restated Consolidated Statement of Profit and Loss referred to in our report of even date

For Price Waterhouse & Co Bangalore LLP  
Firm Registration Number: 007567S/S-200012  
Chartered Accountants

For and on behalf of Board of Directors

Avijit Mukerji  
Partner  
Membership Number: 056155

Madan Mohan Mohanka  
Chairman  
DIN: 00049388

Mehul Mohanka  
Managing Director  
DIN: 00052134

Sudipta Bhowal  
Company Secretary

Manoj Kumar Agarwal  
Chief Financial Officer

Place : Kolkata  
Date : 10 November 2021

Place : Kolkata  
Date : 10 November 2021

**A. Equity share capital**

Description	Annexure V Note	Amount
<b>As at 1 April 2018</b>		576.01
Changes during the year		-
<b>As at 31 March 2019</b>	19A	576.01
Changes during the year		-
<b>As at 31 March 2020</b>	19A	576.01
Changes during the year		-
<b>As at 31 March 2021</b>	19A	576.01
Changes during the period		-
<b>As at 30 June 2021</b>	19A	576.01

**B. Preference share capital**

Description	Annexure V Note	Amount
<b>As at 1 April 2018</b>		86.92
Changes during the year		-
<b>As at 31 March 2019</b>	19B	86.92
Changes during the year		-
<b>As at 31 March 2020</b>	19B	86.92
Changes during the year		-
<b>As at 31 March 2021</b>	19B	86.92
Changes during the period		-
<b>As at 30 June 2021</b>	19B	86.92

**C. Other equity**

Description	Annexure V Note	Reserve and surplus			Other reserves	Share options outstanding account	Total other equity	Non-controlling interests	Total
		Securities premium	General reserve	Retained earning	Foreign Currency Translation Reserve				
<b>Balance as at 1 April 2018</b>	19C	902.10	337.98	1,855.25	11.36	0.48	3,107.17	1.24	3,108.41
Restated profit for the year		-	-	326.28	-	-	326.28	0.42	326.70
Restated Other Comprehensive (loss) [net of tax]		-	-	(3.92)	(84.49)	-	(88.41)	-	(88.41)
Adjustment arising on disposal of a subsidiary		-	-	3.54	-	-	3.54	(1.66)	1.88
<b>Transactions with owners in their capacity as owners:</b>									
Dividend on preference shares	41b	-	-	(0.00 <sup>^</sup> )	-	-	(0.00 <sup>^</sup> )	-	(0.00 <sup>^</sup> )
Tax on dividend on preference shares	41b	-	-	(0.00 <sup>^</sup> )	-	-	(0.00 <sup>^</sup> )	-	(0.00 <sup>^</sup> )
Tax on dividend from joint venture	19C	-	-	(0.46)	-	-	(0.46)	-	(0.46)
<b>Balance as at 31 March 2019</b>		902.10	337.98	2,180.69	(73.13)	0.48	3,348.12	0.00 <sup>^</sup>	3,348.12
<b>Ind AS 116 transition adjustment (refer Annexure VI)</b>		-	-	9.66	(0.20)	-	9.46	-	9.46
<b>Balance as at 1 April 2019</b>	19C	902.10	337.98	2,190.35	(73.33)	0.48	3,357.58	0.00 <sup>^</sup>	3,357.58
Restated profit for the year		-	-	655.04	-	-	655.04	0.00 <sup>^</sup>	655.04
Restated Other Comprehensive (loss) [net of tax]		-	-	(4.16)	(45.11)	-	(49.27)	0.00 <sup>^</sup>	(49.27)
<b>Transactions with owners in their capacity as owners:</b>									
Dividend on preference shares	41b	-	-	(0.00 <sup>^</sup> )	-	-	(0.00 <sup>^</sup> )	-	(0.00 <sup>^</sup> )
Tax on dividend from joint venture	19C	-	-	(1.39)	-	-	(1.39)	-	(1.39)
<b>Balance as at 31 March 2020</b>		902.10	337.98	2,839.84	(118.44)	0.48	3,961.96	0.00 <sup>^</sup>	3,961.96

Description	Annexure V Note	Reserve and surplus			Other reserves	Share options outstanding account	Total other equity	Non-controlling interests	Total
		Securities premium	General reserve	Retained earning	Foreign Currency Translation Reserve				
<b>Balance as at 1 April 2020</b>	<b>19C</b>	<b>902.10</b>	<b>337.98</b>	<b>2,839.84</b>	<b>(118.44)</b>	<b>0.48</b>	<b>3,961.96</b>	<b>0.00<sup>^</sup></b>	<b>3,961.96</b>
Restated profit for the year		-	-	1,364.05	-	-	1,364.05	0.00 <sup>^</sup>	1,364.05
Restated Other Comprehensive income [net of tax]		-	-	2.36	138.27	-	140.63	0.00 <sup>^</sup>	140.63
Transfers within equity		-	-	(3.08)	3.08	-	-	-	-
Other Adjustments		-	-	7.65	-	-	7.65	-	7.65
<b>Transactions with owners in their capacity as owners:</b>									
Dividend on preference shares	41b	-	-	(0.00 <sup>^</sup> )	-	-	(0.00 <sup>^</sup> )	-	(0.00 <sup>^</sup> )
<b>Balance as at 31 March 2021</b>		<b>902.10</b>	<b>337.98</b>	<b>4,210.82</b>	<b>22.91</b>	<b>0.48</b>	<b>5,474.29</b>	<b>0.00<sup>^</sup></b>	<b>5,474.29</b>
<b>Balance as at 1 April 2021</b>	<b>19C</b>	<b>902.10</b>	<b>337.98</b>	<b>4,210.82</b>	<b>22.91</b>	<b>0.48</b>	<b>5,474.29</b>	<b>0.00<sup>^</sup></b>	<b>5,474.29</b>
Restated profit for the period		-	-	118.82	-	-	118.82	0.00 <sup>^</sup>	118.82
Restated Other Comprehensive income [net of tax]		-	-	(1.85)	57.33	-	55.48	-	55.48
<b>Balance as at 30 June 2021</b>		<b>902.10</b>	<b>337.98</b>	<b>4,327.79</b>	<b>80.24</b>	<b>0.48</b>	<b>5,648.59</b>	<b>0.00<sup>^</sup></b>	<b>5,648.59</b>

<sup>^</sup>Amount is below the rounding off norm adopted by the Group

The above Restated Consolidated Statement of Changes in Equity should be read in conjunction with Notes to the Restated Consolidated Financial Information appearing in Annexure - V and Statement of Adjustments to the Audited Special Purpose Interim Consolidated Financial Statements as at and for the three months period ended 30 June 2021 and Audited Consolidated Financial Statements as at and for the years ended 31 March 2021, 31 March 2020 and 31 March 2019 appearing in Annexure - VI.

This is the Restated Consolidated Statement of Changes in Equity referred to in our report of even date.

**For Price Waterhouse & Co Bangalore LLP**

Firm Registration Number: 007567S/S-200012

Chartered Accountants

**For and on behalf of Board of Directors**

Avijit Mukerji  
Partner  
Membership Number: 056155

Madan Mohan Mohanka  
Chairman  
DIN: 00049388

Mehul Mohanka  
Managing Director  
DIN: 00052134

Sudipta Bhowal  
Company Secretary

Manoj Kumar Agarwal  
Chief Financial Officer

Place : Kolkata  
Date : 10 November 2021

Place : Kolkata  
Date : 10 November 2021

Particulars	Three months period ended 30 June 2021	Year ended 31 March 2021	Year ended 31 March 2020	Year ended 31 March 2019
<b>A. Cash flow from Operating Activities</b>				
Restated Profit before tax	161.83	1,838.62	592.43	464.55
Adjustments for:				
Depreciation and amortisation expenses	105.00	401.80	383.55	377.55
Finance costs	28.50	138.79	194.78	225.25
Interest income	(1.12)	(4.56)	(4.15)	(4.35)
Allowance for expected credit loss (including bad debts and advances written off)	6.14	57.39	48.72	38.56
Claims/ Liquidating damages	0.47	14.47	2.69	34.38
Net fair value (gain) on investments classified at FVTPL	(21.34)	(78.13)	(37.35)	(21.31)
Mark to market (gain)/ loss on derivative instrument (net)	(8.23)	(61.59)	87.36	(20.86)
Payment on Derivative Settlement (net)	11.49	44.56	23.14	13.33
Liabilities/ Provisions no longer required written back	(0.29)	(12.80)	(53.60)	(19.60)
Net loss/(gain) on sale of property, plant and equipment including intangible assets (including loss on assets scrapped/ written off)	(0.60)	37.28	8.83	14.10
Dividend Income from investments measured at FVTPL	-	(11.81)	(4.45)	(0.87)
Share of restated profit of joint venture accounted for using the equity method	(6.16)	(26.78)	(18.09)	(18.09)
Provision for Warranty Expenses	4.83	23.29	8.99	9.76
Net (gain) on sale of investments classified at FVTPL	(0.81)	(2.50)	(0.25)	(13.49)
Loss on disposal of a subsidiary	-	-	-	3.63
Provision for slow moving/ non- moving and obsolete inventory	(1.02)	52.91	49.46	(8.97)
Other non cash items	(0.06)	(1.39)	-	-
Effect of unrealised exchange differences (net)	11.76	(18.85)	76.68	95.78
<b>Restated operating profit before working capital changes</b>	<b>290.39</b>	<b>2,390.70</b>	<b>1,358.74</b>	<b>1,169.35</b>
<b>Changes in Working Capital:</b>				
(Increase)/ decrease in Non Current/ Current financial and other assets	497.69	(396.65)	430.51	(389.90)
(Increase) in inventories	(491.33)	(312.92)	(165.18)	(100.18)
Increase/ (decrease) in Non Current/ Current financial and other liabilities/ provisions	247.47	324.69	(145.07)	153.70
<b>Cash Generated from Operations</b>	<b>544.22</b>	<b>2,005.82</b>	<b>1,479.00</b>	<b>832.97</b>
Direct Taxes paid (net of refunds)	(51.87)	(303.36)	(195.25)	(146.28)
<b>Net cash generated from operating activities</b>	<b>492.35</b>	<b>1,702.46</b>	<b>1,283.75</b>	<b>686.69</b>
<b>B. Cash flow from Investing Activities</b>				
Purchase of capital assets	(93.11)	(486.12)	(277.99)	(261.57)
Sale of capital assets	1.61	2.27	13.57	7.54
Proceeds from disposal of a subsidiary	-	-	-	7.45
Payment for purchase of investments	(319.98)	(1,659.56)	(1,244.30)	(606.96)
Proceeds from sale of investments	206.93	1,341.46	486.68	711.96
Deposits with bank placed	(2.16)	(111.02)	(202.36)	(325.19)
Deposits with bank matured	-	110.06	199.26	326.45
Interest received	0.95	3.37	5.42	3.86
Dividend received	-	2.25	6.75	2.25
<b>Net cash (used in) investing activities</b>	<b>(205.76)</b>	<b>(797.29)</b>	<b>(1,012.97)</b>	<b>(134.21)</b>
<b>C. Cash flow from Financing Activities</b>				
Proceeds from long term borrowings	-	171.46	697.59	-
Repayment of long term borrowings	(47.75)	(128.36)	(564.18)	(450.27)
Proceeds from/ (repayment of) short term borrowings (net)	(8.27)	(574.03)	45.48	(206.81)
Payment on Derivative Settlement (net)	(11.49)	(44.56)	(23.14)	(13.33)
Finance cost paid	(22.66)	(110.71)	(168.51)	(196.06)
Finance cost paid on account of Lease Liability	(6.54)	(26.52)	(25.71)	(29.23)
Repayment of Lease Liability	(21.88)	(77.32)	(53.56)	(36.42)
Dividends paid	-	(0.00 <sup>^</sup> )	(0.00 <sup>^</sup> )	(0.00 <sup>^</sup> )
Dividend distribution tax paid	-	-	-	(0.00 <sup>^</sup> )
<b>Net cash (used in) financing activities</b>	<b>(118.59)</b>	<b>(790.04)</b>	<b>(92.03)</b>	<b>(932.12)</b>
Net increase in cash and cash equivalents	<b>168.00</b>	<b>115.13</b>	<b>178.75</b>	<b>(379.64)</b>
Cash and cash equivalents at the beginning of the period/ year	478.70	368.63	192.64	576.01
Exchange differences on translation of foreign currency cash & cash equivalent	(0.93)	(5.06)	(2.76)	(4.63)
Cash & cash equivalents at the end of the period/ year	<b>645.77</b>	<b>478.70</b>	<b>368.63</b>	<b>192.64</b>
	<b>30 June 2021</b>	<b>31 March 2021</b>	<b>31 March 2020</b>	<b>31 March 2019</b>
<b>Cash and Cash Equivalents comprise :</b>				
Cash on hand	1.10	1.29	0.98	0.94
Balances with banks on current account	472.90	343.32	225.97	191.63
Balances with banks in deposit account (less than three months maturity)	171.77	134.09	141.68	0.07
	<b>645.77</b>	<b>478.70</b>	<b>368.63</b>	<b>192.64</b>

**Notes:**

- The above Restated Consolidated Statement of Cash Flows has been prepared under the Indirect Method as set out in Ind AS - 7 "Statement of Cash Flows".
- Cash flow from investing activities does not include dividend income on mutual funds which was reinvested in the mutual funds to the tune of INR NIL (31 March 2021: INR 11.81 Mn ; 31 March 2020: INR 4.45 Mn and 31 March 2019: INR 0.87 Mn) being non cash items.
- During the period/ year non-cash transaction from Investing and Financing Activities with respect to acquisition of Right-of-Use Assets with corresponding adjustments to Lease Liabilities INR 37.58 Mn (31 March 2021: INR 24.96 Mn ; 31 March 2020: INR 171.30 Mn and 31 March 2019: INR 14.94 Mn).

<sup>^</sup>Amount is below the rounding off norm adopted by the Group

The above Restated Consolidated Statement of Cash Flows should be read in conjunction with Notes to the Restated Consolidated Financial Information appearing in Annexure - V and Statement of Adjustments to the Audited Special Purpose Interim Consolidated Financial Statements as at and for the three months period ended 30 June 2021 and Audited Consolidated Financial Statements as at and for the years ended 31 March 2021, 31 March 2020 and 31 March 2019 appearing in Annexure - VI.

This is the Restated Consolidated Statement of Cash Flows referred to in our report of even date.

**For Price Waterhouse & Co Bangalore LLP**  
Firm Registration Number: 007567S/S-200012  
Chartered Accountants

**For and on behalf of Board of Directors**

Avijit Mukerji  
Partner  
Membership Number: 056155

Madan Mohan Mohanka  
Chairman  
DIN: 00049388

Mehul Mohanka  
Managing Director  
DIN: 00052134

Sudipta Bhowal  
Company Secretary

Manoj Kumar Agarwal  
Chief Financial Officer

Place : Kolkata  
Date : 10 November 2021

Place : Kolkata  
Date : 10 November 2021

## **1. Corporate Information**

These Restated Consolidated Financial Information comprise the Restated Financial Information of Tega Industries Limited (hereinafter referred to as the "Holding Company" or "Company") and its subsidiaries, (the Holding Company and its subsidiaries together referred to as "the Group"), and its joint venture for the three months period ended 30 June 2021 and for the years ended 31 March 2021, 31 March 2020 and 31 March 2019.

The Group is engaged in the activity of designing, manufacturing and installation of process equipment and accessories to cater the mineral processing, mining, material handling and environment industries.

These Restated Consolidated Financial Information were approved and authorised for issue in accordance with a resolution of the Holding Company's Board of Directors on 10 November 2021.

## **2. Summary of significant accounting policies**

This note provides a list of the significant accounting policies adopted in the preparation of these Restated Consolidated Financial Information. These policies have been consistently applied to all the period/ years presented, unless otherwise stated.

### **2.1 Basis of Preparation**

(i) The restated consolidated financial information of the Group and its joint venture comprises of the Restated Consolidated Statement of Assets and Liabilities as at 30 June 2021, 31 March 2021, 31 March 2020 and 31 March 2019, the Restated Consolidated Statement of Profit and Loss, the Restated Consolidated Statement of Changes in Equity and Restated Consolidated Statement of Cash Flows for the three months period ended 30 June 2021 and for the years ended 31 March 2021, 31 March 2020 and 31 March 2019, Notes to the Restated Consolidated Financial Information and Statement of Adjustments to the Audited Special Purpose Interim Consolidated Financial Statements as at and for the three months period ended 30 June 2021 and Audited Consolidated Financial Statements as at and for the years ended 31 March 2021, 31 March 2020 and 31 March 2019 (collectively, the 'Restated Consolidated Financial Information').

These Restated Consolidated Financial Information have been prepared by the Management of the Group for the purpose of inclusion in the Red Herring Prospectus ("RHP") and Prospectus (the "Prospectus") to be filed by the Company with the Securities and Exchange Board of India, National Stock Exchange of India Limited, BSE Limited and the Registrar of Companies, West Bengal at Kolkata (the "ROC") in connection with proposed Initial Public Offering ("IPO") of its equity shares.

The Restated Consolidated Financial Information, which have been approved by the Board of Directors of the Company, have been prepared in accordance with the requirements of:

- a) Section 26 of the Companies Act, 2013 ("the Act") as amended from time to time;
- b) Paragraph (A) of Clause 11 (I) of Part A of Schedule VI of the Securities and Exchange Board of India (Issue of Capital and Disclosure Requirements) Regulations, 2018, as amended to date (the "SEBI ICDR Regulations") issued by the Securities and Exchange Board of India (the "SEBI"); and
- c) The Guidance Note on Reports in Company Prospectuses (Revised 2019) issued by the Institute of Chartered Accountants of India ("ICAI"), as amended from time to time (the "Guidance Note").

The Restated Consolidated Financial Information have been prepared from:

- a) the Audited Special Purpose Interim Consolidated Financial Statements of the Group and its joint venture as at and for the three months period ended 30 June 2021 prepared in accordance with Indian Accounting Standard (Ind AS) 34 "Interim Financial Reporting", specified under section 133 of the Act read with Companies (Indian Accounting Standards) Rules 2015, as amended, and other accounting principles generally accepted in India, except for inclusion of comparative information, as those are not being given in the Restated Consolidated Financial Information pursuant to the exemption available to the Issuer under Paragraph (A)(i) of Clause 11 (I) of Part A of Schedule VI of the SEBI ICDR Regulations, which have been approved by the Board of Directors at their meeting held on 10 November 2021 on which a modified audit opinion was issued vide audit report dated 10 November 2021.
- b) the Audited Consolidated Financial Statements of the Group and its joint venture as at and for the years ended 31 March 2021, 31 March 2020 and 31 March 2019 which were prepared by the Company in accordance with Indian Accounting Standards ("Ind AS") notified under Section 133 of the Companies Act 2013, read with Companies (Indian Accounting Standards) Rules, 2015 as amended from time to time and other accounting principles generally accepted in India (referred to as "Ind AS"), and were approved by the Board of Directors of the Company at their meetings held on 3 August 2021, 18 September 2020, 13 August 2019 on which an unmodified audit opinion was issued vide audit report dated 3 August 2021, 18 September 2020, 13 August 2019, respectively.

The accounting policies have been consistently applied by the Group and its joint venture in preparation of the Restated Consolidated Financial Information and are consistent with those adopted in the preparation of audited special purpose interim consolidated financial statements for the three months period ended 30 June 2021. These Restated Consolidated Financial Information do not reflect the effects of events that occurred subsequent to the respective dates of auditor's reports on the Audited Special Purpose Interim Consolidated Financial Statements and the Audited Consolidated Financial Statements above.

The Restated Consolidated Financial Information:

- a) have been prepared after incorporating adjustments in respect of changes in the accounting policies, material errors and regrouping/reclassifications, as may be applicable, retrospectively in the years ended 31 March 2021, 31 March 2020 and 31 March 2019 to reflect the same accounting treatment as per the accounting policies and grouping/classifications followed as at and for the three months period ended 30 June 2021.
- b) do not require any adjustment for qualification as there are no qualifications in the underlying audit reports that require adjustment.

All the amounts included in the Restated Consolidated Financial Information are presented in Indian Rupees ('Rupees' or 'Rs.' Or 'INR') and are rounded to the nearest millions (Mn) with two decimal places, except per share data and unless stated otherwise.

The Restated Consolidated Financial Information has been prepared on a historical cost basis, except for:

- Certain financial assets and liabilities measured at fair value (refer accounting policy regarding financial instruments);
- defined benefit plans – plan assets measured at fair value; and
- share-based payments.

### **(ii) Current versus Non Current Classification**

All assets and liabilities have been classified as current or non-current as per the Group's operating cycle and other criteria set out in the Indian Accounting Standards (Ind AS) and Schedule III to the Companies Act, 2013. Based on the nature of products and the time between the acquisition of assets for processing and their realisation in cash and cash equivalents, the Group has ascertained its operating cycle as 12 months for the purpose of current – non-current classification of assets and liabilities.

### **2.2 Use of Estimates**

The preparation of Restated Consolidated Financial Information requires the use of accounting estimates which, by definition, will seldom equal the actual results. Estimates are continually evaluated. They are based on historical experience and other factors, including expectations of future events that may have a financial impact on the group and that are believed to be reasonable under the circumstances.



### 2.3 Principles of consolidation and equity accounting

#### (i) Subsidiaries

Subsidiaries are all entities over which the Group has control. The Group controls an entity when the Group is exposed to, or has right to, variable returns from its involvement with the entity and has the ability to affect those returns through its power to direct the relevant activities of the entity. Subsidiaries are fully consolidated from the date on which control is transferred to the Group. They are deconsolidated from the date that control ceases.

The acquisition method of accounting is used to account for business combinations by the Group.

The Group combines the Restated Consolidated Financial Information of the parent and its subsidiaries line by line adding together like items of assets, liabilities, equity, income and expenses. Intercompany transactions, balances and unrealised gains on transactions between Group companies are eliminated. Unrealised losses are also eliminated unless the transaction provides evidence of an impairment of the transferred asset. Accounting policies of subsidiaries have been changed where necessary to ensure consistency with the policies adopted by the Group. IND AS 12 'Income Tax' applies to temporary differences that arise from the elimination of profits and losses resulting from Intercompany transaction.

Non-controlling interests in the results and equity of subsidiaries are shown separately in the Restated Consolidated Statement of Profit and Loss, Restated Consolidated Statement of Changes in Equity and Restated Consolidated Statement of Assets and Liabilities respectively.

#### (ii) Interest in Joint Ventures accounted for using equity method.

Under Ind AS 111, Joint Arrangements, investments in joint arrangements are classified as either joint operations or joint ventures. The classification depends on the contractual rights and obligations of each investor, rather than the legal structure of the joint arrangement. The group only has investment in joint venture.

Under the equity method of accounting, the investment is initially recognised at cost and adjusted thereafter to recognise the Group's share of the post-acquisition restated profits or losses of the investee in restated profit and loss, and the Group's share of restated other comprehensive income of the investee in restated other comprehensive income. Dividend received or receivable from joint venture is recognised as a reduction in the carrying amount of investment.

When the Group's share of losses in an equity-accounted investment equals or exceeds its interest in the entity, including any other long term receivables, the Group does not recognise further losses, unless it has incurred obligations or made payments on behalf of the other entity.

Unrealised gains on transactions between the Group and its joint venture are eliminated to the extent of the Group's interest in joint venture. Unrealised losses are also eliminated unless the transaction provides evidence of an impairment of the asset transferred. Accounting policies of equity accounted investee are changed where necessary to ensure consistency with the policies adopted by the Group.

### 2.4 Property plant and equipment

Freehold land is carried at historical cost. All other items of property plant and equipment are stated at historical cost net of accumulated depreciation and accumulated impairment losses, if any. Historical cost includes expenditure that is directly attributable to the acquisition of the items.

Subsequent costs are included in the asset's carrying amount or recognised as a separate asset, as appropriate, only when it is probable that future economic benefits associated with the item will flow to the Group and the cost of the item can be measured reliably. The carrying amount of any component accounted for as a separate asset is derecognised when replaced. All other repairs and maintenance are charged to restated consolidated statement of profit and loss during the reporting period in which they are incurred.

An asset's carrying amount is written down immediately to its recoverable amount if the asset's carrying amount is greater than its estimated recoverable amount.

Gains and losses on disposals are determined by comparing proceeds with carrying amount. These are included in the Restated Consolidated Statement of Profit and Loss.

On transition to Ind AS, the Group has elected to continue with the carrying value of its property plant and equipment measured at the previous GAAP and use that carrying value as the deemed cost of property plant and equipment.

#### Depreciation

i) Depreciation is calculated using a straight line method to allocate the cost of the assets, net of their residual values, over their estimated useful lives as specified by Schedule II to the Act, wherever applicable. The estimated useful lives of the property, plant and equipment have been presented below:

Class of assets	Estimated useful life (in years)
Buildings	30 - 60 years
Plant and Equipment*	3 - 8 years
Furniture and Fixtures	10 years
Vehicles	5-8 years
Office equipment	5 years
Electrical installation	10 years

\*For these class of assets, based on internal assessment and independent technical evaluation carried out by external valuers, the Group believes that the useful lives as given above best represent the year over which Group expects to use these assets. Hence, the useful lives for these assets are different from the useful lives as prescribed under Part C of Schedule II to the Act.

ii) Leasehold improvements are depreciated over the shorter of their useful life or the lease term, unless the entity expects to use the assets beyond the lease term.

The assets' residual values and useful lives are reviewed by the management, and adjusted if appropriate, at the end of each reporting period.

## 2.5 Intangible assets

(i) Goodwill on acquisition of subsidiaries is included in intangible assets. Goodwill is not amortised but it is tested for impairment annually, or more frequently if events or changes in circumstances indicate that it might be impaired, and is carried at cost less accumulated impairment losses if any. Gains and Losses on the disposal of an entity include the carrying amount of goodwill relating to the entity sold.

Goodwill is allocated to cash-generating units for the purpose of impairment testing. The allocation is made to those cash-generating units or groups of cash-generating units that are expected to benefit from the business combination in which the goodwill arose. The units or groups of units are identified at the lowest level at which goodwill is monitored for internal management purposes.

(ii) Intangible Assets (Computer Software) are stated at cost of acquisition net of accumulated amortisation and accumulated impairment losses, if any. Costs associated with maintaining software programmes are recognised as an expense as incurred.

An asset's carrying amount is written down immediately to its recoverable amount if the asset's carrying amount is greater than its estimated recoverable amount.

Gains and losses on disposals are determined by comparing proceeds with carrying amount. These are included in the Restated Consolidated Statement of Profit and Loss.

On transition to Ind AS, the Group has elected to continue with the carrying value of its intangible assets measured at the previous GAAP and use that carrying value as the deemed cost of intangible assets.

### Amortisation

The group amortises computer software using the straight line method over the following periods:

Class of assets	Estimated useful life (in years)
Software	3 Years

### Research and Development Expenditure

Research expenditure and development expenditure that do not meet the criteria's mentioned below are recognised as an expense as incurred. Development costs previously recognised as an expense are not recognised as an asset in a subsequent period. Property, plant and equipment used in Research and Development are capitalised.

Development costs are recognised as intangible assets when the following criteria are met:

1. it is technically feasible to complete the intangible asset so that it will be available for use
2. management intends to complete the intangible asset and use or sell it
3. there is an ability to use or sell the intangible asset
4. it can be demonstrated how the intangible asset will generate probable future economic benefits
5. adequate technical, financial and other resources to complete the development and to use or sell the intangible asset are available, and
6. the expenditure attributable to the intangible asset during its development can be reliably measured.

Capitalised development costs are recorded as intangible assets and amortised from the point at which the asset is available for use.

### 2.6 Impairment

At each balance sheet date, the Group reviews the carrying values of its property, plant and equipment and intangible assets to determine whether there is any indication that the carrying value of those assets may not be recoverable through continuing use. If any such indication exists, the recoverable amount of the asset is reviewed in order to determine the extent of impairment loss (if any). Where the asset does not generate cash flows that are independent from other assets, the Group estimates the recoverable amount of the cash generating unit to which the asset belongs.

Recoverable amount is the higher of fair value less costs to sell and value in use. In assessing value in use, the estimated future cash flows are discounted to their present value using a pre-tax discount rate that reflects current market assessments of the time value of money and the risks specific to the asset for which the estimates of future cash flows have not been adjusted. An impairment loss is recognised in the Restated Consolidated Statement of Profit and Loss as and when the carrying value of an asset exceeds its recoverable amount.

Where an impairment loss subsequently reverses, the carrying value of the asset (or cash generating unit) is increased to the revised estimate of its recoverable amount so that the increased carrying value does not exceed the carrying value that would have been determined had no impairment loss been recognised for the asset (or cash generating unit) in prior years. A reversal of an impairment loss is recognised in the Restated Consolidated Statement of Profit and Loss immediately.

### 2.7 Investment Properties

Property that is held for long term rental yields or for capital appreciation or both, and is not occupied by the group, is classified as Investment property. Investment property is measured initially at its cost, including related transaction costs and where applicable borrowing costs. Subsequent expenditure is capitalised to the assets carrying amount only when it is probable that future economic benefits associated with the expenditure will flow to the group and the cost of the item can be measured reliably. All repair and maintenance cost are expensed when incurred. When part of Investment property is replaced, the carrying amount of the replaced part is derecognised.

On transition to Ind AS, the group has elected to continue with the carrying value of its investment properties measured at the previous GAAP and use that carrying value as the deemed cost of investment properties.

## **2.8 Business Combinations**

Acquisition of subsidiaries and businesses are accounted for using the acquisition method under Ind AS 103. The consideration transferred for acquisition of a business generally comprises of fair value of assets transferred, liabilities incurred by the Group to the former owners of the acquired business, and equity interests issued by the Group. Acquisition related costs are expenses as incurred in the Restated Consolidated Statement of Profit and Loss.

Goodwill arising on acquisition is recognised as an asset and measured at cost, being the excess of the consideration transferred in the business combination over the fair value of the net identifiable assets acquired. Where the fair value of the net identifiable assets exceed the consideration transferred, the difference is recognised in other comprehensive income and accumulated in equity as capital reserve provided there is clear evidence of the underlying reasons for classifying the business combination as a bargain purchase. In other cases, the bargain purchase gain is recognised directly in equity as capital reserve.

The group treats transactions with non-controlling interests that do not result in a loss of control as transactions with equity owners of the group. A change in ownership interest results in an adjustment between the carrying amounts of the controlling and non-controlling interests to reflect their relative interests in the subsidiary. Any difference between the amount of the adjustment to non-controlling interests and any consideration paid or received is recognised within equity.

Business combinations arising from transfers of interests in entities that are under the common control are accounted for using the pooling of interest method. The difference between any consideration transferred and the aggregate historical carrying values of assets and liabilities of the acquired entity are recognised in shareholder's equity.

When a transaction or other event does not meet the definition of a business combination due to the asset or group of assets not meeting the definition of a business, it is termed an 'asset acquisition'. In such circumstances, the acquirer:

- a) identifies and recognises the individual identifiable assets acquired
  - b) allocates the cost of the group of assets and liabilities to the individual identifiable assets and liabilities on the basis of their relative fair values at the date of purchase.
- Such a transaction or event does not give rise to goodwill or bargain purchase gain.

## **2.9 Financial Instruments**

### **Investment in debt instruments**

The financial assets are classified in the following categories:

1. financial assets measured at amortised cost,
2. financial assets measured at fair value through profit and loss (FVTPL), and
3. financial assets measured at fair value through other comprehensive income (FVOCI).

The classification of financial assets depends on the Group's business model for managing financial assets and the contractual terms of the cash flow.

At initial recognition, the financial assets are measured at its fair value plus, in the case of a financial asset not at fair value through profit and loss, transaction costs that are directly attributable to the acquisition of the financial asset. Transaction costs of financial assets carried at fair value through profit and loss are expensed in the Restated Consolidated Statement of Profit and Loss.

### **Financial assets measured at amortised cost**

Assets that are held for collection of contractual cash flows where those cash flows represent solely payments of principal and interest are measured at amortised cost. After initial recognition, such financial assets are subsequently measured at amortised cost using the effective interest rate method. The losses arising from impairment are recognised in the Restated Consolidated Statement of Profit and Loss.

### **Financial assets measured at fair value through other comprehensive income (FVOCI)**

Financial assets are measured at fair value through other comprehensive income if these financial assets are held within a business model whose objective is achieved by both collecting contractual cash flows and selling financial assets and the contractual terms of the financial asset give rise on specified dates to cash flows that are solely payments of principal and interest on the principal amount outstanding.

### **Financial assets measured at fair value through profit and loss (FVTPL)**

Assets that do not meet the criteria for amortised cost or FVOCI are measured at fair value through profit and loss. A gain or loss on a debt investment that is subsequently measured at fair value through profit and loss is recognised in the Restated Consolidated Statement of Profit and Loss in the period in which it arises.

Investments in units of mutual funds are subsequently measured at FVTPL and the changes in fair value are recognised in Restated Consolidated Statement of Profit and Loss.

### **De-recognition of financial asset**

A financial asset is derecognised only when

- The Group has transferred the rights to receive cash flows from the financial asset or
- Retains the contractual rights to receive the cash flows of the financial asset, but assumes a contractual obligation to pay the cash flows to one or more recipients.

### **Impairment of financial assets**

The Group assesses on a forward looking basis the expected credit losses associated with its financial assets carried at amortised cost and FVOCI debt instruments. The impairment methodology applied depends on whether there has been a significant increase in credit risk.

For trade receivables only, the group applies the simplified approach required by Ind AS 109, which requires expected lifetime losses to be recognised from initial recognition of the receivables.

## **Financial Liabilities**

Borrowings are initially recognised at fair value, net of transaction costs incurred. Financial liabilities are subsequently measured at amortised cost using the effective interest rate method. Any difference between the proceeds (net of transaction costs) and the redemption amount is recognised in the Restated Consolidated Statement of Profit and Loss over the period of the borrowings using the effective interest method. Borrowings are classified as current liabilities unless the Group has an unconditional right to defer settlement of the liability for at least 12 months after the reporting period. Where there is a breach of a material provision of a long-term loan arrangement on or before the end of the reporting period with the effect that the liability becomes payable on demand on the reporting date, the entity does not classify the liability as current, if the lender agreed, after the reporting period and before the approval of the Restated Consolidated Financial Information for issue, not to demand payment as a consequence of the breach.

Trade and other payables represent liabilities for goods and services provided to the group prior to the end of the financial year which are unpaid. The amounts are unsecured and are usually paid within 30-90 days of recognition. Trade and other payables are presented as current liabilities unless payment is not due within 12 months after the reporting period. They are recognised initially at their fair value and subsequently measured at amortised cost using the effective interest method.

### **De-recognition of financial liabilities**

A financial liability (or a part of financial liability) is de-recognised from Group's Restated Consolidated Statement of Assets and Liabilities when obligation specified in the contract is discharged or cancelled or expired.

### **Derivative Instruments**

Derivatives are only used for economic hedging purposes and not as speculative investments. The Group uses certain derivative financial instruments to reduce business risks which arise from its exposure to foreign exchange and interest rate fluctuations. The instruments are confined principally to forward foreign exchange contracts, interest rate swaps and options. The derivative contracts to hedge risks are not designated as hedges.

Derivatives are initially recognised at fair value on the date a derivative contract is entered into and are subsequently re-measured to their fair value at the end of each reporting period. Net mark to market gains/ losses on derivatives taken by the Group are recorded in other income/ expenses respectively.

### **Cash and Cash Equivalents**

For the purpose of presentation in the Restated Consolidated Statement of Cash Flows, cash and cash equivalents include cash on hand, demand deposits with banks, other short term highly liquid investments, if any, with original maturities of three months or less that are readily convertible to known amount of cash and subject to an insignificant change in value.

### **2.10 Offsetting Financial Instruments**

Financial assets and liabilities are offset and the net amount is reported in the Restated Consolidated Statement of Assets and Liabilities where there is a legally enforceable right to offset the recognised amounts and there is an intention to settle on a net basis or realise the asset and settle the liability simultaneously. The legally enforceable right must not be contingent on future events and must be enforceable in the normal course of business and in event of default, insolvency or bankruptcy of the Group or the counterparty.

### **2.11 Government Grants**

(i) Grants from the government are recognised at their fair value where there is a reasonable assurance that the grant will be received and the Group will comply with all attached conditions.

(ii) Government grants relating to income are deferred and recognised in the Restated Consolidated Statement of Profit and Loss over the period necessary to match them with the costs that they are intended to compensate and presented within other operating revenue.

### **2.12 Inventories**

Inventories are valued at the lower of cost and net realisable value. Cost of raw materials and traded goods comprises cost of purchases. Cost of work-in-progress and finished goods comprises direct materials, direct labours and an appropriate proportion of variable and fixed overhead expenditure, the latter being allocated on the basis of normal operating capacity. Cost of inventories also include all other costs incurred in bringing the inventories to their present location and condition. Costs are assigned to individual items of inventory on the basis of weighted-average cost method. Net realisable value is the estimated selling price in the ordinary course of business less the estimated costs of completion and the estimated costs necessary to make the sale.

### **2.13 Revenue Recognition**

Revenue shall be recognised to depict the transfer of promised goods or services to customers in an amount that reflects the consideration to which the entity expects to be entitled in exchange for those goods and services.

### **Sales of goods**

Sales are recognised when control of the products has been transferred to the buyer, being when the products are dispatched/ delivered to the customer depending on the contract terms. This occurs when the products have been shipped or delivered to the specific location as the case may be, the risk of loss has been transferred, and either the customer has accepted the products in accordance with the sales contract, or the Group has objective evidence that all criteria for acceptance have been satisfied. Revenue from contract with customers is primarily recorded at a point in time. In few contracts the Group's performance does not create an asset with alternative use to the group and the group has concluded that it has an enforceable right to payment for performance completed to date. In the said cases, the group transfers control of a good or service over time and, therefore, satisfies a performance obligation and recognises revenue over time. The group uses the input method to recognise revenue.

The group has determined that the input method is the best method for measuring progress for these contracts because there is a direct relationship between the costs incurred by the Group and the transfer of goods and services to the customer.

No element of financing is deemed present as the sales are generally made with a credit term upto 180 days which is consistent with market practice.

Revenue is recognised based on the price specified in the contract.

Some contracts include multiple deliverables, such as sale of product and certain related services. However, the services are simple, does not include an integration service and could be performed by another party. It is therefore accounted for as a separate performance obligation. Where the contracts include multiple performance obligations, the transaction price will be allocated to each performance obligation based on the stand-alone selling prices. Where these are not directly observable, they are estimated based on the expected cost plus margin. If contracts include the installation of product, revenue for the product is recognized at a point in time when the product is delivered, the legal title has passed and the customer has accepted the product.

A receivable is recognised when the goods are dispatched or delivered, depending on the contract terms, as this is the point in time that the consideration is unconditional because only the passage of time is required before the payment is due.

A contract asset is recognised in respect of those performance obligations where the control of the goods has been transferred to the buyer, and only delivery of the goods is pending. In these cases the consideration is due after the shipping obligation is complete, accordingly these are classified as contract assets as the consideration is conditional on something other than the passage of time.

The group does not have any contracts where the period between the transfer of the promised goods or services to the customer and payment by the customer exceeds one year. As a consequence, the Group does not adjust any of the transaction prices for the time value of money.

The group generally provides for warranties which are assurance-type warranties under Ind AS 115, and are accounted for under Ind AS 37 Provisions, Contingent Liabilities and Contingent Assets.

### **2.14 Other Income**

**Interest:** Interest income is calculated by applying the effective interest rate to the gross carrying amount of a financial asset.

**Dividend:** Dividend income from investments is recognised when the shareholder's rights to receive payment is established.

### **2.15 Borrowing Costs**

Borrowing costs include interest, other costs incurred in connection with borrowing and exchange differences arising from foreign currency borrowings to the extent that they are regarded as an adjustment to the interest cost. General and specific borrowing costs directly attributable to the acquisition, construction or production of qualifying assets, are capitalised during the period of time that is required to complete and prepare the assets for its intended use or sale. Qualifying assets are assets that necessarily take a substantial period of time to get ready for their intended use or sale. All other borrowing costs are expensed in the period in which they are incurred.

### **2.16 Foreign Currencies**

#### **Functional and presentation currency**

These Restated Consolidated Financial Information of the Group are presented in Indian rupees (INR), which is the functional currency of the Holding Company and the presentation currency for the financial statements.

#### **Transaction and Balances**

Transactions in foreign currencies are translated into the functional currency at exchange rates prevailing on the date of the transaction. Foreign exchange gains and losses resulting from the settlement of such transactions are generally recognised in the Restated Consolidated Statement of Profit and Loss.

Monetary assets and liabilities related to such foreign currency transactions at the end of the period/ year are translated at period/ year end exchange rates and are generally recognised in the Restated Consolidated Statement of Profit and Loss. Non-monetary assets and non-monetary liabilities denominated in a foreign currency and measured at fair value are translated at the exchange rate prevalent at the date when the fair value was determined. Non-monetary assets and non-monetary liabilities denominated in a foreign currency and measured at historical cost are translated at the exchange rate prevalent at the date of transaction.

#### **Foreign Operations**

The result and financial position of foreign operations (none of which has the currency of a hyper-inflationary economy) that have a functional currency different from the presentation currency are translated into the presentation currency as follows:

1. Assets and liabilities are translated at the closing rate at the date of the Restated Consolidated Statement of Assets and Liabilities.
2. Income and expenses are translated at average exchange rates (unless this is not a reasonable approximation of cumulative effect of the rates prevailing on the transaction dates, in which case income and expenses are translated at the dates of the transactions), and
3. All resulting exchange differences are recognised in Other Comprehensive Income.

On consolidation, exchange differences arising from the translation of any net investment in foreign entities, are recognised in other comprehensive income.

Goodwill and fair value adjustments arising on the acquisition of a foreign operation are treated as assets and liabilities of the foreign operation and translated at the exchange rate in effect at the balance sheet date.

### **2.17 Employee Benefits**

#### **a) Short-term Employee Benefits:**

Short-term Employee Benefits (i.e. benefits payable within one year) are recognised in the period in which employee services are rendered.

#### **b) Defined contribution plans**

Payments to defined contribution plans are charged as an expense as they fall due. Payments made to state managed retirement benefit schemes are dealt with as payments to defined contribution schemes as the group has no further payment obligations once the contributions have been paid.

#### **c) Defined benefit plans**

For defined benefit retirement schemes the cost of providing benefits is determined using the Projected Unit Credit Method, with actuarial valuation being carried out at each balance sheet date. Re-measurement gains and losses of the net defined benefit liability/ (asset) are recognised immediately in other comprehensive income. The service cost and net interest on the net defined benefit liability/ (asset) is treated as a net expense within employment costs.

Past service cost is recognised as an expense when the plan amendment or curtailment occurs or when any related restructuring costs or termination benefits are recognised, whichever is earlier.

The retirement benefit obligation recognised in the Restated Consolidated Statement of Assets and Liabilities represents the present value of the defined-benefit obligation as reduced by the fair value plan assets.

#### **d) Other Long-term Employee Benefits:**

##### **Compensated absences**

Accumulated compensated absences which are expected to be availed or encashed within twelve months from the period/ year end are treated as short term employee benefits. The obligation towards the same is measured at the expected cost of accumulating compensated absences as the additional amount expected to be paid as a result of the unused entitlements as at the period/ year end.

Accumulated compensated absences which are expected to be availed or encashed beyond twelve months from the period/ year end are treated as other long term employee benefits. The Group's liability is actuarially determined (using the Projected Unit Credit method) at the end of each period/ year. Actuarial loss/ gains are recognised in the Restated Consolidated Statement of Profit and Loss in the period/ year in which they arise.

#### **e) Share based payments**

Share-based compensation benefits are provided to employees via the Tega Industries Limited Employee Stock Option Scheme namely ESOP Scheme 2011. Employees of the holding company receive remuneration in the form of share-based payments, whereby employees render services as consideration for equity instruments (equity-settled transactions).

The cost of equity-settled transactions is determined by the fair value at the date when the grant is made using an appropriate valuation model. That cost is recognised, together with a corresponding increase in Employee Stock Options Outstanding Account in equity, over the period in which the performance and/or service conditions are fulfilled, in Employee Benefit Expense. The cumulative expense recognised for equity-settled transactions at each reporting date until the vesting date reflects the extent to which the vesting period has expired and the Company's best estimate of the number of equity instruments that will ultimately vest. Service and non-market performance conditions are not taken into account when determining the grant date fair value of awards, but the likelihood of the conditions being met is assessed as part of the Company's best estimate of the number of equity instruments that will ultimately vest. Market performance conditions are reflected within the grant date fair value. The dilutive effect of outstanding options is reflected as additional share dilution in the computation of diluted earnings per share.

### **2.18 Current and Deferred Tax**

The current income tax charge is calculated on the basis of the tax laws enacted or substantively enacted at the end of the reporting period in the countries where the Parent Company and its subsidiaries operate and generate taxable income. Management periodically evaluates positions taken in tax returns with respect to situations in which applicable tax regulation is subject to interpretation. It establishes provisions where appropriate on the basis of amounts expected to be paid to the tax authorities.

Deferred income tax is provided in full, using the liability method, on temporary differences arising between the tax bases of assets and liabilities and their carrying amounts in the Restated Consolidated Financial Information. However, deferred tax liabilities are not recognised if they arise from the initial recognition of goodwill. Deferred income tax is also not accounted for if it arises from initial recognition of an asset or liability in a transaction other than a business combination that at the time of the transaction affects neither accounting profit nor taxable profit (tax loss). Deferred income tax is determined using tax rates (and laws) that have been enacted or substantively enacted by the end of the reporting period and are expected to apply when the related deferred income tax asset is realised or the deferred income tax liability is settled.

Deferred tax assets are recognised for all deductible temporary differences and unused tax losses only if it is probable that future taxable amounts will be available to utilise those temporary differences and losses.

Deferred tax liabilities are not recognised for temporary differences between the carrying amount and tax bases of investments in subsidiaries, branches and interest in joint arrangements where the Group is able to control the timing of the reversal of the temporary differences and it is probable that the differences will not reverse in the foreseeable future.

Deferred tax assets are not recognised for temporary differences between the carrying amount and tax bases of investments in subsidiaries, branches and associates and interest in joint arrangements where it is not probable that the differences will reverse in the foreseeable future and taxable profit will not be available against which the temporary difference can be utilised.

Deferred tax assets and liabilities are offset when there is a legally enforceable right to offset current tax assets and liabilities and when the deferred tax balances relate to the same taxation authority. Current tax assets and tax liabilities are offset where the entity has a legally enforceable right to offset and intends either to settle on a net basis, or to realise the asset and settle the liability simultaneously.

Current and deferred tax is recognised in the Restated Consolidated Statement of Profit and Loss, except to the extent that it relates to items recognised in other comprehensive income or directly in equity. In this case, the tax is also recognised in the other comprehensive income or directly in equity, respectively.

Minimum Alternate Tax (MAT) credit is recognised as an asset only when and to the extent there is convincing evidence that the group will pay normal income tax during the specified period. Such asset is reviewed at each Balance Sheet date and the carrying amount of the MAT credit asset is written down to the extent there is no longer a convincing evidence to the effect that the Group will pay normal income tax during the specified period.

### **2.19 Provision and Contingent Liabilities**

The Group recognises a provision where there is a present obligation as a result of a past event that probably requires an outflow of resources and a reliable estimate can be made of the amount of the obligation. However, provisions are not recognised for future operating losses.

Where there are a number of similar obligations, the likelihood that an outflow will be required in settlement is determined by considering the class of obligations as a whole. A provision is recognised even if the likelihood of an outflow with respect to any one item included in the same class of obligations may be small.

Provisions are measured at the present value of management's best estimate of the expenditure required to settle the present obligation at the end of the reporting period. The discount rate used to determine the present value is a pre-tax rate that reflects current market assessments of the time value of money and the risks specific to the liability. The increase in the provision due to the passage of time is recognised as interest expense.

A disclosure for a contingent liability is made when there is a possible obligation or a present obligation that may, but probably will not, require an outflow of resources or there is a present obligation, reliable estimate of the amount of which cannot be made. Where there is a possible obligation or a present obligation and the likelihood of outflow of resources is remote, no provision or disclosure for contingent liability is made.

#### Provision for warranty

The estimated liability for warranty is recorded when products are sold. These estimates are established using historical information on the nature, frequency and average cost of obligations and management estimates regarding possible future incidence based on corrective actions on product failure.

### **2.20 Non-current assets (or disposal Groups) held for sale and discontinued operations**

A discontinued operation is a component of the entity that has been disposed of or is classified as held for sale and that represents a separate major line of business or geographical area of operations, is part of a single co-ordinated plan to dispose of such a line of business or area of operations, or is a subsidiary acquired exclusively with a view to resale. The results of discontinued operations are presented separately in the Restated Consolidated Statement of Profit and Loss.

Non-current assets classified as held for sale and the assets of a disposal Group classified as held for sale are presented separately from the other assets in the Restated Consolidated Statement of Assets and Liabilities. The liabilities of a disposal Group classified as held for sale are presented separately from other liabilities in the Restated Consolidated Statement of Assets and Liabilities.

Non-current assets (or disposal Groups) are classified as held for sale if their carrying amount will be recovered principally through a sale transaction rather than through continuing use and a sale is considered highly probable. They are measured at the lower of their carrying amount and fair value less costs to sell, except for assets such as deferred tax assets, assets arising from employee benefits, financial assets and contractual rights under insurance contracts, which are specifically exempt from this requirement.

### **2.21 Earnings per Share**

Basic earnings per share is calculated by dividing net profit or loss for the period attributable to equity shareholders by the weighted average number of equity shares outstanding during the period/ year. Earnings considered in ascertaining the Group's earnings per share is the net profit or loss for the period/ year. The weighted average number of equity shares outstanding during the period/ year and for all periods presented is adjusted for events, such as bonus shares, other than the conversion of potential equity shares, if any, that have changed the number of equity shares outstanding, without a corresponding change in resources. For the purpose of calculating diluted earnings per share, the net profit or loss for the period/ year attributable to equity shareholders and the weighted average number of shares outstanding during the period/ year are adjusted for the effects of all dilutive potential equity shares.

## **2.22 Segment reporting**

Operating segments are reported in a manner consistent with the internal reporting provided to the chief operating decision maker. The executive committee of the holding company assesses the financial performance and the position of the Group and they are the chief operating decision maker of the Group.

## **2.23 Exceptional Item**

Exceptional item is an item of income or expense within the Restated Consolidated Statement of Profit and Loss, which is of such size, nature and incidence that its disclosure is relevant to explain the performance of the Group for the period/ year. The nature and amount of such item is disclosed separately in the Restatement Consolidated Statement of Profit and Loss.

## **2.24 Leases**

### **The Group as lessee**

The Group accounts for each lease component within the contract as a lease separately from non-lease components of the contract and allocates the consideration in the contract to each lease component on the basis of the relative stand-alone price of the lease component and the aggregate stand-alone price of the non-lease components. The Group recognises right-of-use asset representing its right to use the underlying asset for the lease term at the lease commencement date. The cost of the right of-use asset measured at inception comprises of the amount of initial measurement of the lease liability adjusted for any lease payments made at or before the commencement date.

Certain lease arrangements include options to extend or terminate the lease before the end of the lease term. The right-of-use assets and lease liabilities include these options when it is reasonably certain that such options would be exercised.

The right-of-use assets is subsequently measured at cost less any accumulated depreciation, accumulated impairment losses, if any and adjusted for any re-measurement of the lease liability. The right-of-use assets is depreciated using the straight-line method from the commencement date over the shorter of lease term or useful life of right-of-use asset.

Right-of-use assets are tested for impairment whenever there is any indication that their carrying amounts may not be recoverable. Impairment loss, if any, is recognized in the Restated Consolidated Statement of Profit and Loss.

Lease liability is measured at the present value of the lease payments that are not paid at the commencement date of the lease. The lease payments are discounted using the interest rate implicit in the lease, if that rate can be readily determined. If that rate cannot be readily determined, the Group uses incremental borrowing rate. The lease liability is subsequently remeasured by increasing the carrying amount to reflect interest on the lease liability, reducing the carrying amount to reflect the lease payments made and remeasuring the carrying amount to reflect any reassessment or lease modifications. The Group recognizes the amount of the re-measurement of lease liability as an adjustment to the right-of-use asset. Where the carrying amount of the right-of-use asset is reduced to zero and there is a further reduction in the measurement of the lease liability, the Group recognizes any remaining amount of the re-measurement in the Restated Consolidated Statement of Profit and Loss.

Variable lease payments not included in the measurement of the lease liabilities are expensed to the Restated Consolidated Statement of Profit and Loss in the period/ year in which the events or conditions which trigger those payments occur.

## **2.25 IPO Expenses**

The transaction costs incurred by the Holding Company on behalf of the selling shareholders, with respect to the proposed IPO, are recognised as an asset in the Restated Consolidated Statement of Assets and Liabilities, as they are recoverable from the selling shareholders.

## **2A Critical estimates and judgements**

The preparation of Restated Consolidated Financial Information requires the use of accounting estimates which, by definition, will seldom equal the actual results. Management also needs to exercise judgement in applying the Group's accounting policies.

This note provides an overview of the areas that involved a higher degree of judgement or complexity, and of items which are more likely to be materially adjusted due to estimates and assumptions turning out to be different than those originally assessed.

### **(i) Estimation of defined benefit obligation**

Refer note 38 for details of critical estimates in computation of defined benefit obligation.

### **(ii) Impairment of Goodwill**

Goodwill is tested for impairment at least on annual basis or more frequently when events or change in circumstances indicate that it might be impaired. The recoverable amount of the Cash Generating Unit (CGU) is determined based on value in use calculations which require the use of assumptions. The calculations use cash flow projection based on financial budgets approved by management covering a five year period. The Group uses various assumptions inter-alia growth in the revenue, earnings before Interest, tax depreciation and amortisation (EBITDA), long term growth rates, discount rates to reflect the risk involved.

### **(iii) Deferred Taxes**

The Group reviews the carrying amount of deferred tax assets at the end of the each reporting period/ year. The policy has been detailed in note 2.18 and judgements related to deferred taxes is set out in note 37.

### **(iv) Critical judgement in determining the lease term**

The Group determines the lease term on the basis of termination and renewal options in various lease contracts where the Group applies its judgements. Refer note 3(b) for details.

Note: 3(a) Property, plant and equipment

Particulars	Land	Buildings	Plant and equipment	Furniture and fixtures	Vehicles	Office equipment	Electrical installation	Total
<b>Gross Block</b>								
<b>As at 1 April 2018</b>	<b>109.96</b>	<b>757.12</b>	<b>1,681.86</b>	<b>63.04</b>	<b>68.26</b>	<b>66.33</b>	<b>3.19</b>	<b>2,749.76</b>
Additions during the year	-	6.03	187.22	28.82	18.19	4.04	-	244.30
Disposals/ Adjustments during the year#	(0.55)	-	(34.85)	(14.98)	(11.31)	(4.57)	-	(66.26)
Exchange Differences	(7.24)	(22.64)	(80.62)	(4.71)	(2.70)	(4.52)	(0.58)	(123.01)
<b>As at 31 March 2019</b>	<b>102.17</b>	<b>740.51</b>	<b>1,753.61</b>	<b>72.17</b>	<b>72.44</b>	<b>61.28</b>	<b>2.61</b>	<b>2,804.79</b>
Ind AS 116 transition adjustment	0.55	-	7.59	-	-	-	-	8.14
<b>As at 1 April 2019</b>	<b>102.72</b>	<b>740.51</b>	<b>1,761.20</b>	<b>72.17</b>	<b>72.44</b>	<b>61.28</b>	<b>2.61</b>	<b>2,812.93</b>
Additions during the year	-	-	195.72	7.93	32.42	1.84	-	237.91
Disposals/ Adjustments during the year##	(0.55)	(3.42)	(26.81)	(1.29)	(13.80)	(0.94)	-	(46.81)
Exchange Differences	(4.82)	(14.00)	(76.08)	(7.71)	(2.72)	(2.54)	(0.01)	(107.88)
<b>As at 31 March 2020</b>	<b>97.35</b>	<b>723.09</b>	<b>1,854.03</b>	<b>71.10</b>	<b>88.34</b>	<b>59.64</b>	<b>2.60</b>	<b>2,896.15</b>
<b>As at 1 April 2020</b>	<b>97.35</b>	<b>723.09</b>	<b>1,854.03</b>	<b>71.10</b>	<b>88.34</b>	<b>59.64</b>	<b>2.60</b>	<b>2,896.15</b>
Additions during the year	-	1.54	198.44	14.53	19.01	9.38	0.39	243.29
Disposals/ Adjustments during the year	-	-	(36.99)	(0.18)	(9.94)	(2.58)	-	(49.69)
Exchange Differences	6.30	18.39	91.96	9.74	6.42	4.14	0.02	136.97
<b>As at 31 March 2021</b>	<b>103.65</b>	<b>743.02</b>	<b>2,107.44</b>	<b>95.19</b>	<b>103.83</b>	<b>70.58</b>	<b>3.01</b>	<b>3,226.72</b>
<b>As at 1 April 2021</b>	<b>103.65</b>	<b>743.02</b>	<b>2,107.44</b>	<b>95.19</b>	<b>103.83</b>	<b>70.58</b>	<b>3.01</b>	<b>3,226.72</b>
Additions during the period	-	-	62.76	1.43	-	0.67	-	64.86
Disposals/ Adjustments during the period	-	-	-	-	(3.62)	(0.10)	-	(3.72)
Exchange Differences	2.38	6.94	16.95	0.90	(0.90)	0.82	-	28.89
<b>As at 30 June 2021</b>	<b>106.03</b>	<b>749.96</b>	<b>2,187.15</b>	<b>97.52</b>	<b>101.11</b>	<b>71.97</b>	<b>3.01</b>	<b>3,316.75</b>
<b>Accumulated Depreciation</b>								
<b>As at 1 April 2018</b>	<b>0.82</b>	<b>60.73</b>	<b>587.88</b>	<b>24.69</b>	<b>20.70</b>	<b>31.16</b>	<b>1.48</b>	<b>727.46</b>
Charge for the year	0.33	29.13	258.43	11.87	10.74	8.32	1.41	320.23
Disposals/ Adjustments during the year#	(0.22)	-	(17.07)	(0.88)	(5.94)	(2.90)	-	(37.01)
Exchange Differences	-	(3.68)	(45.71)	(2.57)	(2.16)	(3.88)	(0.45)	(58.45)
<b>As at 31 March 2019</b>	<b>0.93</b>	<b>86.18</b>	<b>783.53</b>	<b>23.11</b>	<b>23.34</b>	<b>32.70</b>	<b>2.44</b>	<b>952.23</b>
Ind AS 116 transition adjustment	0.23	-	1.94	-	-	-	-	2.17
<b>As at 1 April 2019</b>	<b>1.16</b>	<b>86.18</b>	<b>785.47</b>	<b>23.11</b>	<b>23.34</b>	<b>32.70</b>	<b>2.44</b>	<b>954.40</b>
Charge for the year	0.33	27.88	248.42	12.65	13.33	6.12	0.16	308.89
Disposals/ Adjustments during the year##	(0.23)	(0.60)	(12.81)	(0.39)	(7.05)	(0.85)	-	(21.93)
Exchange Differences	-	(2.76)	(28.01)	(2.53)	(1.56)	(1.84)	-	(36.70)
<b>As at 31 March 2020</b>	<b>1.26</b>	<b>110.70</b>	<b>993.07</b>	<b>32.84</b>	<b>28.06</b>	<b>36.13</b>	<b>2.60</b>	<b>1,204.66</b>
<b>As at 1 April 2020</b>	<b>1.26</b>	<b>110.70</b>	<b>993.07</b>	<b>32.84</b>	<b>28.06</b>	<b>36.13</b>	<b>2.60</b>	<b>1,204.66</b>
Charge for the year	0.33	28.17	242.91	13.50	14.54	7.15	0.19	306.79
Disposals/ Adjustments during the year	-	-	(27.55)	(0.12)	(6.49)	(1.95)	-	(36.11)
Exchange Differences	-	4.21	43.46	4.79	4.15	2.81	0.00 <sup>^</sup>	59.42
<b>As at 31 March 2021</b>	<b>1.59</b>	<b>143.08</b>	<b>1,251.89</b>	<b>51.01</b>	<b>40.26</b>	<b>44.14</b>	<b>2.79</b>	<b>1,534.76</b>
<b>As at 1 April 2021</b>	<b>1.59</b>	<b>143.08</b>	<b>1,251.89</b>	<b>51.01</b>	<b>40.26</b>	<b>44.14</b>	<b>2.79</b>	<b>1,534.76</b>
Charge for the period	0.08	6.98	64.78	2.34	3.96	1.43	0.05	79.62
Disposals/ Adjustments during the period	-	-	-	-	(2.65)	(0.06)	-	(2.71)
Exchange Differences	-	1.78	8.96	0.37	0.32	0.53	0.00 <sup>^</sup>	11.96
<b>As at 30 June 2021</b>	<b>1.67</b>	<b>151.84</b>	<b>1,325.63</b>	<b>53.72</b>	<b>41.89</b>	<b>46.04</b>	<b>2.84</b>	<b>1,623.63</b>
<b>Net Carrying Value</b>								
<b>As at 31 March 2019</b>	<b>101.24</b>	<b>654.33</b>	<b>970.08</b>	<b>49.06</b>	<b>49.10</b>	<b>28.58</b>	<b>0.17</b>	<b>1,852.56</b>
<b>As at 31 March 2020</b>	<b>96.09</b>	<b>612.39</b>	<b>860.96</b>	<b>38.26</b>	<b>38.26</b>	<b>23.51</b>	<b>-</b>	<b>1,691.49</b>
<b>As at 31 March 2021</b>	<b>102.06</b>	<b>599.94</b>	<b>855.55</b>	<b>44.18</b>	<b>63.57</b>	<b>26.44</b>	<b>0.22</b>	<b>1,691.96</b>
<b>As at 30 June 2021</b>	<b>104.36</b>	<b>598.12</b>	<b>861.52</b>	<b>43.80</b>	<b>59.22</b>	<b>25.93</b>	<b>0.17</b>	<b>1,693.12</b>

<sup>^</sup>Amount is below the rounding off norm adopted by the Group

# Includes in Gross Block and Accumulated depreciation of Land INR 0.55 Mn and INR 0.23 Mn respectively and Gross Block and Accumulated depreciation of Plant and equipment INR 8.88 Mn and INR 1.60 Mn respectively for the year ended 31 March 2019 which has been transferred to Right-of-Use Assets on adoption of Ind AS 116.

## Includes in Gross Block and Accumulated depreciation of Land INR 0.55 Mn and INR 0.23 Mn respectively and Gross Block and Accumulated depreciation of Plant and equipment INR 9.16 Mn and INR 6.99 Mn respectively for the year ended 31 March 2020 which has been transferred to Right-of-Use Assets on adoption of Ind AS 116.

Note:

(i) Refer note 20 and 23 for Property, plant and equipment pledged as security.

(ii) Contractual obligations

Refer to note 44B for disclosure of contractual commitments for the acquisition of property, plant and equipment.

(iii) Gross and net carrying amount of freehold land INR NIL (31 March 2021: INR NIL ; 31 March 2020: INR 4.40 Mn) and freehold building Gross Block INR NIL (31 March 2021: INR NIL ; 31 March 2020: INR 3.38 Mn) and Net Block INR NIL (31 March 2021: INR NIL, 31 March 2020: INR 3.00 Mn and 31 March 2019: INR 3.05 Mn) was in the name of the erstwhile company, Tega Industries (SEZ) Limited which was a wholly owned subsidiary of Holding Company, subsequently got merged with the Holding Company effective 1 October 2016:

Title deeds of immovable property not held in name of the Holding Company

(a) As at 31 March 2019

Relevant line item in the Restated Consolidated Balance Sheet	Description of the property	Gross carrying amount	Title deed held in the name of	Whether title deed holder is promoter, director or relative of promoter/ director or employee of promoter/ director	Property held since	Reason for not being held in the name of the company
Property, plant and equipment	Land	4.40	Tega Industries (SEZ) Limited	No	1 October 2016*	Merger of Tega Industries (SEZ) Limited with the Holding Company, Tega Industries Limited.
Property, plant and equipment	Building	3.38	Tega Industries (SEZ) Limited	No	1 October 2016*	Merger of Tega Industries (SEZ) Limited with the Holding Company, Tega Industries Limited.

(b) As at 31 March 2020

Relevant line item in the Restated Consolidated Balance Sheet	Description of the property	Gross carrying amount	Title deed held in the name of	Whether title deed holder is promoter, director or relative of promoter/ director or employee of promoter/ director	Property held since	Reason for not being held in the name of the company
Property, plant and equipment	Land	4.40	Tega Industries (SEZ) Limited	No	1 October 2016*	Merger of Tega Industries (SEZ) Limited with the Holding Company, Tega Industries Limited.
Property, plant and equipment	Building	3.38	Tega Industries (SEZ) Limited	No	1 October 2016*	Merger of Tega Industries (SEZ) Limited with the Holding Company, Tega Industries Limited.

\* Being the date of merger of Tega Industries (SEZ) Limited with Tega Industries Limited.

The property was subsequently registered in the name of Holding Company i.e. Tega Industries Limited on 15 February 2021

(iv) There are no proceedings against the holding company and its joint venture, being the Companies register under "the Act", that have been initiated or pending against them for holding any benami property under the Benami Transactions (Prohibition) Act, 1988 (45 of 1988) and the rules made thereunder.



**Note 3(b): Right of Use Assets**

**(a) The Group as a lessee**

The Group's significant leasing arrangements include assets dedicated for use under long-term arrangements, lease of land, office space, equipment, vehicles and some IT equipment. Lease of land have lease term of 60 years, leases of plant and equipment and office equipments have lease terms between 2 to 30 years, offices and guest houses generally have lease terms between 12 months to 60 years and vehicle generally have lease term between 2 years to 5 years. Lease terms are negotiated on an individual basis and contain a wide range of different terms and conditions. Until 31 March 2019, leases were classified as either finance leases or operating leases. From 1 April 2019, leases are recognised as a right-of-use asset and a corresponding liability at the date at which the leased asset is available for use by the group. The group also has certain leases of offices and guest houses with lease term of 12 months or less. The group applies the 'short-term lease' recognition exemptions for these leases. For leases recognised under long term arrangements involving use of a dedicated asset, non-lease components are excluded based on the underlying contractual terms and conditions.

For the purpose of preparing Restated Consolidated Financial Information, Ind AS 116 has been applied retrospectively with effect from 1 April 2018.

**(b) Transition related disclosures**

(i) The weighted average incremental borrowing rate applied to lease liabilities as at 1 April 2018 ranges from 2.59% to 11.70%.

(ii) The following is the summary of practical expedients elected on initial application-

- accounting for operating leases with a remaining lease term of less than 12 months as at 1 April 2018 as short-term leases,
- excluding initial direct costs for the measurement of the right-of-use asset at the date of initial application, and
- using hindsight in determining the lease term where the contract contains options to extend or terminate the lease.

**The effect of adoption of Ind AS 116 is as follows**

Particulars	31 March 2020	31 March 2019
<b>Restated Consolidated Statement of Assets and Liabilities</b>		
<b>Assets</b>		
<b>Non-current assets</b>		
Right-of-use assets	405.86	385.85
<b>Total assets</b>	<b>405.86</b>	<b>385.85</b>
<b>Liabilities</b>		
Lease liabilities - Non current	247.89	243.63
Lease liabilities - Current	92.81	64.56
<b>Total liabilities</b>	<b>340.70</b>	<b>308.19</b>
<b>Restated Consolidated Statement of Profit and Loss</b>		
Depreciation on right-of-use assets	70.84	51.34
Rent	(79.27)	(66.28)
Finance cost on lease liabilities	25.71	29.11
<b>Impact on restated profit before share of restated net profit of joint venture accounted for using equity method and tax</b>	<b>17.28</b>	<b>14.17</b>
Impact on share of restated profit of joint venture accounted for using the equity method	-	0.09
<b>Impact on restated profit for the year</b>	<b>17.28</b>	<b>14.26</b>
<b>Restated Consolidated Statement of Cash Flows</b>		
<b>Net cash inflow from operating activities (A)</b>	79.27	65.65
<b>Net cash outflow from financing activities (B)</b>	(79.27)	(65.65)
<b>Net increase in cash and cash equivalents during the year (A+B)</b>	-	-

There is no material impact on other comprehensive income or on basic and diluted earning per share.

The above statement should be read with Annexure VI - Statement of Adjustments to the Audited Special Purpose Interim Consolidated Financial Statements as at and for the three months period ended June 30, 2021 and Audited Consolidated Financial Statements as at and for the years ended March 31, 2021, March 31, 2020 and March 31, 2019

**(c) The reconciliation of total operating lease commitments as at 31 March 2018 and 31 March 2019 to the lease liabilities recognised on transition is as below**

Particulars	Amount
Operating lease commitments as at 31 March 2018	50.49
Adjustments as a result of a different treatment of extension and termination options	581.05
<b>Undiscounted operating lease commitments as at 1 April 2018</b>	<b>631.54</b>
Effect of discounting using the lessee's incremental borrowing rate as at 1 April 2018	(290.79)
<b>Lease liabilities recognised as on 1 April 2018</b>	<b>340.75</b>

Particulars	Amount
Operating lease commitments as at 31 March 2019	33.52
Adjustments as a result of a different treatment of extension and termination options	457.18
<b>Undiscounted operating lease commitments as at 1 April 2019</b>	<b>490.70</b>
Effect of discounting using the lessee's incremental borrowing rate as at 1 April 2019	(245.96)
<b>Lease liabilities recognised as on 1 April 2019</b>	<b>244.74</b>

d) Following are the changes in carrying value of right-of-use assets

Particulars	Right-of-Use Land	Right-of-Use Buildings	Right-of-Use Plant and Equipment	Right-of-Use Office Equipment	Right-of-Use Vehicle	Total Right-of-Use Assets
<b>Gross Block</b>						
<b>As at 1 April 2018 (At cost)</b>	-	-	-	-	-	-
Ind AS 116 transition*	89.11	127.42	210.79	-	7.13	434.45
<b>Revised Balance as at 1 April 2018</b>	<b>89.11</b>	<b>127.42</b>	<b>210.79</b>	-	<b>7.13</b>	<b>434.45</b>
Additions during the year	-	5.30	4.44	5.20	-	14.94
Exchange Differences	-	(0.58)	(11.39)	(0.31)	(0.27)	(12.55)
<b>As at 31 March 2019 (At cost)</b>	<b>89.11</b>	<b>132.14</b>	<b>203.84</b>	<b>4.89</b>	<b>6.86</b>	<b>436.84</b>
Ind AS 116 transition adjustment	(1.67)	(89.44)	(6.97)	(0.29)	(2.64)	(101.01)
<b>As at 1 April 2019 (At cost)</b>	-	-	-	-	-	-
Ind AS 116 transition**	87.44	42.70	196.87	4.60	4.22	335.83
<b>Revised Balance as at 1 April 2019</b>	<b>87.44</b>	<b>42.70</b>	<b>196.87</b>	<b>4.60</b>	<b>4.22</b>	<b>335.83</b>
Additions during the year	-	69.30	74.10	15.03	12.87	171.30
Assets disposed/ discarded during the year	-	(0.56)	-	-	-	(0.56)
Exchange Differences	-	(1.22)	(29.05)	(0.52)	(0.93)	(31.72)
<b>As at 31 March 2020 (At cost)</b>	<b>87.44</b>	<b>110.22</b>	<b>241.92</b>	<b>19.11</b>	<b>16.16</b>	<b>474.85</b>
<b>As at 1 April 2020 (At cost)</b>	<b>87.44</b>	<b>110.22</b>	<b>241.92</b>	<b>19.11</b>	<b>16.16</b>	<b>474.85</b>
Additions during the year	-	231.91	9.57	-	2.90	244.38
Assets disposed / discarded during the year	-	-	(2.05)	-	(1.36)	(3.41)
Exchange Differences	-	5.45	29.65	0.68	2.11	37.89
<b>As at 31 March 2021 (At cost)</b>	<b>87.44</b>	<b>347.58</b>	<b>279.09</b>	<b>19.79</b>	<b>19.81</b>	<b>753.71</b>
<b>As at 1 April 2021 (At cost)</b>	<b>87.44</b>	<b>347.58</b>	<b>279.09</b>	<b>19.79</b>	<b>19.81</b>	<b>753.71</b>
Additions during the period	-	6.35	29.59	-	1.64	37.58
Assets disposed / discarded during the period	-	-	(14.95)	-	-	(14.95)
Exchange Differences	-	0.53	2.67	0.26	0.53	3.99
<b>As at 30 June 2021 (At cost)</b>	<b>87.44</b>	<b>354.46</b>	<b>296.40</b>	<b>20.05</b>	<b>21.98</b>	<b>780.33</b>
<b>Accumulated Depreciation</b>						
<b>As at 1 April 2018</b>	-	-	-	-	-	-
Charge for the year #	1.68	37.58	9.56	0.69	2.45	51.96
Exchange Differences	-	(0.44)	(0.39)	(0.04)	(0.10)	(0.97)
<b>As at 31 March 2019</b>	<b>1.68</b>	<b>37.14</b>	<b>9.17</b>	<b>0.65</b>	<b>2.35</b>	<b>50.99</b>
Ind AS 116 transition adjustment	(1.68)	(37.14)	(9.17)	(0.65)	(2.35)	(50.99)
<b>As at 1 April 2019</b>	-	-	-	-	-	-
Charge for the year #	1.68	45.32	17.03	2.04	4.77	70.84
Assets disposed/ discarded during the year	-	(0.05)	-	-	-	(0.05)
Exchange Differences	-	(0.46)	(0.99)	(0.11)	(0.24)	(1.80)
<b>As at 31 March 2020</b>	<b>1.68</b>	<b>44.81</b>	<b>16.04</b>	<b>1.93</b>	<b>4.53</b>	<b>68.99</b>
<b>As at 1 April 2020</b>	<b>1.68</b>	<b>44.81</b>	<b>16.04</b>	<b>1.93</b>	<b>4.53</b>	<b>68.99</b>
Charge for the year #	1.68	44.44	30.99	4.92	6.04	88.07
Assets disposed/ discarded during the year	-	-	(1.24)	-	(0.14)	(1.38)
Exchange Differences	-	3.01	2.96	0.23	0.82	7.02
<b>As at 31 March 2021</b>	<b>3.36</b>	<b>92.26</b>	<b>48.75</b>	<b>7.08</b>	<b>11.25</b>	<b>162.70</b>
<b>As at 1 April 2021</b>	<b>3.36</b>	<b>92.26</b>	<b>48.75</b>	<b>7.08</b>	<b>11.25</b>	<b>162.70</b>
Charge for the period #	0.42	10.16	10.49	1.26	1.57	23.90
Assets disposed/ discarded during the period	-	-	(14.95)	-	-	(14.95)
Exchange Differences	-	0.22	0.52	0.12	0.28	1.14
<b>As at 30 June 2021</b>	<b>3.78</b>	<b>102.64</b>	<b>44.81</b>	<b>8.46</b>	<b>13.10</b>	<b>172.79</b>
<b>Net Carrying Value</b>						
<b>As at 31 March 2019</b>	<b>87.43</b>	<b>95.00</b>	<b>194.67</b>	<b>4.24</b>	<b>4.51</b>	<b>385.85</b>
<b>As at 31 March 2020</b>	<b>85.76</b>	<b>65.41</b>	<b>225.88</b>	<b>17.18</b>	<b>11.63</b>	<b>405.86</b>
<b>As at 31 March 2021</b>	<b>84.08</b>	<b>255.32</b>	<b>230.34</b>	<b>12.71</b>	<b>8.56</b>	<b>591.01</b>
<b>As at 30 June 2021</b>	<b>83.66</b>	<b>251.82</b>	<b>251.59</b>	<b>11.59</b>	<b>8.88</b>	<b>607.54</b>

\*Includes INR 7.60 Mn and INR 87.95 Mn which has been reclassified from Property plant and equipment and prepaid rent respectively on adoption of Ind AS 116.

\*\*Includes INR 2.49 Mn and INR 88.60 Mn which has been reclassified from Property plant and equipment and prepaid rent respectively on adoption of Ind AS 116.

# Included under Depreciation and Amortisation expense (Refer Note 35)

(e) Following are the changes in carrying value of lease liabilities

Particulars	Amount
<b>Opening Balance as at 1 April 2018</b>	<b>340.75</b>
Additions during the year	14.94
Finance costs during the year	29.23
Lease payments during the year	(65.65)
Exchange Differences	(11.08)
<b>Closing Balance as at 31 March 2019</b>	<b>308.19</b>
Ind AS 116 transition adjustment	(63.45)
<b>Opening Balance as at 1 April 2019</b>	<b>244.74</b>
Additions during the year	171.30
Finance costs during the year	25.71
Lease terminated during the year	(0.52)
Lease payments during the year	(79.27)
Exchange Differences	(21.26)
<b>Closing Balance as at 31 March 2020</b>	<b>340.70</b>
<b>Opening Balance as at 1 April 2020</b>	<b>340.70</b>
Additions during the year	24.96
Finance costs during the year	26.52
Lease terminated during the year	(1.25)
Rent waiver on Lease Liabilities	(1.39)
Lease payments during the year	(103.84)
Exchange Differences	33.00
<b>Closing Balance as at 31 March 2021</b>	<b>318.70</b>
<b>Opening Balance as at 1 April 2021</b>	<b>318.70</b>
Additions during the period	37.58
Finance costs during the period	6.54
Rent waiver on Lease Liabilities	(0.06)
Lease payments during the period	(28.42)
Exchange Differences	3.12
<b>Closing Balance as at 30 June 2021</b>	<b>337.46</b>

**(f) Amounts recognised in Restated Consolidated Statement of Assets and Liabilities**

The Restated Consolidated Statement of Assets and Liabilities shows the following amounts relating to leases:

Particulars	30 June 2021	31 March 2021	31 March 2020	31 March 2019
<b>Right-of-use assets</b>				
Land	83.66	84.08	85.76	87.43
Buildings	251.82	255.32	65.41	95.00
Plant and equipment	251.59	230.34	225.88	194.67
Office Equipment	11.59	12.71	17.18	4.24
Vehicle	8.88	8.56	11.63	4.51
<b>Total</b>	<b>607.54</b>	<b>591.01</b>	<b>405.86</b>	<b>385.85</b>

Particulars	30 June 2021	31 March 2021	31 March 2020	31 March 2019
<b>Lease Liabilities</b>				
Current	75.57	80.89	92.81	64.56
Non-Current	261.89	237.81	247.89	243.63
<b>Total</b>	<b>337.46</b>	<b>318.70</b>	<b>340.70</b>	<b>308.19</b>

**(g) Amounts recognised in the Restated Consolidated Statement of Profit and Loss**

The Restated Consolidated Statement of Profit and Loss shows the following amounts relating to leases:

Particulars	30 June 2021	31 March 2021	31 March 2020	31 March 2019
a. Depreciation charge of right-of-use assets (Refer Note 35)	23.90	88.07	70.84	51.96
b. Interest expense (included in finance costs) (Refer Note 34)	6.54	26.52	25.71	29.23
c. Expenses relating to short-term leases (included in other expenses) (Refer Note 36)	4.01	6.15	11.12	20.80
<b>Total</b>	<b>34.45</b>	<b>120.74</b>	<b>107.67</b>	<b>101.99</b>

**(h)** The Group had a total cash outflow of INR 28.42 Mn for leases for the period ended 30 June 2021 (31 March 2021: INR 103.84 Mn ; 31 March 2020: INR 79.27 Mn and 31 March 2019: INR 65.65 Mn)

**(i) Extension and termination options**

Extension and termination options are included in the Group's lease contracts. These are used to maximise operational flexibility in terms of managing the assets used in the Group's operations. In majority of the lease contracts, the extension and termination options held are exercisable by mutual consent of both the lessor and the lessee and in few contracts, the option to terminate the lease is with lessee only.

For determining the lease term Land, Plant & Machinery, office Space and Office Equipments, the following factors are normally the most relevant:

- If there are significant penalty payments to terminate (or not extend), the group is typically reasonably certain to extend (or not terminate).
- If any leasehold improvements are expected to have a significant remaining value, the group is typically reasonably certain to extend (or not terminate).
- Otherwise, the group considers other factors including historical lease durations and the costs and business disruption required to replace the leased asset.

During the year ended 31 March 2021, the holding company has entered into a long-term lease for an office space which contains further renewal options and only the holding company can terminate the lease giving 6 months notice. Considering the above factors, the termination option with the holding company and the expected period of use, the lease term has been determined as 60 years which is shorter than the contractual duration.

**(j) Residual value guarantees**

There are no residual value guarantees in relation to any lease contracts.

Note 3(c): Capital work-in-progress

Particulars	a	b	c	d	e= (a+b+c+d)
	As at 1 April 2018	Addition	Capitalisation/ Adjustments	Exchange Differences	As at 31 March 2019
Capital work-in-progress	18.00	1.75	(3.33)	-	16.42

Particulars	a	b	c	d	e= (a+b+c+d)
	As at 1 April 2019	Addition	Capitalisation/ Adjustments	Exchange Differences	As at 31 March 2020
Capital work-in-progress	16.42	100.60	(54.80)	-	62.22

Particulars	a	b	c	d	e= (a+b+c+d)
	As at 1 April 2020	Addition	Capitalisation/ Adjustments	Exchange Differences	As at 31 March 2021
Capital work-in-progress	62.22	89.79	(84.15)	0.73	68.59

Particulars	a	b	c	d	e= (a+b+c+d)
	As at 1 April 2021	Addition	Capitalisation/ Adjustments	Exchange Differences	As at 30 June 2021
Capital work-in-progress	68.59	27.40	(25.34)	0.39	71.04

(i) Capital work-in-progress (CWIP) ageing schedule as at 31 March 2019:

Particulars	Amount in CWIP for a period of				Total
	Less than 1 year	1-2 years	2-3 years	More than 3 years	
Projects in progress	2.52	4.87	0.29	8.74	16.42
Projects temporarily suspended	-	-	-	-	-
<b>Total</b>	<b>2.52</b>	<b>4.87</b>	<b>0.29</b>	<b>8.74</b>	<b>16.42</b>

Capital work-in-progress for which completion is overdue or has exceeded its cost compared to its original plan as at 31 March 2019:

Particulars	To be completed in				Total
	Less than 1 Year	1-2 Years	2-3 Years	More than 3 Years	
Hardox Preheating Oven	0.92	-	-	-	0.92
Centrex and Alignex Project	1.08	-	-	-	1.08
<b>Total</b>	<b>2.00</b>	<b>-</b>	<b>-</b>	<b>-</b>	<b>2.00</b>

(ii) Capital work-in-progress (CWIP) ageing schedule as at 31 March 2020:

Particulars	Amount in CWIP for a period of				Total
	Less than 1 year	1-2 years	2-3 years	More than 3 years	
Projects in progress	56.65	1.08	0.35	4.14	62.22
Projects temporarily suspended	-	-	-	-	-
<b>Total</b>	<b>56.65</b>	<b>1.08</b>	<b>0.35</b>	<b>4.14</b>	<b>62.22</b>

Capital work-in-progress for which completion is overdue or has exceeded its cost compared to its original plan as at 31 March 2020:

Particulars	To be completed in				Total
	Less than 1 Year	1-2 Years	2-3 Years	More than 3 Years	
Painting Booth	7.55	-	-	-	7.55
<b>Total</b>	<b>7.55</b>	<b>-</b>	<b>-</b>	<b>-</b>	<b>7.55</b>

(iii) Capital work-in-progress (CWIP) ageing schedule as at 31 March 2021:

Particulars	Amount in CWIP for a period of				Total
	Less than 1 year	1-2 years	2-3 years	More than 3 years	
Projects in progress	64.10	1.72	0.03	2.74	68.59
Projects temporarily suspended	-	-	-	-	-
<b>Total</b>	<b>64.10</b>	<b>1.72</b>	<b>0.03</b>	<b>2.74</b>	<b>68.59</b>

Capital work-in-progress for which completion is overdue or has exceeded its cost compared to its original plan as at 31 March 2021:

Particulars	To be completed in				Total
	Less than 1 Year	1-2 Years	2-3 Years	More than 3 Years	
Audio Visual System	1.12	-	-	-	1.12
Banbury RAM Cylinder	4.80	-	-	-	4.80
Boiler Feed Water Tank	7.68	-	-	-	7.68
Diesel Driven Pump and Hydrant Line Extension	4.37	-	-	-	4.37
Eot Crane 15T and Semi Goliath Crane 5T	0.17	-	-	-	0.17
Plant Back Side Plot Filling	1.71	-	-	-	1.71
Replacement of Autoclave 3m Diameter	0.04	-	-	-	0.04
Stock Blender Assembly on Mixing Mill	1.16	-	-	-	1.16
Toluene Storage Tank	1.46	-	-	-	1.46
<b>Total</b>	<b>22.51</b>	<b>-</b>	<b>-</b>	<b>-</b>	<b>22.51</b>

(iv) Capital work-in-progress (CWIP) ageing schedule as at 30 June 2021:

Particulars	Amount in CWIP for a period of				Total
	Less than 1 year	1-2 years	2-3 years	More than 3 years	
Projects in progress	63.57	6.56	0.07	0.84	71.04
Projects temporarily suspended	-	-	-	-	-
<b>Total</b>	<b>63.57</b>	<b>6.56</b>	<b>0.07</b>	<b>0.84</b>	<b>71.04</b>

Capital work-in-progress for which completion is overdue or has exceeded its cost compared to its original plan as at 30 June 2021:

Particulars	To be completed in				Total
	Less than 1 Year	1-2 Years	2-3 Years	More than 3 Years	
Audio Visual System	1.30	-	-	-	1.30
Banbury RAM Cylinder	4.81	-	-	-	4.81
Bolier Feed Water Tank	7.71	-	-	-	7.71
Diesel Driven Pump and Hydrant Line Extension	4.38	-	-	-	4.38
Eot Crane 15T and Semi Goliath Crane 5T	5.02	-	-	-	5.02
Plant Back Side Plot Filling	1.80	-	-	-	1.80
Replacement of Autoclave 3m Diameter	0.04	-	-	-	0.04
Stock Blender Assembly on Mixing Mill	1.16	-	-	-	1.16
Toluene Storage Tank	1.46	-	-	-	1.46
<b>Total</b>	<b>27.68</b>	<b>-</b>	<b>-</b>	<b>-</b>	<b>27.68</b>

Note 3(d): Other intangible assets

Particulars	Computer software	Total
<b>Gross Block</b>		
<b>As at 1 April 2018</b>	<b>20.82</b>	<b>20.82</b>
Additions during the year	7.90	7.90
Disposals/ Adjustments during the year	1.14	1.14
Exchange Differences	(0.06)	(0.06)
<b>As at 31 March 2019</b>	<b>27.52</b>	<b>27.52</b>
<b>As at 1 April 2019</b>	<b>27.52</b>	<b>27.52</b>
Additions during the year	1.85	1.85
Disposals/ Adjustments during the year	-	-
Exchange Differences	(0.31)	(0.31)
<b>As at 31 March 2020</b>	<b>29.06</b>	<b>29.06</b>
<b>As at 1 April 2020</b>	<b>29.06</b>	<b>29.06</b>
Additions during the year	8.50	8.50
Disposals/ Adjustments during the year	-	-
Exchange Differences	0.61	0.61
<b>As at 31 March 2021</b>	<b>38.17</b>	<b>38.17</b>
<b>As at 1 April 2021</b>	<b>38.17</b>	<b>38.17</b>
Additions during the period	12.52	12.52
Disposals/ Adjustments during the period	-	-
Exchange Differences	(0.02)	(0.02)
<b>As at 30 June 2021</b>	<b>50.67</b>	<b>50.67</b>
<b>Accumulated Depreciation</b>		
<b>As at 1 April 2018</b>	<b>15.80</b>	<b>15.80</b>
Charge for the year	5.36	5.36
Disposals/ Adjustments during the year	1.01	1.01
Exchange Differences	(0.06)	(0.06)
<b>As at 31 March 2019</b>	<b>20.09</b>	<b>20.09</b>
<b>As at 1 April 2019</b>	<b>20.09</b>	<b>20.09</b>
Charge for the year	3.82	3.82
Disposals/ Adjustments during the year	-	-
Exchange Differences	(0.19)	(0.19)
<b>As at 31 March 2020</b>	<b>23.72</b>	<b>23.72</b>
<b>As at 1 April 2020</b>	<b>23.72</b>	<b>23.72</b>
Charge for the year	6.94	6.94
Disposals/ Adjustments during the year	-	-
Exchange Differences	0.38	0.38
<b>As at 31 March 2021</b>	<b>31.04</b>	<b>31.04</b>
<b>As at 1 April 2021</b>	<b>31.04</b>	<b>31.04</b>
Charge for the period	1.48	1.48
Disposals/ Adjustments during the period	-	-
Exchange Differences	0.06	0.06
<b>As at 30 June 2021</b>	<b>32.58</b>	<b>32.58</b>
<b>Net Carrying Value</b>		
<b>As at 31 March 2019</b>	<b>7.43</b>	<b>7.43</b>
<b>As at 31 March 2020</b>	<b>5.34</b>	<b>5.34</b>
<b>As at 31 March 2021</b>	<b>7.13</b>	<b>7.13</b>
<b>As at 30 June 2021</b>	<b>18.09</b>	<b>18.09</b>

Note 3(e): Intangible assets under development

Particulars	a	b	c	d	e= (a+b+c+d)
	As at 1 April 2018	Addition	Capitalisation/ Adjustments	Exchange Differences	As at 31 March 2019
Intangible assets under development	31.79	3.07	(10.93)	-	23.93

Particulars	a	b	c	d	e= (a+b+c+d)
	As at 1 April 2019	Addition	Capitalisation/ Adjustments	Exchange Differences	As at 31 March 2020
Intangible assets under development	23.93	-	-	-	23.93

Particulars	a	b	c	d	e= (a+b+c+d)
	As at 1 April 2020	Addition	Capitalisation/ Adjustments	Exchange Differences	As at 31 March 2021
Intangible assets under development	23.93	-	(23.93)	-	-

Particulars	a	b	c	d	e= (a+b+c+d)
	As at 1 April 2021	Addition	Capitalisation/ Adjustments	Exchange Differences	As at 30 June 2021
Intangible assets under development	-	-	-	-	-

(i) Intangible assets under development ageing schedule as at 31 March 2019:

Particulars	Amount in Intangible assets under development for a period of				Total
	Less than 1 year	1-2 years	2-3 years	More than 3 years	
Projects in progress	3.07	-	-	-	3.07
Projects temporarily suspended	-	-	6.58	14.28	20.86
<b>Total</b>	<b>3.07</b>	<b>-</b>	<b>6.58</b>	<b>14.28</b>	<b>23.93</b>

Intangible assets under development for which completion is overdue or has exceeded its cost compared to its original plan as at 31 March 2019:

Particulars	To be completed in				Total
	Less than 1 year	1-2 years	2-3 years	More than 3 years	
<b>Projects temporarily suspended</b>					
Technical Knowhow for Slurry Pumps	-	-	20.86	-	20.86
<b>Total</b>	<b>-</b>	<b>-</b>	<b>20.86</b>	<b>-</b>	<b>20.86</b>

(ii) Intangible assets under development ageing schedule as at 31 March 2020:

Particulars	Amount in Intangible assets under development for a period of				Total
	Less than 1 year	1-2 years	2-3 years	More than 3 years	
Projects in progress	-	-	-	-	-
Projects temporarily suspended	-	3.07	-	20.86	23.93
<b>Total</b>	<b>-</b>	<b>3.07</b>	<b>-</b>	<b>20.86</b>	<b>23.93</b>

Intangible assets under development for which completion is overdue or has exceeded its cost compared to its original plan as at 31 March 2020:

Particulars	To be completed in				Total
	Less than 1 year	1-2 years	2-3 years	More than 3 years	
<b>Projects temporarily suspended</b>					
Technical Knowhow for Slurry Pumps	-	20.86	-	-	20.86
Technical Knowhow for Centrix and Alignx	3.07	-	-	-	3.07
<b>Total</b>	<b>3.07</b>	<b>20.86</b>	<b>-</b>	<b>-</b>	<b>23.93</b>

**Note: 4 Investment property**

Particulars	30 June 2021	31 March 2021	31 March 2020	31 March 2019
Land	40.56	38.49	33.01	37.21
<b>Total</b>	<b>40.56</b>	<b>38.49</b>	<b>33.01</b>	<b>37.21</b>

**Fair value of Group's Investment property**

The Group has identified its unsecured freehold land at Farm number 110, portion 224, Klippoortjie, Gauteng, South Africa held under title deed number T38235/2009 as investment property. The fair valuation of the property is done by SAIV (31 March 2021: SAIV; 31 March 2020 and 31 March 2019: C2C Property Valuations), Independent valuer and appraiser for the Master of the Supreme Court (Pretoria) and has the appropriate qualifications and recent experience in the fair value measurement of properties in the relevant locations. Details of the fair value of the group investment property as at 30 June 2021, 31 March 2021, 31 March 2020 and 31 March 2019 are given below:

Particulars	Fair Value 30 June 2021	Fair Value 31 March 2021	Fair Value 31 March 2020	Fair Value 31 March 2019
Land	40.56	38.49	33.01	37.21
<b>Total</b>	<b>40.56</b>	<b>38.49</b>	<b>33.01</b>	<b>37.21</b>

Fair Value measurement of Investment property is included in Level-3 hierarchy.

**Note: 5 Goodwill**

Particulars	30 June 2021	31 March 2021	31 March 2020	31 March 2019
Goodwill on consolidation	633.92	632.82	523.64	557.46

**Movement in balances**

Particulars	30 June 2021	31 March 2021	31 March 2020	31 March 2019
Cost as at beginning of the period/ year	632.82	523.64	557.46	575.93
Less: Adjustment arising on disposal of subsidiaries	-	-	-	(5.88)
Add/ less: Exchange difference during the period/ year on translation of Goodwill of foreign subsidiaries	1.10	109.18	(33.82)	(12.59)
<b>Cost as at end of the period/ year</b>	<b>633.92</b>	<b>632.82</b>	<b>523.64</b>	<b>557.46</b>
<b>Net carrying value as at beginning of the period/ year</b>	<b>632.82</b>	<b>523.64</b>	<b>557.46</b>	<b>575.93</b>
<b>Net carrying value as at end of the period/ year</b>	<b>633.92</b>	<b>632.82</b>	<b>523.64</b>	<b>557.46</b>

The goodwill is attributable to the manufacturing entities in Australia and South Africa. The carrying amount of goodwill for such entities are INR 627.08 Mn (31 March 2021: INR 626.32 Mn ; 31 March 2020: INR 518.07 Mn and 31 March 2019: INR 551.18 Mn) and INR 6.84 Mn (31 March 2021: INR 6.50 Mn ; 31 March 2020: INR 5.57 Mn and 31 March 2019: INR 6.28 Mn) respectively.

The Group has adopted 'value in use' method to determine the carrying value of cash generating unit. The calculations use cash flow projections based on financial budgets approved by the management for the next financial year, and projections are further made for a period of four years. Cash flow beyond these periods are extrapolated using the estimated growth rates. The key assumptions used by the management are revenue growth rate and discount rate.

The base assumptions considered for testing the goodwill impairment for both the cash generating units are as follows:

- The discounting rate (Post tax) has been taken at 13.00% (31 March 2021: 12.80% ; 31 March 2020: 13.50% and 31 March 2019: 13.00%) for Australia and 17.40% (31 March 2021: 17.60% ; 31 March 2020: 15.00% and 31 March 2019: 10.79%) for South Africa.
- The long term growth rate has been taken at 2.50% (31 March 2021: 2.50% ; 31 March 2020: 2.00% and 31 March 2019: 1.90%) for Australia and 3.00% (31 March 2021: 3.00% ; 31 March 2020: 2.00% and 31 March 2019: 4.00%) for South Africa.
- Tax rate has been taken as 30.00% (31 March 2021: 30.00% ; 31 March 2020: 30.00% and 31 March 2019: 30.00%) for Australia and 28.00% (31 March 2021: 28.00% ; 31 March 2020: 28.00% and 31 March 2019: 28.00%) for South Africa.

Management has determined the values assigned to each of the above key assumptions as follows:

**Revenue growth rate**

Average annual growth rate over the five-year forecast period; based on past performance and management's expectations of market development and current industry trends including long-term inflation forecasts for each territory.

**Long-term growth rate**

This is the weighted average growth rate used to extrapolate cash flows beyond the budget period. The rates are consistent with forecasts included in industry reports.

**Post-tax discount rates**

Reflect specific risks relating to the relevant segments and the countries in which they operate.

**Other key assumptions**

Other key assumptions considered by the management are the costs which are largely dependent on the revenues and accordingly any change in revenue projections will also impact the costs similarly.

As a result of the above test for impairment the recoverable amount of the CGUs exceeded the carrying value of the CGUs.

Goodwill in the Restated Consolidated Financial Information primarily consists of goodwill in manufacturing entity in Australia. The recoverable amount of manufacturing entity in Australia (CGU) would equal its carrying amount if the key assumptions were to change as follows:

Particulars	30 June 2021		31 March 2021		31 March 2020		31 March 2019	
	From	To	From	To	From	To	From	To
Long-term growth rate (%)	2.50%	1.51%	2.50%	1.72%	2.00%	0.10%	1.90%	-4.00%
Post-tax discount rate (%)	13.00%	13.75%	12.80%	13.36%	13.50%	14.79%	13.00%	16.64%

**Note: 6 Investments - non current**

Particulars	30 June 2021	31 March 2021	31 March 2020	31 March 2019
<b>I. Measured at FVTPL</b>				
<b>Quoted</b>				
<b>Investments in Mutual Funds</b>				
ICICI Prudential Fixed Maturity Plan Series 85-1156 days Plan Growth Direct Plan <sup>^</sup> #	-	60.62	55.64	50.51
NIL units (31 March 2021: 5,000,000 units; 31 March 2020: 5,000,000 units and 31 March 2019: 5,000,000 units)				
IDFC Fixed term Plan Series 177 Direct Plan Growth-1160 days <sup>^</sup> #	-	85.13	77.81	70.69
NIL units (31 March 2021: 7,000,000 units; 31 March 2020: 7,000,000 units and 31 March 2019: 7,000,000 units)				
Mirae Asset Fixed Maturity Plan Series III-1122 days-Direct Plan Growth <sup>^</sup> #	-	36.10	33.13	30.19
NIL units (31 March 2021: 3,000,000 units; 31 March 2020: 3,000,000 units and 31 March 2019: 3,000,000 units)				
<b>Total</b>	<b>-</b>	<b>181.85</b>	<b>166.58</b>	<b>151.39</b>

<sup>^</sup> Marked under lien in favour of lenders for securing borrowings as at 31 March 2021

<sup>#</sup> Marked under lien in favour of lenders for secured borrowings as at 31 March 2020

<b>Aggregate amount of quoted investments</b>	-	181.85	166.58	151.39
<b>Aggregate market value of quoted investments</b>	-	181.85	166.58	151.39



**Note: 7 Other financial assets - non current**

Particulars	30 June 2021	31 March 2021	31 March 2020	31 March 2019
<b>Unsecured, considered good (unless otherwise stated)</b>				
Security Deposits	19.26	18.68	25.34	31.82
<b>Other bank balances</b>				
Earmarked accounts				
In deposit account*	5.94	8.28	12.24	5.24
Derivative assets	75.18	76.05	89.70	22.15
<b>Total</b>	<b>100.38</b>	<b>103.01</b>	<b>127.28</b>	<b>59.21</b>

\*INR 1.32 Mn (31 March 2021: INR 1.53 Mn ; 31 March 2020: INR 5.92 Mn and 31 March 2019: INR 1.33 Mn) Lodged as security against bank guarantee.

**Note: 8 Non-current tax assets (net)**

Particulars	30 June 2021	31 March 2021	31 March 2020	31 March 2019
Advance Income Tax (Net of Provision for Income Tax)	105.41	101.82	79.83	84.97
<b>Total</b>	<b>105.41</b>	<b>101.82</b>	<b>79.83</b>	<b>84.97</b>

**Note: 9 Deferred tax assets (net)**

Particulars	30 June 2021	31 March 2021	31 March 2020	31 March 2019
<b>The balance comprises temporary differences attributable to:</b>				
<b>Deferred tax assets</b>				
Allowance for doubtful debts and advances	33.67	42.03	56.32	30.73
Accumulated losses *	146.90	125.82	207.83	-
Amounts allowable for tax purpose on payment basis	7.76	8.18	48.64	8.16
Property, plant and equipment and Intangible assets	-	0.84	-	-
Lease liabilities	80.58	73.18	92.76	62.01
Other temporary difference	74.94	73.26	62.10	57.49
<b>Total</b>	<b>343.85</b>	<b>323.31</b>	<b>467.65</b>	<b>158.39</b>
<b>Deferred tax liabilities</b>				
Property, plant and equipment and Intangible assets	0.03	-	58.38	8.05
Fair valuation of investment	-	-	7.44	-
Right-of-Use assets	74.08	67.03	94.02	60.10
<b>Total</b>	<b>74.11</b>	<b>67.03</b>	<b>159.84</b>	<b>68.15</b>
<b>Deferred tax assets (net)</b>	<b>269.74</b>	<b>256.28</b>	<b>307.81</b>	<b>90.24</b>

Refer note 37 for tax expenses

\* absorption expected based on future taxable income

**Note: 10 Other non-current assets**

Particulars	30 June 2021	31 March 2021	31 March 2020	31 March 2019
<b>Unsecured, considered good</b>				
Capital advances	23.65	13.29	8.05	21.99
Prepaid expenses	0.60	0.77	0.89	0.58
<b>Total</b>	<b>24.25</b>	<b>14.06</b>	<b>8.94</b>	<b>22.57</b>

**Note: 11 Inventories**

Particulars	30 June 2021	31 March 2021	31 March 2020	31 March 2019
Raw materials [including Goods in transit INR 104.90 Mn (31 March 2021: INR 58.17 Mn ; 31 March 2020: INR 11.93 Mn and 31 March 2019: INR 20.70 Mn)]	1,142.61	777.95	621.66	579.06
Work-in-progress	205.89	230.69	197.60	152.51
Finished goods	581.36	469.47	406.74	358.88
Stores and spares [Includes Goods in transit INR 4.29Mn (31 March 2021: INR 1.82 Mn ; 31 March 2020: INR 1.16 Mn and 31 March 2019: INR NIL)]	148.80	108.20	100.30	120.13
<b>Total</b>	<b>2,078.66</b>	<b>1,586.31</b>	<b>1,326.30</b>	<b>1,210.58</b>

**Note:**

(i) The Group has expensed inventory of INR (1.02) Mn (31 March 2021: INR 52.91 Mn ; 31 March 2020: INR 49.46 Mn and 31 March 2019: INR (8.97) Mn) for writing down the value of inventories towards slow moving, non-moving and obsolete inventory.

(ii) The mode of valuation of inventories has been stated in Note 2.12

(iii) Inventories have been pledged to secure borrowings of the group, wherever applicable. (Refer Note 20 and 23)

**Note: 12 Investments - current**

Particulars	30 June 2021	31 March 2021	31 March 2020	31 March 2019
<b>I. Measured at FVTPL</b>				
<b>Investments in Mutual Funds</b>				
<b>Quoted</b>				
ICICI Prudential Fixed Maturity Plan Series 85-1156 days Plan G Direct Plan@ 5,000,000 units (31 March 2021: NIL units; 31 March 2020: NIL units and 31 March 2019: NIL units)	61.30	-	-	-
IDFC Fixed term Plan Series 177 Direct Plan Growth-1160 days@ 7,000,000 units (31 March 2021: NIL units; 31 March 2020: NIL units and 31 March 2019: NIL units)	86.08	-	-	-
Mirae Asset Fixed Maturity Plan Series III-1122 days-Direct Growth@ 3,000,000 units (31 March 2021: NIL units; 31 March 2020: NIL units and 31 March 2019: NIL units)	36.50	-	-	-
<b>Unquoted</b>				
Aditya Birla Sun Life Corporate Bond Fund- Direct Plan- Growth 866,995 units (31 March 2021: 866,995 units ; 31 March 2020: 518,905 units and 31 March 2019: NIL units)	76.37	75.20	40.93	-
Aditya Birla Sun Life Liquid Fund-Direct Plan- IDCW- Daily NIL units (31 March 2021: NIL units ; 31 March 2020: 958,578 units and 31 March 2019: NIL units)	-	-	96.04	-
Aditya Birla Sun Life Banking and PSU Debt Fund- Direct Plan- Growth 152,462 units (31 March 2021: 152,462 units ; 31 March 2020: 152,462 units and 31 March 2019: NIL units)	44.85	44.17	40.70	-
Aditya Birla Sun Life Money Manager Fund 242,320 units (31 March 2021: NIL units; 31 March 2020: NIL units and 31 March 2019: NIL units)	70.28	-	-	-
Aditya Birla Sun Life Savings Fund- Direct Plan- Growth# NIL units (31 March 2021: NIL units ; 31 March 2020: 67,502 units and 31 March 2019: 67,502 units)	-	-	27.06	25.09
Axis Treasury Advantage Fund- Direct Growth@^# 19,522 units (31 March 2021: 12,322 units; 31 March 2020: 12,322 units and 31 March 2019: NIL units)	49.00	30.59	28.65	-
Axis Short Term Fund- Direct Plan- Growth 6,111,231 units (31 March 2021: 6,111,231 units; 31 March 2020: NIL units and 31 March 2019: NIL units)	157.41	155.24	-	-
Axis Liquid Fund - Direct Growth 8,707 units (31 March 2021: NIL units ; 31 March 2020: 90,685 units and 31 March 2019: NIL units)	20.06	-	90.77	-
DSP Banking & PSU Debt Fund- Direct Plan- Growth 1,715,129 units (31 March 2021: 1,715,129 units; 31 March 2020: 1,715,129 units and 31 March 2019: NIL units)	33.25	32.90	30.38	-
DSP Low Duration Fund-Direct Plan- Growth 973,263 units (31 March 2021: 973,263 units; 31 March 2020: NIL units and 31 March 2019: NIL units)	15.55	15.40	-	-
DSP Saving Fund-Direct Plan- Growth 2,924 units (31 March 2021: 1,189,187 units ; 31 March 2020: NIL units and 31 March 2019: NIL units)	0.12	50.07	-	-
DSP Ultra Short Fund-Direct Plan- Growth 42,402 units (31 March 2021: 65,104 units ; 31 March 2020: NIL units and 31 March 2019: NIL units)	122.10	185.83	-	-
Franklin India Liquid Fund - Super Institutional Plan- Direct NIL units (31 March 2021: NIL units; 31 March 2020: NIL units and 31 March 2019: 45,135 units)	-	-	-	45.24
Franklin India Short Term Income Plan - Retail Plan Growth* NIL units (31 March 2021: NIL units; 31 March 2020: NIL units and 31 March 2019: 37,000 units)	-	-	-	147.90
HDFC Corporate Bond Fund- Direct Plan- Growth@^# 3,195,709 units (31 March 2021: 3,195,709 units; 31 March 2020: 2,196,239 units and 31 March 2019: NIL units)	81.70	80.48	50.70	-
HDFC Liquid Plan-Direct Plan- Growth NIL units (31 March 2021: NIL units; 31 March 2020: 74,207 units and 31 March 2019: NIL units)	-	-	75.68	-
ICICI Prudential Liquid Fund - Institutional- Dividend- Daily NIL units (31 March 2021: NIL units; 31 March 2020: 521,740 units and 31 March 2019: NIL units)	-	-	52.23	-
ICICI Prudential Overnight Fund- Regular Plan- Growth NIL units (31 March 2021: NIL units; 31 March 2020: 2,150,968 units and 31 March 2019: NIL units )	-	-	215.10	-
ICICI Prudential Short Term Fund- Direct Fund- Growth 1,133,953 units (31 March 2021: 1,133,953 units; 31 March 2020: 1,133,953 units and 31 March 2019: NIL units)	55.99	55.13	50.31	-
ICICI Prudential Ultra Short Term Fund-Growth 5,705,071 units (31 March 2021: 6,141,689 units; 31 March 2020: NIL units and 31 March 2019: NIL units)	132.08	140.51	-	-
ICICI Prudential Savings Fund - Direct Plan- Growth@^# 69,502 units (31 March 2021: 69,502 units; 31 March 2020: 69,502 units and 31 March 2019: 69,502 units)	29.57	29.17	27.13	25.10
ICICI Prudential Liquid Fund - Direct Plan - Daily Dividend NIL units (31 March 2021: NIL units; 31 March 2020: NIL units and 31 March 2019: 1,550 units)	-	-	-	0.16
IDFC Bond Fund-Short Term- Direct Plan- Growth 698,262 units (31 March 2021: 698,262 units; 31 March 2020: 698,262 units and 31 March 2019: NIL units)	33.12	32.72	30.28	-
IDFC Low Duration Fund- Direct Plan- Growth@^ 845,823 units (31 March 2021: 845,823 units; 31 March 2020: NIL units and 31 March 2019: NIL units)	26.19	25.93	-	-
IDFC Corporate Bond Fund- Direct Plan- Growth 5,451,773 units (31 March 2021: 5,451,773 units; 31 March 2020: NIL units and 31 March 2019: NIL units)	84.43	83.24	-	-

**Note: 12 Investments - current**

Particulars	30 June 2021	31 March 2021	31 March 2020	31 March 2019
Kotak Corporate Bond Fund- Direct Plan- Growth@^# 32,296 units (31 March 2021: 32,296 units ; 31 March 2020: 7,945 units and 31 March 2019: 7,945 units)	97.73	96.39	21.93	20.08
Kotak Banking and PSU Debt Fund-Direct Plan- Growth@^# 1,075,722 units (31 March 2021: 1,075,722 units; 31 March 2020: 1,075,722 units and 31 March 2019: NIL units)	56.33	55.43	51.25	-
Kotak Bond Short Term Plan-Direct Plan-Growth@^# 1,276,236 units (31 March 2021: 1,276,236 units; 31 March 2020: 1,276,236 units and 31 March 2019: NIL units)	56.31	55.49	51.19	-
Kotak Savings Fund -Direct Plan- Growth 3,324,721 units (31 March 2021: 1,600,535 units; 31 March 2020: NIL units and 31 March 2019: NIL units)	116.35	55.51	-	-
Nippon India Banking & PSU Debt Fund- Direct Growth Plan 8,211,606 units (31 March 2021: 8,211,606 units; 31 March 2020: NIL units and 31 March 2019: NIL units)	136.78	134.84	-	-
Nippon India Liquid Fund - Direct Growth Plan 3,953 units (31 March 2021: NIL units; 31 March 2020: NIL units and 31 March 2019: NIL units)	20.06	-	-	-
Nippon India Money Market Fund - Direct Growth Plan 15,417 units (31 March 2021: NIL units; 31 March 2020: NIL units and 31 March 2019: NIL units)	50.12	-	-	-
Reliance Credit Risk Fund -Growth Plan- Growth Option* NIL units (31 March 2021: NIL units; 31 March 2020: NIL units and 31 March 2019: 4,600,000 units)	-	-	-	118.58
SBI Banking & PSU Fund- Direct Plan- Growth@^# 49,992 units (31 March 2021: 49,992 units; 31 March 2020: 21,657 units and 31 March 2019: NIL units)	129.35	127.68	51.23	-
SBI Overnight Fund- Regular Plan- Growth NIL units (31 March 2021: NIL units; 31 March 2020: 133,748 units and 31 March 2019: NIL units)	-	-	135.07	-
<b>Total</b>	<b>1,878.98</b>	<b>1,561.92</b>	<b>1,166.63</b>	<b>382.15</b>
@ Marked under lien in favour of lenders for secured borrowings as at 30 June 2021				
^ Marked under lien in favour of lenders for secured borrowings as at 31 March 2021				
# Marked under lien in favour of lenders for secured borrowings as at 31 March 2020				
* Marked under lien in favour of lenders for secured borrowings as at 31 March 2019				
<b>Aggregate amount of quoted Investments</b>	<b>183.88</b>	-	-	-
<b>Aggregate market value of quoted investments</b>	<b>183.88</b>	-	-	-
<b>Aggregate amount of unquoted investments</b>	<b>1,695.10</b>	<b>1,561.92</b>	<b>1,166.63</b>	<b>382.15</b>

**Note: 13 Trade receivables and contract assets**

Particulars	30 June 2021	31 March 2021	31 March 2020	31 March 2019
<b>Current</b>				
Trade Receivables				
(a) Unsecured, considered good	1,671.42	2,203.95	1,828.06	2,005.45
(b) Credit impaired	80.38	113.93	96.58	76.87
	1,751.80	2,317.88	1,924.64	2,082.32
Allowance for credit losses	(80.38)	(113.93)	(96.58)	(76.87)
<b>Net Receivables</b>	<b>1,671.42</b>	<b>2,203.95</b>	<b>1,828.06</b>	<b>2,005.45</b>
Contract assets				
(a) Unsecured, considered good	26.34	4.69	24.12	97.79
	26.34	4.69	24.12	97.79
Allowance for credit losses	-	-	-	-
<b>Net Contract Assets</b>	<b>26.34</b>	<b>4.69</b>	<b>24.12</b>	<b>97.79</b>
<b>Total</b>	<b>1,697.76</b>	<b>2,208.64</b>	<b>1,852.18</b>	<b>2,103.24</b>

**Trade receivables ageing schedule:**

**(i) As at 30 June 2021**

Particulars	Outstanding for following periods from due date of payment						Total
	Not Due	Less than 6 months	6 months- 1 year	1-2 years	2-3 years	More than 3 years	
(i) Undisputed Trade receivables - considered good	851.01	626.72	121.41	52.09	5.29	6.53	1,663.05
(ii) Undisputed Trade Receivables - which have significant increase in credit risk	-	-	-	-	-	-	-
(iii) Undisputed Trade Receivables - credit impaired	7.46	10.25	6.16	27.43	3.22	25.86	80.38
(iv) Disputed Trade Receivables - considered good	-	-	-	-	-	8.37	8.37
(v) Disputed Trade Receivables - which have significant increase in credit risk	-	-	-	-	-	-	-
(vi) Disputed Trade Receivables - credit impaired	-	-	-	-	-	-	-
<b>Total</b>	<b>858.47</b>	<b>636.97</b>	<b>127.57</b>	<b>79.52</b>	<b>8.51</b>	<b>40.76</b>	<b>1,751.80</b>

**(ii) As at 31 March 2021**

Particulars	Outstanding for following periods from due date of payment						Total
	Not Due	Less than 6 months	6 months-1 year	1-2 years	2-3 years	More than 3 years	
(i) Undisputed Trade receivables - considered good	1,068.32	970.22	91.05	45.88	6.34	22.14	2,203.95
(ii) Undisputed Trade Receivables - which have significant increase in credit risk	-	-	-	-	-	-	-
(iii) Undisputed Trade Receivables - credit impaired	7.94	21.96	15.13	38.48	10.54	19.88	113.93
(iv) Disputed Trade Receivables - considered good	-	-	-	-	-	-	-
(v) Disputed Trade Receivables - which have significant increase in credit risk	-	-	-	-	-	-	-
(vi) Disputed Trade Receivables - credit impaired	-	-	-	-	-	-	-
<b>Total</b>	<b>1,076.26</b>	<b>992.18</b>	<b>106.18</b>	<b>84.36</b>	<b>16.88</b>	<b>42.02</b>	<b>2,317.88</b>

**(iii) As at 31 March 2020**

Particulars	Outstanding for following periods from due date of payment						Total
	Not Due	Less than 6 months	6 months-1 year	1-2 years	2-3 years	More than 3 years	
(i) Undisputed Trade receivables - considered good	696.94	913.55	101.08	83.66	17.39	15.44	<b>1,828.06</b>
(ii) Undisputed Trade Receivables - which have significant increase in credit risk	-	-	-	-	-	-	-
(iii) Undisputed Trade Receivables - credit impaired	7.77	16.66	8.04	20.53	24.29	19.29	<b>96.58</b>
(iv) Disputed Trade Receivables - considered good	-	-	-	-	-	-	-
(v) Disputed Trade Receivables - which have significant increase in credit risk	-	-	-	-	-	-	-
(vi) Disputed Trade Receivables - credit impaired	-	-	-	-	-	-	-
<b>Total</b>	<b>704.71</b>	<b>930.21</b>	<b>109.12</b>	<b>104.19</b>	<b>41.68</b>	<b>34.73</b>	<b>1,924.64</b>

**(iv) As at 31 March 2019**

Particulars	Outstanding for following periods from due date of payment						Total
	Not Due	Less than 6 months	6 months-1 year	1-2 years	2-3 years	More than 3 years	
(i) Undisputed Trade receivables - considered good	1,085.52	625.56	151.85	116.44	13.82	12.26	<b>2,005.45</b>
(ii) Undisputed Trade Receivables - which have significant increase in credit risk	-	-	-	-	-	-	-
(iii) Undisputed Trade Receivables - credit impaired	21.08	17.48	5.21	12.64	12.43	8.03	<b>76.87</b>
(iv) Disputed Trade Receivables - considered good	-	-	-	-	-	-	-
(v) Disputed Trade Receivables - which have significant increase in credit risk	-	-	-	-	-	-	-
(vi) Disputed Trade Receivables - credit impaired	-	-	-	-	-	-	-
<b>Total</b>	<b>1,106.60</b>	<b>643.04</b>	<b>157.06</b>	<b>129.08</b>	<b>26.25</b>	<b>20.29</b>	<b>2,082.32</b>

**Note:**

(i) There are no outstanding receivable due from directors or other officers of the company.

(ii) Trade Receivables and Contract Assets have been pledged to secure borrowings of the group, wherever applicable (Refer Note 20 and Note 23).

(iii) Refer note 40(A) for credit risk.

(iv) Contract assets as at each reporting dates are undisputed and falling within the "Not Due" bracket. Unbilled dues amounting to INR 26.34 Mn (31 March 2021: INR 1.52 Mn, 31 March 2020: INR 24.12 Mn and 31 March 2019: INR 4.09 Mn) are included under Contract Assets.

**Note: 14 Cash and cash equivalents**

Particulars	30 June 2021	31 March 2021	31 March 2020	31 March 2019
Cash on hand	1.10	1.29	0.98	0.94
Balances with banks				
In current accounts	472.90	343.32	225.97	191.63
In deposit account (less than 3 months maturity)	171.77	134.09	141.68	0.07
<b>Total</b>	<b>645.77</b>	<b>478.70</b>	<b>368.63</b>	<b>192.64</b>

**Note: 15 Other bank balances**

Particulars	30 June 2021	31 March 2021	31 March 2020	31 March 2019
Earmarked accounts				
-In Unpaid Dividend accounts	-	0.10	0.10	0.13
In deposit account*	9.80	5.30	0.38	4.25
<b>Total</b>	<b>9.80</b>	<b>5.40</b>	<b>0.48</b>	<b>4.38</b>

\*INR 1.64 Mn (31 March 2021: INR 5.21 Mn ; 31 March 2020: INR 0.38 Mn and 31 March 2019: INR 4.09 Mn) Lodged as security against bank guarantee.

**Note: 16 Other financial assets - current**

Particulars	30 June 2021	31 March 2021	31 March 2020	31 March 2019
<b>Unsecured, considered good</b>				
Security deposits	9.15	9.12	0.64	3.93
Interest receivables	1.36	1.19	-	1.27
Derivative assets	25.39	30.76	24.92	37.56
Other receivables*	16.17	1.20	5.42	1.94
<b>Total</b>	<b>52.07</b>	<b>42.27</b>	<b>30.98</b>	<b>44.70</b>

\* Includes an amount of INR 15.34 Mn as at June 30, 2021 recoverable from selling shareholders which was incurred in relation to proposed initial public offer.

**Note: 17 Current tax assets (net)**

Particulars	30 June 2021	31 March 2021	31 March 2020	31 March 2019
Advance Income Tax (Net of Provision for Income Tax)	7.28	15.49	30.54	13.14
<b>Total</b>	<b>7.28</b>	<b>15.49</b>	<b>30.54</b>	<b>13.14</b>

**Note: 18 Other current assets**

Particulars	30 June 2021	31 March 2021	31 March 2020	31 March 2019
<b>Unsecured, considered good (unless otherwise stated)</b>				
Accruals under duty drawback and other export incentives	112.79	120.51	160.75	137.07
Balances with government authorities	147.24	116.86	134.69	148.06
Advance to suppliers				
Considered good	47.67	46.63	67.83	91.26
Considered doubtful	2.27	1.26	-	2.90
Less: Provision for doubtful advances	(2.27)	(1.26)	-	(2.90)
Prepaid expenses	37.11	38.32	39.55	35.80
Employee advances	6.75	6.10	12.75	13.27
Other receivables	0.46	-	1.25	2.51
<b>Total</b>	<b>352.02</b>	<b>328.42</b>	<b>416.82</b>	<b>427.97</b>

**Note: 19A Equity share capital**

**(a) Authorised share capital**

Particulars	Number of shares	Amount
As at 1 April 2018	70,000,000	700.00
Changes during the year	-	-
<b>As at 31 March 2019</b>	<b>70,000,000</b>	<b>700.00</b>
Changes during the year	-	-
<b>As at 31 March 2020</b>	<b>70,000,000</b>	<b>700.00</b>
Changes during the year	-	-
<b>As at 31 March 2021</b>	<b>70,000,000</b>	<b>700.00</b>
Changes during the period	-	-
<b>As at 30 June 2021</b>	<b>70,000,000</b>	<b>700.00</b>

**(b) Issued, Subscribed and fully Paid -up Shares**

Particulars	Number of shares	Amount
As at 1 April 2018	57,600,868	576.01
Changes during the year	-	-
<b>As at 31 March 2019</b>	<b>57,600,868</b>	<b>576.01</b>
Changes during the year	-	-
<b>As at 31 March 2020</b>	<b>57,600,868</b>	<b>576.01</b>
Changes during the year	-	-
<b>As at 31 March 2021</b>	<b>57,600,868</b>	<b>576.01</b>
Changes during the period	-	-
<b>As at 30 June 2021</b>	<b>57,600,868</b>	<b>576.01</b>

**(c) Equity shares held by the parent company of the company**

Particulars	As at 30 June 2021		As at 31 March 2021		As at 31 March 2020		As at 31 March 2019	
	No.	% holding	No.	% holding	No.	% holding	No.	% holding
<b>Equity shares</b>								
Nihal Fiscal Services Private Limited, the ultimate holding company	36,553,153	63.46%	36,553,153	63.46%	36,553,153	63.46%	36,553,153	63.46%

**(d) Details of the shareholders holding more than 5% of equity shares of the Company**

Name of the shareholder	As at 30 June 2021		As at 31 March 2021		As at 31 March 2020		As at 31 March 2019	
	No.	% holding	No.	% holding	No.	% holding	No.	% holding
<b>Equity shares</b>								
Nihal Fiscal Services Private Limited, the ultimate holding company	36,553,153	63.46%	36,553,153	63.46%	36,553,153	63.46%	36,553,153	63.46%
Mr Madan Mohan Mohanka	8,663,159	15.04%	10,645,453	18.48%	10,645,453	18.48%	8,461,427	14.69%
Mr Manish Mohanka	7,941,856	13.79%	7,941,856	13.79%	7,941,856	13.79%	7,941,856	13.79%



**(e) Rights, preferences and restrictions attached to equity shares**

The group has one class of equity shares having par value of INR 10/-. Each equity shareholder is entitled to vote in the same proportion as the equity capital paid (whether fully paid or partly paid) held by the shareholder bears to the total paid up equity capital of the group. Each equity shareholder is entitled to dividend in proportion of the amount paid up as and when the group declares and pays dividend after obtaining shareholders' approval. Dividends are paid in Indian Rupees. In the event of liquidation, the Equity Shareholders are eligible to receive the remaining assets of the group after distribution of all preferential amounts, in proportion to their shareholding.

Wagner Limited ("the Investor") holds 76,893 equity shares in the Holding Company. The Holding Company had issued Bonus shares in October 2013 in the ratio of 12:1 on both its Equity shares and CCPP. Post this issue the number of equity shares held by Wagner Limited in the Holding Company stands at 999,609 shares. Also refer Note 49.

**Put Option**

As per the shareholders agreement dated 29 April 2011 and subsequent amendments thereof, if for any reason, whatsoever, the Holding Company fails to conduct the IPO before 30 September 2021 (subsequently extended to 31 December 2021 or such other date as may be mutually agreed between the parties prior to 31 December 2021 ("Long Stop Date") vide amendment agreement dated 7 August 2021 ("Put Option Trigger Date"), the Investor shall either require the Promoters to purchase any or all of the Investor Shares held by the Investor as on the date of exercise of the put option ("Put Shares"), and the Promoters shall be obliged to purchase the Put Shares ("Put Option") or cause the Holding Company to buy back the Put Shares ("Buy-Back Option") at the Fair Market Value price per Put Share.

**(f) Shares reserved for issue under options**

Pursuant to approved employee stock option scheme 2011, the Group has granted 498,628 nos of employees stock options of which none of the options have been exercised. Also refer Note 47.

**(g) Shares held by the promoters**

**(i) As at 30 June 2021**

Serial Number	Promoter name	No. of shares	%of total shares	% change during the period
	<b>Equity shares</b>			
1	Mr Madan Mohan Mohanka	8,663,159	15.04%	-3.44%
2	Mr Mehul Mohanka	2,003,315	3.48%	3.48%
3	Mr Manish Mohanka	7,941,856	13.79%	NIL
4	Nihal Fiscal Services Private Limited	36,553,153	63.46%	NIL
<b>Total</b>		<b>55,161,483</b>	<b>95.77%</b>	

**(ii) As at 31 March 2021**

Serial Number	Promoter name*	No. of shares	%of total shares	% change during the year
	<b>Equity shares</b>			
1	Mr Madan Mohan Mohanka	10,645,453	18.48%	NIL
2	Mr Manish Mohanka	7,941,856	13.79%	NIL
3	Nihal Fiscal Services Private Limited	36,553,153	63.46%	NIL
<b>Total</b>		<b>55,140,462</b>	<b>95.73%</b>	

(iii) As at 31 March 2020

Serial Number	Promoter name*	No. of shares	%of total shares	% change during the year
	<b>Equity shares</b>			
1	Mr Madan Mohan Mohanka	10,645,453	18.48%	3.79%
2	Mr Manish Mohanka	7,941,856	13.79%	NIL
3	Madan Mohan Mohanka (HUF)	-	0.00%	-3.79%
4	Mehul Mohanka (HUF)	14,521	0.03%	NIL
5	Marudhar Food & Credit Limited	1,300,000	2.26%	NIL
6	Nihal Fiscal Services Private Limited	36,553,153	63.46%	NIL
<b>Total</b>		<b>56,454,983</b>	<b>98.02%</b>	

(iv) As at 31 March 2019

Serial Number	Promoter name*	No. of shares	%of total shares	% change during the year
	<b>Equity shares</b>			
1	Mr Madan Mohan Mohanka	8,461,427	14.69%	0.01%
2	Mr Manish Mohanka	7,941,856	13.79%	NIL
3	Madan Mohan Mohanka (HUF)	2,184,026	3.79%	NIL
4	Mehul Mohanka (HUF)	14,521	0.03%	NIL
5	Marudhar Food & Credit Limited	1,300,000	2.26%	NIL
6	Nihal Fiscal Services Private Limited	36,553,153	63.46%	NIL
<b>Total</b>		<b>56,454,983</b>	<b>98.02%</b>	

\*considered as per the annual return filed by the company for the respective years

**Note: 19B Preference share capital**

**(a) Authorised share capital**

**Compulsorily Convertible Participatory Preference shares**

Particulars	Number of shares	Amount
As at 1 April 2018	10,000,000	100.00
Changes during the year	-	-
<b>As at 31 March 2019</b>	<b>10,000,000</b>	<b>100.00</b>
Changes during the year	-	-
<b>As at 31 March 2020</b>	<b>10,000,000</b>	<b>100.00</b>
Changes during the year	-	-
<b>As at 31 March 2021</b>	<b>10,000,000</b>	<b>100.00</b>
Changes during the period	-	-
<b>As at 30 June 2021</b>	<b>10,000,000</b>	<b>100.00</b>

**Redeemable Preference shares**

Particulars	Number of shares	Amount
As at 1 April 2018	25,000,000	250.00
Changes during the year	-	-
<b>As at 31 March 2019</b>	<b>25,000,000</b>	<b>250.00</b>
Changes during the year	-	-
<b>As at 31 March 2020</b>	<b>25,000,000</b>	<b>250.00</b>
Changes during the year	-	-
<b>As at 31 March 2021</b>	<b>25,000,000</b>	<b>250.00</b>
Changes during the period	-	-
<b>As at 30 June 2021</b>	<b>25,000,000</b>	<b>250.00</b>

**(b) Issued, Subscribed and fully Paid -up Shares**

**Compulsorily Convertible Participatory Preference shares**

Particulars	Number of shares	Amount
As at 1 April 2018	8,692,281	86.92
Changes during the year	-	-
<b>As at 31 March 2019</b>	<b>8,692,281</b>	<b>86.92</b>
Changes during the year	-	-
<b>As at 31 March 2020</b>	<b>8,692,281</b>	<b>86.92</b>
Changes during the year	-	-
<b>As at 31 March 2021</b>	<b>8,692,281</b>	<b>86.92</b>
Changes during the period	-	-
<b>As at 30 June 2021</b>	<b>8,692,281</b>	<b>86.92</b>

**(c) Details of preference shareholders holding more than 5% of preference shares of the company**

Name of the shareholder	As at 30 June 2021		As at 31 March 2021		As at 31 March 2020		As at 31 March 2019	
	No.	% holding	No.	% holding	No.	% holding	No.	% holding
<b>Compulsorily Convertible Participatory Preference shares</b>								
Wagner Limited	8,692,281	100%	8,692,281	100%	8,692,281	100%	8,692,281	100%

**(d) Rights, preferences and restrictions attached to preference shares**

The Group has issued compulsorily convertible participatory preference shares (CCPP) at face value of INR 10/- each having right to a preferential dividend of a fixed amount aggregating to INR 500/- per annum.

**Conversion Option as at 30 June 2021:**

The date of conversion is the earliest of

- (a) Immediately prior to transfer of CCPP by the Investor, (other than to its affiliates) in accordance with shareholders agreement dated 29 April 2011 and subsequent amendments thereof.
- (b) The Company filing its red herring prospectus for an initial public offering
- (c) 30 September 2021 (subsequently extended to 31 December 2021 or such other date as may be mutually agreed between the parties prior to 31 December 2021 ("Long Stop Date") vide amendment agreement dated 7 August 2021)

**Conversion Option as at 31 March 2021:**

The date of conversion is the earliest of

- (a) Immediately prior to transfer of CCPP by the Investor, (other than to its affiliates) in accordance with shareholders agreement dated 29 April 2011 and subsequent amendments thereof.
- (b) The Company filing its red herring prospectus for an initial public offering
- (c) 30 September 2021

**Conversion Option as at 31 March 2020:**

The date of conversion is the earliest of

- (a) Immediately prior to transfer of CCPP by the Investor, (other than to its affiliates) in accordance with shareholders agreement dated 29 April 2011 and subsequent amendments thereof.
- (b) The Company filing its red herring prospectus for an initial public offering
- (c) 1 April 2021

**Conversion Option as at 31 March 2019:**

The date of conversion is the earliest of

- (a) Immediately prior to transfer of CCPP by the Investor, (other than to its affiliates) in accordance with shareholders agreement dated 29 April 2011 and subsequent amendments thereof.
- (b) The Company filing its red herring prospectus for an initial public offering
- (c) 1 April 2020

**(e) Terms of conversion for compulsorily convertible participatory preference shares:**

The Holding Company had issued 668,637 compulsorily convertible participatory preference shares (CCPP) to Wagner Limited on the terms and conditions as detailed in the Share Subscription and Shareholder Agreement (the Agreement) dated 29 April 2011 and subsequent amendments thereof, entered into between the Holding Company and Wagner Limited. The Agreement inter alia provided for the mode and manner of conversion of 668,637 CCPP into 668,637 Equity shares. The Holding Company issued Bonus shares in October 2013 in the ratio of 12:1 on both its Equity shares and CCPP. Post this issue the number of CCPP held by Wagner Limited in the Holding Company stands at 8,692,281 shares. Also refer Note 49.

In a liquidity event (a) the CCPP will rank senior to the Equity Shares and any other Equity Securities issued by the Group; and (b) the Shares shall have liquidation preference equal to the investment amount.

Optional Conversion: The Investor shall have the right to convert the CCPP into Equity Shares (at the Investor's option); at any time and from time to time: (a) after 2 (two) years from the Closing Date; or (b) upon the occurrence of a Liquidity Event. "Closing date" as per "Share Subscription and Share Purchase Agreement" dated is the such dates as the party may mutually agree to in writing.

**Put Option**

As per the shareholders agreement dated 29 April 2011 and subsequent amendments thereof, if for any reason, whatsoever, the Holding Company fails to conduct the IPO before 30 September 2021 (subsequently extended to 31 December 2021 or such other date as may be mutually agreed between the parties prior to 31 December 2021 ("Long Stop Date") vide amendment agreement dated 7 August 2021 ("Put Option Trigger Date"), the Investor shall either require the Promoters to purchase any or all of the Investor Shares held by the Investor as on the date of exercise of the put option ("Put Shares"), and the Promoters shall be obliged to purchase the Put Shares ("Put Option") or cause the Holding Company to buy back the Put Shares ("Buy-Back Option") at the Fair Market Value price per Put Share.

**Note: 19C Other equity**

Particulars	Refer below	30 June 2021	31 March 2021	31 March 2020	31 March 2019
Securities premium	(i)	902.10	902.10	902.10	902.10
General reserve	(ii)	337.98	337.98	337.98	337.98
Retained earnings	(iii)	4,327.79	4,210.82	2,839.84	2,180.69
Foreign Currency Translation Reserve	(iv)	80.24	22.91	(118.44)	(73.13)
Share options outstanding account	(v)	0.48	0.48	0.48	0.48
<b>Total</b>		<b>5,648.59</b>	<b>5,474.29</b>	<b>3,961.96</b>	<b>3,348.12</b>

Particulars	30 June 2021	31 March 2021	31 March 2020	31 March 2019
(i) Securities premium				
Balance at the beginning and end of the period/ year	902.10	902.10	902.10	902.10
(ii) General reserve				
Balance at the beginning and end of the period/ year	337.98	337.98	337.98	337.98
(iii) Retained earnings				
Balance at the beginning of the period/ year	4,210.82	2,839.84	2,180.69	1,855.25
Ind AS 116 transition adjustment (refer Annexure VI)	-	-	9.66	-
Balance as on 1 April as per Audited Consolidated Financial Statements	4,210.82	2,839.84	2,190.35	1,855.25
Restated profit for the period/ year	118.82	1,364.05	655.04	326.28
<i>Items of other comprehensive income recognised directly in retained earnings</i>				
- Remeasurements of post-employment benefit obligation, net of tax	(1.85)	2.36	(4.16)	(3.92)
Transfers within equity	-	(3.08)	-	-
Other Adjustments	-	7.65	-	-
Adjustment arising on disposal of subsidiaries	-	-	-	3.54
Appropriations				
Dividend on preference shares	-	(0.00 <sup>^</sup> )	(0.00 <sup>^</sup> )	(0.00 <sup>^</sup> )
Tax on dividend on preference shares	-	-	-	(0.00 <sup>^</sup> )
Tax on dividend from joint venture	-	-	(1.39)	(0.46)
Balance at the end of the period/ year	<b>4,327.79</b>	<b>4,210.82</b>	<b>2,839.84</b>	<b>2,180.69</b>
(iv) Foreign Currency Translation Reserve				
Balance at the beginning of the period/ year	22.91	(118.44)	(73.13)	11.36
Ind AS 116 transition adjustment (refer Annexure VI)	-	-	(0.20)	-
Balance as on 1 April as per Audited Consolidated Financial Statements	22.91	(118.44)	(73.33)	11.36
Add: Transfers within equity	-	3.08	-	-
Add: Adjustment for translation of Non Integral Foreign Operation	57.33	138.27	(45.11)	(84.49)
Balance at the end of the period/ year	<b>80.24</b>	<b>22.91</b>	<b>(118.44)</b>	<b>(73.13)</b>
(v) Share options outstanding account				
Balance at the beginning and end of the period/ year	0.48	0.48	0.48	0.48
<b>Total</b>	<b>5,648.59</b>	<b>5,474.29</b>	<b>3,961.96</b>	<b>3,348.12</b>

<sup>^</sup>Amount is below the rounding off norm adopted by the Group

**Nature and purpose of other reserves**

*(i) Securities premium reserve*

Securities premium is used to record the premium received on issue of shares. The reserve is utilised in accordance with the provisions of the Companies Act, 2013.

*(ii) General reserve*

Under the erstwhile Companies Act 1956, a general reserve was created through an annual transfer of net profit at a specified percentage in accordance with applicable regulations. Consequent to the introduction of the Companies Act 2013, the requirement to mandatory transfer a specified percentage of net profit to general reserve has been withdrawn.

*(iii) Retained earnings*

Retained Earnings are the profits that the Company has earned till date, less any transfer to general reserve, dividends or other distributions paid to shareholders.

*(iv) Foreign Currency Translation Reserve*

Exchange differences arising on translation of assets, liabilities, income and expenses of the Group's foreign subsidiaries are recognised in restated other comprehensive income and accumulated separately in foreign currency translation reserve. The amounts recognised are transferred to the Restated Consolidated Statement of Profit and Loss on disposal of the related foreign subsidiaries.

*(v) Share options outstanding account*

The share options outstanding account is used to recognise the grant date fair value of options issued to employees under the Company's Employee stock option plan. Refer note 47.

**Note: 20 Borrowings - Non current**

Particulars	30 June 2021	31 March 2021	31 March 2020	31 March 2019
<b>Secured</b>				
Term Loans from banks (Refer (a) and (b) below)	981.97	1,008.01	1,051.74	828.67
Less: Current Maturities of Long Term Debt (Refer Note 23)	(200.63)	(187.89)	(113.50)	(239.87)
<b>Total (A)</b>	<b>781.34</b>	<b>820.12</b>	<b>938.24</b>	<b>588.80</b>
<b>Secured</b>				
Vehicle loans from banks (Refer (c) below)	10.08	10.86	17.23	13.23
Less: Current Maturities of Long Term Debt (Refer Note 23)	(3.30)	(3.34)	(4.40)	(4.70)
<b>Total (B)</b>	<b>6.78</b>	<b>7.52</b>	<b>12.83</b>	<b>8.53</b>
<b>Total Secured Borrowings (C = A+B)</b>	<b>788.12</b>	<b>827.64</b>	<b>951.07</b>	<b>597.33</b>
<b>Unsecured</b>				
Term Loans from banks (Refer (d) below)	53.16	58.43	-	-
Less: Current Maturities of Long Term Debt (Refer Note 23)	(24.43)	(23.97)	-	-
<b>Total Unsecured Borrowings (D)</b>	<b>28.73</b>	<b>34.46</b>	<b>-</b>	<b>-</b>
<b>Total (C+D)</b>	<b>816.85</b>	<b>862.10</b>	<b>951.07</b>	<b>597.33</b>

**(a) Details of secured term loan facilities from banks are as follows:**

Terms of Repayment	30 June 2021*	31 March 2021*	31 March 2020*	31 March 2019*	Currency	Maturity Date	Interest Rate
Repayable in 20 unequal quarterly installments starting from 28 June 2018 in the following manner:(a) first 4 installments of 2.50% each (b) next 6 installments of 4.00% each (c) next 2 installments of 6.00% each (d) next 4 installments of 8.00% each (e) next 2 installments of 5.00% each (f) next 2 installments of 6.00% each	85.48	98.70	139.98	155.60	USD	28-Mar-23	3 month USD LIBOR plus 300 basis points
Repayable in 28 unequal quarterly installments starting from 28 June 2018 in the following manner:(a) first 4 installments of 0.50% each (b) next 4 installments of 1.00% each (c) next 6 installments of 2.00% each (d) next 4 installments of 4.00% each (e) next 6 installments of 6.00% each (f) next 4 installments of 7.50% each	156.09	157.19	177.81	169.43	USD	28-Mar-25	3 month USD LIBOR plus 325 basis points
Repayable in 20 unequal quarterly installments starting from 22 October 2019 in the following manner:(a) first 4 installments of 2.50% each (b) next 6 installments of 4.00% each (c) next 2 installments of 6.00% each (d) next 4 installments of 8.00% each (e) next 2 installments of 5.00% each (f) next 2 installments of 6.00% each	289.89	299.75	359.41	-	USD	22-Jul-24	3 month USD LIBOR plus 290 basis points
Repayable in 28 unequal quarterly installments starting from 22 October 2019 in the following manner:(a) first 4 installments of 0.50% each (b) next 4 installments of 1.00% each (c) next 6 installments of 2.00% each (d) next 4 installments of 4.00% each (e) next 6 installments of 6.00% each (f) next 4 installments of 7.50% each	353.07	350.92	374.54	-	USD	22-Jul-26	3 month USD LIBOR plus 315 basis points
Repayable in 16 equal quarterly installments starting from 19 February 2021	97.44	101.45	-	-	USD	19-Nov-24	3 month USD LIBOR plus 240 basis points
Repayable in 10 equal quarterly installments starting from 28 December 2017	-	-	-	24.76	INR	Repaid during the financial year 2019-2020	10.25% p.a.
Repayable in 14 equal quarterly installments starting from 17 July 2018	-	-	-	462.73	USD	Repaid during the financial year 2019-2020	3 month USD LIBOR plus 288 basis points
Repayable in 33 equal monthly instalments starting from 16 January 2017	-	-	-	16.15	ZAR	Repaid during the financial year 2019-2020	Prime Rate + 1.50% p.a.

\* based on closing rate

(b) Terms loans of INR 884.53 Mn (31 March 2021: INR 906.56 Mn ; 31 March 2020: INR 1,051.74 Mn and 31 March 2019: INR 365.94 Mn) are secured by first charge on pari-passu basis with the existing lender wherever applicable on fixed assets of the company (both moveable and immovable) and second charge on the current assets to be shared on pari-passu basis with the other working capital and term lenders of the Borrower. Exclusive charge of term loans over certain mutual funds given on lien as Minimum Reserve Amount. Also refer note 6 and 12.

Term Loan of INR 97.44 Mn (31 March 2021: INR 101.45 Mn ; 31 March 2020: INR NIL and 31 March 2019: INR NIL) is secured by Stand-By Letter of Credit given by the Holding Company.

Term Loan of INR NIL (31 March 2021: INR NIL ; 31 March 2020: INR NIL and 31 March 2019: INR 462.73) is secured by Corporate Guarantee given by the Holding Company.

(c) Vehicle loans of INR 8.07 Mn (31 March 2021: INR 8.74 Mn ; 31 March 2020: INR 12.15 Mn and 31 March 2019: INR 10.06 Mn) is secured by hypothecation of vehicle purchased and are repayable in thirty six to sixty monthly equated installments commencing from the subsequent month in which the loan is taken carrying fixed interest ranging from 8.50% to 12.00% per annum.

Vehicle loan of INR NIL (31 March 2021: INR NIL ; 31 March 2020: INR 2.50 Mn and 31 March 2019: INR NIL) is secured by hypothecation of vehicle purchased and is interest free and repayable in bi-weekly installments of INR 0.02 Mn each during the period upto 24 May 2024.

Vehicle loan of INR 2.01 Mn (31 March 2021: INR 2.12 Mn ; 31 March 2020: INR 2.58 Mn and 31 March 2019: INR 3.17 Mn) is secured by hypothecation of vehicle purchased and is interest free and repayable in bi-weekly installments of INR 0.03 Mn each during the period upto 2 April 2024.

**(d) Details of unsecured term loan facilities from banks are as follows:**

Terms of Repayment	30 June 2021*	31 March 2021*	31 March 2020*	31 March 2019*	Currency	Maturity Date	Interest Rate
Repayable fully upto 31 December 2022 and is eligible for forgiveness of CAD 20,000, if the balance amount of CAD 40,000 is repaid by the said date	3.42	3.29	-	-	CAD	31-Dec-22	Interest Free
Repayable in 30 equated monthly installments starting from 15 January 2021	49.74	55.14	-	-	CLP	15-Jun-23	3.84% p.a.

\* based on closing rate

**Note: 21 Other financial liabilities - non current**

Particulars	30 June 2021	31 March 2021	31 March 2020	31 March 2019
Derivative liabilities	82.66	89.23	133.07	33.74
<b>Total</b>	<b>82.66</b>	<b>89.23</b>	<b>133.07</b>	<b>33.74</b>

**Note: 22 Deferred tax liabilities (net)**

Particulars	30 June 2021	31 March 2021	31 March 2020	31 March 2019
<b>The balance comprises temporary differences attributable to:</b>				
<b>Deferred tax liabilities</b>				
Property, plant and equipment and Intangible assets	72.87	74.29	35.52	92.08
Undistributed earnings of Joint Venture	39.83	38.20	47.42	24.74
Fair valuation of investment	30.87	26.81	-	8.66
Right-of-Use assets	8.23	10.24	1.85	27.20
Other temporary difference	2.65	1.19	1.02	1.65
<b>Total</b>	<b>154.45</b>	<b>150.82</b>	<b>85.81</b>	<b>154.33</b>
<b>Deferred tax assets</b>				
Allowance for doubtful debts and advances	12.66	12.10	0.71	15.26
Amounts allowable for tax purpose on payment basis	41.41	36.61	0.93	38.99
Accumulated losses *	-	-	8.90	17.48
Lease liabilities	10.08	12.17	1.96	28.21
Other temporary difference	15.49	2.33	5.89	2.97
<b>Total</b>	<b>79.64</b>	<b>63.21</b>	<b>18.39</b>	<b>102.91</b>
<b>Deferred tax liabilities (net)</b>	<b>74.81</b>	<b>87.61</b>	<b>67.42</b>	<b>51.42</b>

Refer note 37 for tax expenses

\* absorption expected based on future taxable income

**Note: 23 Borrowings - current**

Particulars	30 June 2021	31 March 2021	31 March 2020	31 March 2019
<b>Secured</b>				
Rupee loan from banks (Refer (a) below)	529.26	626.00	827.07	948.55
Foreign currency loans from banks (Refer (b) below)	267.91	174.72	543.30	336.45
Current maturities of long-term debt				
Term loan from banks	225.06	211.86	113.50	239.87
Vehicle loan from banks	3.30	3.34	4.40	4.70
<b>Total</b>	<b>1,025.53</b>	<b>1,015.92</b>	<b>1,488.27</b>	<b>1,529.57</b>

**Nature of Security:**

(a) All the above facilities are secured by first charge over entire current assets (both present and future) of the Group on pari-passu basis with other banks and collaterally secured by mortgage/ hypothecation charge on the immovable and moveable fixed assets owned by the Group on pari-passu second charge basis with other Banks. Interest rate ranges from 4.40% to 5.97% (31 March 2021: 4.50% to 13.50% ; 31 March 2020: 8.50% to 10.75% and 31 March 2019: 8.50% to 10.75%).

(b) Foreign currency loan from bank of INR 141.06 Mn (31 March 2021: INR 137.01 Mn ; 31 March 2020: INR 143.14 Mn and 31 March 2019: INR 131.28 Mn) is secured by Stand-By Letter of Credit given by the Holding Company.

Foreign currency loan from bank of INR 126.85 Mn (31 March 2021: INR 37.71 Mn ; 31 March 2020: INR 400.16 Mn and 31 March 2019: INR 205.17 Mn) is secured first charge over entire current assets (both present and future) of the Group on pari-passu basis with other banks and collaterally secured by mortgage/ hypothecation charge on the immovable and moveable fixed assets owned by the Group on pari-passu second charge basis with other Banks. Interest rate ranges from 0.30% to 5.04% (31 March 2021: 2.34% to 8.80% ; 31 March 2020: 0.50% to 11.75% and 31 March 2019: 2.75% to 10.25%).



**Note: 24 Trade payables**

Particulars	30 June 2021	31 March 2021	31 March 2020	31 March 2019
(a) Total outstanding dues of micro enterprises and small enterprises	38.26	42.20	32.00	33.58
(b) Total outstanding dues of creditors other than micro enterprises and small enterprises				
(i) Acceptances	327.85	372.18	21.62	187.15
(ii) Others	808.33	572.72	599.34	586.10
<b>Total</b>	<b>1,174.44</b>	<b>987.10</b>	<b>652.96</b>	<b>806.83</b>

**Trade payables ageing schedule:**

**(i) As at 30 June 2021**

Particulars	Outstanding for following periods from due date of payment						Total
	Unbilled	Not Due	Less than 1 year	1-2 years	2-3 years	More than 3 years	
(a) Undisputed total outstanding dues of micro and small enterprises	-	18.22	6.10	3.02	3.21	7.71	<b>38.26</b>
(b) Undisputed total outstanding dues of creditors other than micro and small enterprises	186.52	640.13	304.95	0.88	0.68	3.02	<b>1,136.18</b>
(c) Disputed dues of micro and small enterprises	-	-	-	-	-	-	-
(d) Disputed total outstanding dues of creditors other than micro and small enterprises	-	-	-	-	-	-	-
<b>Total</b>	<b>186.52</b>	<b>658.35</b>	<b>311.05</b>	<b>3.90</b>	<b>3.89</b>	<b>10.73</b>	<b>1,174.44</b>

**(ii) As at 31 March 2021**

Particulars	Outstanding for following periods from due date of payment						Total
	Unbilled	Not Due	Less than 1 year	1-2 years	2-3 years	More than 3 years	
(a) Undisputed total outstanding dues of micro and small enterprises	-	27.33	3.95	-	3.51	7.41	<b>42.20</b>
(b) Undisputed total outstanding dues of creditors other than micro and small enterprises	135.16	499.54	299.80	6.51	0.81	3.08	<b>944.90</b>
(c) Disputed dues of micro and small enterprises	-	-	-	-	-	-	-
(d) Disputed total outstanding dues of creditors other than micro and small enterprises	-	-	-	-	-	-	-
<b>Total</b>	<b>135.16</b>	<b>526.87</b>	<b>303.75</b>	<b>6.51</b>	<b>4.32</b>	<b>10.49</b>	<b>987.10</b>

**(iii) As at 31 March 2020**

Particulars	Outstanding for following periods from due date of payment						Total
	Unbilled	Not Due	Less than 1 year	1-2 years	2-3 years	More than 3 years	
(a) Undisputed total outstanding dues of micro and small enterprises	-	15.52	5.49	3.58	2.69	4.72	<b>32.00</b>
(b) Undisputed total outstanding dues of creditors other than micro and small enterprises	115.26	193.73	300.12	4.68	4.59	2.58	<b>620.96</b>
(c) Disputed dues of micro and small enterprises	-	-	-	-	-	-	-
(d) Disputed total outstanding dues of creditors other than micro and small enterprises	-	-	-	-	-	-	-
<b>Total</b>	<b>115.26</b>	<b>209.25</b>	<b>305.61</b>	<b>8.26</b>	<b>7.28</b>	<b>7.30</b>	<b>652.96</b>

**(iv) As at 31 March 2019**

Particulars	Outstanding for following periods from due date of payment						Total
	Unbilled	Not Due	Less than 1 year	1-2 years	2-3 years	More than 3 years	
(a) Undisputed total outstanding dues of micro and small enterprises	-	13.85	10.28	4.40	2.77	2.28	<b>33.58</b>
(b) Undisputed total outstanding dues of creditors other than micro and small enterprises	120.42	309.45	334.54	5.04	0.88	2.92	<b>773.25</b>
(c) Disputed dues of micro and small enterprises	-	-	-	-	-	-	-
(d) Disputed total outstanding dues of creditors other than micro and small enterprises	-	-	-	-	-	-	-
<b>Total</b>	<b>120.42</b>	<b>323.30</b>	<b>344.82</b>	<b>9.44</b>	<b>3.65</b>	<b>5.20</b>	<b>806.83</b>

**Note: 25 Other financial liabilities - current**

Particulars	30 June 2021	31 March 2021	31 March 2020	31 March 2019
Interest accrued but not due on borrowings	6.48	7.18	10.17	9.61
Unpaid dividend	-	0.10	0.10	0.13
Derivative liabilities	14.81	22.63	48.05	5.11
Other payables				
Capital creditors	9.26	12.58	14.88	21.25
Security deposit	1.20	1.21	1.21	1.21
Employee related liabilities	90.59	82.67	81.76	90.27
<b>Total</b>	<b>122.34</b>	<b>126.37</b>	<b>156.17</b>	<b>127.58</b>

**Note: 26 Provisions - current**

Particulars	30 June 2021	31 March 2021	31 March 2020	31 March 2019
<b>(a) Provision for employee benefits (Refer note 38)</b>				
Provision for Gratuity	28.22	24.17	19.21	34.03
Provision for compensated absences	100.22	85.42	68.96	64.78
<b>(b) Others</b>				
Provision for warranty [Refer note below]	40.57	36.25	19.81	20.16
Provision for fringe benefit tax	0.43	0.53	0.68	0.52
Proposed dividend on preference share	0.00 <sup>^</sup>	0.00 <sup>^</sup>	0.00 <sup>^</sup>	0.00 <sup>^</sup>
Tax on preference dividend	-	-	-	0.00 <sup>^</sup>
<b>Total</b>	<b>169.44</b>	<b>146.37</b>	<b>108.66</b>	<b>119.49</b>

<sup>^</sup>Amount is below the rounding off norm adopted by the Group

Particulars	For the three months period ended 30 June 2021	For the year ended 31 March 2021	For the year ended 31 March 2020	For the year ended 31 March 2019
<b>Movement in Provision for warranty:</b>				
Opening Balance	36.25	19.81	20.16	22.65
Provision created during the period/ year	4.83	23.29	8.99	9.76
Provision used during the period/ year	(0.51)	(6.85)	(9.34)	(12.25)
<b>Closing Balance</b>	<b>40.57</b>	<b>36.25</b>	<b>19.81</b>	<b>20.16</b>
-Short Term	40.57	36.25	19.81	20.16
Nature of provisions :				
The Group has given warranties on certain products and services, undertaken to repair or replace the items that failed to perform satisfactorily during the warranty period. Provision made as on 30 June 2021, 31 March 2021, 31 March 2020 and 31 March 2019 represent the amount of the expected cost of meeting such obligation of rectification/ replacement.				

**Note: 27 Current tax liabilities (net)**

Particulars	30 June 2021	31 March 2021	31 March 2020	31 March 2019
Provision for income tax (net of advances)	109.79	96.53	15.44	43.70
<b>Total</b>	<b>109.79</b>	<b>96.53</b>	<b>15.44</b>	<b>43.70</b>

**Note: 28 Other current liabilities**

Particulars	30 June 2021	31 March 2021	31 March 2020	31 March 2019
Advances received from customers	125.40	110.48	180.32	122.72
Deferment of Revenue	30.16	38.87	13.84	20.15
Grant relating to export benefits	83.95	67.81	41.70	42.06
Other payables				
Statutory dues (Contribution to PF and ESIC, GST, Withholding Taxes, Entry Tax, etc.)	97.37	99.08	98.64	88.85
<b>Total</b>	<b>336.88</b>	<b>316.24</b>	<b>334.50</b>	<b>273.78</b>

**Note: 29 Revenue from operations**

Particulars	30 June 2021	31 March 2021	31 March 2020	31 March 2019
Revenue from operations	1,732.07	8,055.22	6,848.47	6,337.57
<b>Total</b>	<b>1,732.07</b>	<b>8,055.22</b>	<b>6,848.47</b>	<b>6,337.57</b>

The group has recognised the following amounts relating to revenue in the Restated Consolidated Statement of Profit and Loss:

Particulars	30 June 2021	31 March 2021	31 March 2020	31 March 2019
(i) Sale of products	1,637.79	7,737.28	6,506.37	5,953.42
(ii) Sale of services	57.72	131.82	133.66	191.00
	<b>1,695.51</b>	<b>7,869.10</b>	<b>6,640.03</b>	<b>6,144.42</b>
(iii) Other operating revenue				
Sale of scrap	9.96	40.31	27.25	26.63
Commission income	3.11	16.34	12.79	13.18
Duty drawback and other export incentives	20.22	118.79	158.45	144.53
Service Fees	3.27	10.68	9.95	8.81
<b>Total</b>	<b>1,732.07</b>	<b>8,055.22</b>	<b>6,848.47</b>	<b>6,337.57</b>

**(i) Disaggregation of revenue from contracts with customers:**

The Group derives revenue from the transfer of goods and services in the following geographical regions:

Particulars	30 June 2021	31 March 2021	31 March 2020	31 March 2019
North America	305.72	1,107.13	907.77	619.31
South America	330.16	1,990.59	1,643.10	1,388.26
EMER (Europe, Middle East and Russia)	245.65	1,247.81	1,467.27	955.84
Africa	366.78	1,822.41	1,088.31	1,447.86
Asia Pacific (South East Asia and Australia)	211.92	793.24	778.07	1,028.28
India	235.28	907.92	755.51	704.87
<b>Total</b>	<b>1,695.51</b>	<b>7,869.10</b>	<b>6,640.03</b>	<b>6,144.42</b>

During the year ended 31 March 2021, the Group has revised the geographical regions based on which their Chief Operating Decision Maker ('CODM') views its disaggregation of revenue. As a result of this the Group has clubbed "South East Asia" region and "Australia" region into "Asia Pacific" region. Also "Other Foreign Countries" region and "Europe" region has been clubbed into "EMER" region. Accordingly, in accordance with Ind AS 115, disaggregation based on the Group presence have been identified as "North America", "South America", "EMER", "Africa", "Asia Pacific" and "India". In view of the aforesaid change, "South East Asia", "Australia", "Other Foreign Countries" and "Europe" are no longer shown separately. The comparative numbers have been restated for comparability purposes.

**(ii) The Group has recognised the following revenue-related contract assets and liabilities:**

Particulars	Notes	30 June 2021	31 March 2021	31 March 2020	31 March 2019
Contract assets	13	26.34	4.69	24.12	97.79
<b>Total contract assets</b>		<b>26.34</b>	<b>4.69</b>	<b>24.12</b>	<b>97.79</b>
Contract liabilities - Deferment of Revenue	28	30.16	38.87	13.84	20.15
Contract liabilities - Advance from customers	28	125.40	110.48	180.32	122.72
<b>Total contract liabilities</b>		<b>155.56</b>	<b>149.35</b>	<b>194.16</b>	<b>142.87</b>

**(iii) Revenue recognised in relation to contract liabilities:**

The following table shows how much of the revenue recognised in the current reporting period relates to carried-forward contract liabilities.

Particulars	30 June 2021	31 March 2021	31 March 2020	31 March 2019
Revenue recognised that was included in the contract liabilities balance at the beginning of the period:				
Sale contracts	96.80	164.47	102.45	54.77

**(iv) Unsatisfied long-term sale contracts:**

The following table shows unsatisfied performance obligations resulting from long-term sale contracts.

Particulars	30 June 2021	31 March 2021	31 March 2020	31 March 2019
Aggregate amount of the transaction price allocated to long-term sale contracts that are partially or fully unsatisfied:	3,584.53	4,258.71	5,860.95	3,039.57

Management expects that 51% of the transaction price allocated to the unsatisfied contracts as of 30 June 2021 will be recognised as revenue during the next twelve months. The remaining 49% will be recognised in the next twenty four months from the aforesaid twelve months. The amount disclosed above does not include variable consideration which is constrained.

Management expects that 53% of the transaction price allocated to the unsatisfied contracts as of 31 March 2021 will be recognised as revenue during the next reporting period. The remaining 47% will be recognised in the next 2 financial year. The amount disclosed above does not include variable consideration which is constrained.

Management expects that 33% of the transaction price allocated to the unsatisfied contracts as of 31 March 2020 will be recognised as revenue during the next reporting period. The remaining 67% will be recognised in the next 2 financial year. The amount disclosed above does not include variable consideration which is constrained.

Management expects that 41% of the transaction price allocated to the unsatisfied contracts as of 31 March 2019 will be recognised as revenue during the next reporting period. The remaining 59% will be recognised in the next 2 financial year. The amount disclosed above does not include variable consideration which is constrained.

All other sale contracts are for periods of one year or less or are billed based on time incurred. As permitted under Ind-AS 115, the transaction price allocated to these unsatisfied contracts is not disclosed.

**(v) The following table shows reconciliation of revenue recognised with contract price.**

Particulars	30 June 2021	31 March 2021	31 March 2020	31 March 2019
Contract Price	1,687.27	7,908.60	6,636.41	6,198.95
Adjustments for:				
Refund Liabilities- Claims/ Liquidating damages	(0.47)	(14.47)	(2.69)	(34.38)
Contract Liabilities- Unfulfilled obligations*	8.71	(25.03)	6.31	(20.15)
<b>Total</b>	<b>1,695.51</b>	<b>7,869.10</b>	<b>6,640.03</b>	<b>6,144.42</b>

\*These unfulfilled obligations are expected to be settled within the next 12 months.

**Note: 30 Other income**

Particulars	30 June 2021	31 March 2021	31 March 2020	31 March 2019
<b>(a) Interest income</b>				
on financial instruments at amortised cost	1.12	4.06	4.14	4.10
on income tax refund	-	0.50	0.01	0.25
<b>(b) Dividend income</b>				
from investments measured at FVTPL	-	11.81	4.45	0.87
<b>(c) Other non-operating income</b>				
Net fair value gain on investments classified at FVTPL	21.34	78.13	37.35	21.31
Net gain on sale of investments classified at FVTPL	0.81	2.50	0.25	13.49
Mark to market profit on derivative instruments (net)	8.23	61.59	-	20.86
Liabilities/ Provisions no longer required written back	0.29	12.80	53.60	19.60
Gain on sale of property, plant and equipment (Net)	0.60	-	-	-
Government grant #	8.54	42.59	-	-
Net gain on foreign currency transaction and translations	10.27	277.40	-	-
Miscellaneous receipts	10.59	20.24	7.15	12.08
<b>Total</b>	<b>61.79</b>	<b>511.62</b>	<b>106.95</b>	<b>92.56</b>

#Government grant includes certain relief/ benefit provided by the government of various countries in which the group operates. These are provided for certain operating expenses e.g. salaries and wages etc. and in terms of certain interest free borrowings and forgivable loan.

**Note: 31 Cost of materials consumed**

Particulars	30 June 2021	31 March 2021	31 March 2020	31 March 2019
Opening stock	777.95	621.66	579.06	521.96
Add: Purchases	1,128.98	3,438.65	2,890.03	2,707.39
Less: Closing stock	(1,142.61)	(777.95)	(621.66)	(579.06)
<b>Total</b>	<b>764.32</b>	<b>3,282.36</b>	<b>2,847.43</b>	<b>2,650.29</b>

**Note: 32 Changes in inventories of finished goods and work-in-progress**

Particulars	30 June 2021	31 March 2021	31 March 2020	31 March 2019
Inventories at the end of the period/ year:				
Finished Goods	581.36	469.47	406.74	358.88
Work-in-progress	205.89	230.69	197.60	152.51
	<b>787.25</b>	<b>700.16</b>	<b>604.34</b>	<b>511.39</b>
Less : Inventories at the beginning of the period/ year:				
Finished Goods	469.47	406.74	358.88	330.18
Work-in-progress	230.69	197.60	152.51	111.08
	<b>700.16</b>	<b>604.34</b>	<b>511.39</b>	<b>441.26</b>
(Increase) in finished goods and work-in-progress	(87.09)	(95.82)	(92.95)	(70.13)
Exchange Difference	8.24	51.36	(16.12)	(6.33)
<b>(Increase) in finished goods and work-in-progress</b>	<b>(78.85)</b>	<b>(44.46)</b>	<b>(109.07)</b>	<b>(76.46)</b>

**Note: 33 Employee benefits expense**

Particulars	30 June 2021	31 March 2021	31 March 2020	31 March 2019
Salaries and wages	315.95	1,089.12	1,027.32	993.36
Contribution to provident and other funds [Refer note 38]	15.34	58.29	59.21	58.68
Staff welfare expenses	18.96	79.29	66.81	61.87
<b>Total</b>	<b>350.25</b>	<b>1,226.70</b>	<b>1,153.34</b>	<b>1,113.91</b>

**Note: 34 Finance costs**

Particulars	30 June 2021	31 March 2021	31 March 2020	31 March 2019
<b>Interest expense on</b>				
Leases	6.54	26.52	25.71	29.23
Income Tax	-	4.55	-	-
Bank Borrowings and Others	20.66	102.23	161.63	189.83
Other borrowing costs	1.30	5.49	7.44	6.19
Applicable loss on foreign currency transactions and translations	7.63	33.99	19.61	10.77
<b>Total</b>	<b>36.13</b>	<b>172.78</b>	<b>214.39</b>	<b>236.02</b>

**Note: 35 Depreciation and amortisation expenses**

Particulars	30 June 2021	31 March 2021	31 March 2020	31 March 2019
Depreciation of property, plant and equipment [refer note 3(a)]	79.62	306.79	308.89	320.23
Depreciation of Right of Use of Asset [refer note 3(b)]	23.90	88.07	70.84	51.96
Amortisation of intangible assets [refer note 3(d)]	1.48	6.94	3.82	5.36
<b>Total</b>	<b>105.00</b>	<b>401.80</b>	<b>383.55</b>	<b>377.55</b>

**Note: 36 Other expenses**

Particulars	30 June 2021	31 March 2021	31 March 2020	31 March 2019
Consumption of stores and spare parts	11.61	69.93	59.76	51.99
Power and fuel	60.61	213.20	215.30	210.46
Rent	6.93	16.00	21.62	27.65
Repairs to buildings	4.12	13.57	8.07	5.95
Repairs to machinery	19.93	54.44	58.07	54.58
Repairs to others	12.60	40.12	33.17	36.67
Insurance expenses	10.68	35.78	31.22	25.00
Bank charges	3.54	13.08	13.12	13.91
Rates and taxes	(2.21)	22.83	7.64	12.71
Fabrication and other expenses	35.70	156.36	133.72	113.56
Travelling and conveyance	23.95	76.86	209.01	199.03
Commission to selling agents	7.91	26.49	24.45	26.53
Marketing fees	2.01	19.28	19.30	8.74
Packing and forwarding (net)	102.16	394.23	330.04	299.02
Product installation expenses	34.09	90.36	94.04	130.06
Postage, telephone and fax	4.74	18.09	21.50	22.50
Sales promotion expenses	2.16	12.69	23.55	22.47
Professional fees	33.45	112.09	104.48	91.62
Directors' sitting fees	0.06	0.34	0.32	0.14
Allowance for expected credit loss (including bad debts and advances written off) [refer note 40A]	6.14	57.39	48.72	38.56
Warranty Expenses	4.83	23.29	8.99	9.76
Derivatives at FVTPL				
Mark to market loss on derivative instruments (net)	-	-	87.36	-
Swap/ Option Loss on Derivative Settlement (net)	11.49	44.56	23.14	13.33
Expenditure on corporate social responsibility activities#	5.44	27.26	7.51	0.96
Net loss on foreign currency transaction and translations	-	-	157.19	117.21
Net loss on sale of property, plant and equipment including intangible assets (including loss on assets scrapped/ written off)	-	37.28	8.83	14.10
Loss on disposal of a subsidiary	-	-	-	3.63
Miscellaneous expenses*	59.40	140.30	141.32	132.22
<b>Total</b>	<b>461.34</b>	<b>1,715.82</b>	<b>1,891.44</b>	<b>1,682.36</b>

# Includes INR 5.00 Mn (31 March 2021: INR NIL ; 31 March 2020: INR 5.00 Mn and 31 March 2019: INR NIL), contributed towards West Bengal State Emergency Relief fund to combat COVID-19 pandemic.

\*The Company made contribution through electoral bonds of INR NIL (31 March 2021: INR NIL ; 31 March 2020: INR NIL and 31 March 2019: INR 5.00 Mn) which is included in Miscellaneous expenses.

**Note: 37 Income tax expense**

**(a) Movement in deferred tax liability/ (assets)**

Particulars	Property, plant & equipment and Intangible assets	Right-of-Use assets	Fair valuation of investment	Allowance for doubtful debts and advances	Amounts allowable for tax purpose on payment basis	MAT credit entitlement	Accumulated losses	Lease liabilities	Others *	Total
<b>At 1 April 2018</b>	<b>136.48</b>	-	<b>19.00</b>	<b>(20.85)</b>	<b>(55.68)</b>	<b>(12.02)</b>	<b>(41.69)</b>	-	<b>(45.64)</b>	<b>(20.40)</b>
Ind AS 116 transition adjustment	(2.04)	101.93	-	-	-	-	-	(100.41)	-	(0.52)
<b>Revised opening balance as at 1 April 2018</b>	<b>134.44</b>	<b>101.93</b>	<b>19.00</b>	<b>(20.85)</b>	<b>(55.68)</b>	<b>(12.02)</b>	<b>(41.69)</b>	<b>(100.41)</b>	<b>(45.64)</b>	<b>(20.92)</b>
Charged/ (credited):										
- to profit or loss #	(34.31)	(14.63)	(10.34)	(25.14)	8.53	12.02	24.21	10.19	11.57	(17.90)
- to other comprehensive income	-	-	-	-	-	-	-	-	-	-
<b>At 31 March 2019</b>	<b>100.13</b>	<b>87.30</b>	<b>8.66</b>	<b>(45.99)</b>	<b>(47.15)</b>	-	<b>(17.48)</b>	<b>(90.22)</b>	<b>(34.07)</b>	<b>(38.82)</b>
Ind AS 116 transition adjustment	1.58	(87.30)	-	-	-	-	-	90.22	-	4.50
Regrouping adjustments	0.41	-	-	23.93	(5.39)	-	(3.45)	-	(15.50)	-
<b>At 1 April 2019</b>	<b>102.12</b>	-	<b>8.66</b>	<b>(22.06)</b>	<b>(52.54)</b>	-	<b>(20.93)</b>	-	<b>(49.57)</b>	<b>(34.32)</b>
Charged/ (credited):										
- to profit or loss #	(8.22)	95.87	(1.22)	(34.97)	5.19	-	(195.80)	(94.72)	30.02	(203.85)
- to other comprehensive income	-	-	-	-	(2.22)	-	-	-	-	(2.22)
<b>At 31 March 2020</b>	<b>93.90</b>	<b>95.87</b>	<b>7.44</b>	<b>(57.03)</b>	<b>(49.57)</b>	-	<b>(216.73)</b>	<b>(94.72)</b>	<b>(19.55)</b>	<b>(240.39)</b>
<b>At 1 April 2020</b>	<b>93.90</b>	<b>95.87</b>	<b>7.44</b>	<b>(57.03)</b>	<b>(49.57)</b>	-	<b>(216.73)</b>	<b>(94.72)</b>	<b>(19.55)</b>	<b>(240.39)</b>
Charged/ (credited):										
- to profit or loss #	(20.45)	(18.60)	19.37	2.90	4.00	-	90.91	9.37	(16.56)	70.94
- to other comprehensive income	-	-	-	-	0.78	-	-	-	-	0.78
<b>At 31 March 2021</b>	<b>73.45</b>	<b>77.27</b>	<b>26.81</b>	<b>(54.13)</b>	<b>(44.79)</b>	-	<b>(125.82)</b>	<b>(85.35)</b>	<b>(36.11)</b>	<b>(168.67)</b>
<b>At 1 April 2021</b>	<b>73.45</b>	<b>77.27</b>	<b>26.81</b>	<b>(54.13)</b>	<b>(44.79)</b>	-	<b>(125.82)</b>	<b>(85.35)</b>	<b>(36.11)</b>	<b>(168.67)</b>
Charged/ (credited):										
- to profit or loss #	(0.55)	5.04	4.06	7.80	(3.78)	-	(21.08)	(5.31)	(11.84)	(25.66)
- to other comprehensive income	-	-	-	-	(0.60)	-	-	-	-	(0.60)
<b>At 30 June 2021</b>	<b>72.90</b>	<b>82.31</b>	<b>30.87</b>	<b>(46.33)</b>	<b>(49.17)</b>	-	<b>(146.90)</b>	<b>(90.66)</b>	<b>(47.95)</b>	<b>(194.93)</b>

\* Others majorly includes Deferred Tax (Assets) on Unrealised Profit on Inventory which is offset by Deferred Tax Liabilities created on Undistributed earnings of Joint Venture.

# Deferred Tax Charge/ (Credit) for the period/ year excludes exchange (gain)/ loss of INR (1.00 Mn) (31 March 2021: INR 30.82 Mn, 31 March 2020: INR (13.65 Mn) and 31 March 2019: INR (0.21 Mn) on account of re-statement of period/ year end deferred tax assets and liabilities.

**(b) Income Tax Expense**

Particulars	30 June 2021	31 March 2021	31 March 2020	31 March 2019
<i>Current tax</i>				
Current tax on restated profits for the period/ year	68.28	374.84	150.35	154.99
Adjustments for current tax of prior periods	1.39	(2.03)	4.54	0.97
<b>Total current tax expense</b>	<b>69.67</b>	<b>372.81</b>	<b>154.89</b>	<b>155.96</b>
<i>Deferred tax</i>				
Decrease/ (increase) in deferred tax assets	(34.21)	90.62	(290.28)	41.38
(Decrease)/ increase in deferred tax liabilities	8.55	(19.68)	86.43	(59.28)
Exchange difference on translation	(1.00)	30.82	(13.65)	(0.21)
<b>Total deferred tax expense/ (benefit)</b>	<b>(26.66)</b>	<b>101.76</b>	<b>(217.50)</b>	<b>(18.11)</b>
<b>Total tax expense/ (credit)</b>	<b>43.01</b>	<b>474.57</b>	<b>(62.61)</b>	<b>137.85</b>

**(c) Reconciliation of tax expense and the accounting profit multiplied by tax rate:**

Particulars	30 June 2021	31 March 2021	31 March 2020	31 March 2019
Restated Profit before tax	161.83	1,838.62	592.43	464.55
<b>Tax on above calculated at rates applicable to holding company</b>	<b>40.73</b>	<b>462.74</b>	<b>207.01</b>	<b>160.78</b>
Tax effect of amounts which are not deductible (taxable) in calculating taxable income:				
Effect of Income exempt from taxation (10AA Exemption of SEZ, 80JJAA and 80 IA)	-	(0.21)	(100.29)	(69.24)
MAT credit entitlement under section 115 JAA being difference in tax payable under MAT and Normal Provision	-	-	-	(15.38)
Difference in overseas tax rate #	2.68	(27.22)	0.78	(12.71)
Items not deductible in tax	2.06	15.62	45.30	2.24
Items on which tax rate is different	0.84	3.14	2.90	3.47
Taxes for earlier years	1.39	(2.03)	4.54	0.97
Tax on undistributed profit of Joint Venture	(1.54)	9.13	(22.68)	(3.03)
Exempt income	(0.89)	(8.54)	(18.22)	(30.23)
Effect of Change in Tax Rate	-	4.18	-	-
Previously Unrecognised tax losses used to reduce deferred tax expenses*	(2.14)	-	(215.15)	-
Others	(0.12)	17.76	33.20	100.98
<b>Total tax expense/ (credit)</b>	<b>43.01</b>	<b>474.57</b>	<b>(62.61)</b>	<b>137.85</b>

# The statutory tax rate applicable to various entities in the group range from 17.00% to 31.20% (31 March 2021: 17.00% - 31.20% ; 31 March 2020: 17.00% - 34.94% and 31 March 2019: 17.00% - 34.61%)

\*Following a significant improvement in performance of a subsidiary, the group reviewed previously unrecognised tax losses and determined that it has now probable that taxable profits will be available against which the tax losses can be utilised. As a consequence, a deferred tax asset of INR 215.15 Mn was recognised for these losses in 31 March 2020.

**(d)** The Holding Company during the year ended 31 March 2021 have opted for the new tax regime under Section 115BAA of the Act, which provides a domestic company with an option to pay tax at a rate of 22.00% (effective rate of 25.17%). The lower rate shall be applicable subject to certain conditions, including that the total income should be computed without claiming specific deduction or exemptions.

The Holding Company has elected to exercise the option permitted under new tax rate regime during the financial year ended 31 March 2021 and accordingly remeasured deferred tax balances expected to reverse in future periods based on the revised applicable tax rate.

**(e)** Deferred taxes on fair value adjustments recognised in the Holding Company's standalone financial statements with respect to investment in preference shares of subsidiary has not been recognised due to uncertainty surrounding availability of future capital gains against which such capital loss can be offset.



**Note: 38 Employee benefits obligations**

**(i) Post-employment obligations**

**(a) Defined contribution plan**

The Group makes Provident Fund , Superannuation Fund and Other Fund contributions to defined contribution plans for qualifying employees. Under the Schemes, the Group is required to contribute a specified percentage of the payroll costs to fund the benefits. The contributions payable to these plans by the Group are at rates specified in the rules of the schemes.

	<u>30 June 2021</u>	<u>31 March 2021</u>	<u>31 March 2020</u>	<u>31 March 2019</u>
i) Contribution to Provident Fund *	4.39	16.01	15.78	14.86
ii) Contribution to Superannuation Fund *	2.19	7.08	7.05	6.89
iii) Contribution to Other Funds other than India*	7.11	27.10	27.61	29.32
	<b>13.69</b>	<b>50.19</b>	<b>50.44</b>	<b>51.07</b>

(\* ) recognised under 'Contribution to provident and other funds' in Note 33.

**(b) Defined benefit plan- Gratuity**

The Group provides for gratuity, a defined benefit retirement plan covering eligible employees. As per scheme, the Gratuity Trust fund managed by the Trust, makes payment to vested employees on retirement, death, incapacitation or termination of employment, of an amount based on the respective employee's eligible salary (half month's salary) depending upon the tenure of service subject to a revised maximum limit of amount payable under Payment of Gratuity Act. Liabilities with regard to the Gratuity plan are determined by actuarial valuation as set out in Note 2.17 based upon which, the Group makes contribution to the Gratuity fund.

**(ii) Other long term employee benefit plans**

The leave obligations cover the Group's liability for other long term benefits.

Compensated absences cover the Group's liability for sick and earned leave. As the Group does not have an unconditional right to defer the payment beyond 12 months the entire amount has been treated as current.

**(iii) Balance Sheet Recognition**

**(a) Gratuity**

The amounts recognised in the Restated Consolidated Statement of Assets and Liabilities and the movements in the net defined benefit obligation (Gratuity) over the period/ year are as follows:

Particulars	Present value of obligation	Fair value of plan assets	Net amount
<b>As at 1 April 2018</b>	<b>44.57</b>	<b>(12.02)</b>	<b>32.55</b>
Current service cost	5.10	-	5.10
Interest expense/ (income)	3.43	(0.92)	2.51
<b>Total amount recognised in restated consolidated statement of profit and loss</b>	<b>8.53</b>	<b>(0.92)</b>	<b>7.61</b>
<i>Remeasurements</i>			
Return on plan assets, excluding amounts included in interest expense/ (income)	-	(0.05)	(0.05)
Actuarial (gain)/loss from change in demographic assumptions	(0.04)	-	(0.04)
Actuarial (gain)/loss from change in financial assumptions	5.49	-	5.49
Actuarial (gain)/loss from unexpected experience	(0.53)	-	(0.53)
<b>Total amount recognised in restated other comprehensive (income)/ loss</b>	<b>4.92</b>	<b>(0.05)</b>	<b>4.87</b>
Employer contributions/ premium paid	-	(11.00)	(11.00)
Benefit payments	(5.22)	5.22	-
<b>As at 31 March 2019</b>	<b>52.80</b>	<b>(18.77)</b>	<b>34.03</b>

Particulars	Present value of obligation	Fair value of plan assets	Net amount
<b>As at 1 April 2019</b>	<b>52.80</b>	<b>(18.77)</b>	<b>34.03</b>
Current service cost	6.18	-	6.18
Interest expense/ (income)	4.01	(1.42)	2.59
<b>Total amount recognised in restated consolidated statement of profit and loss</b>	<b>10.19</b>	<b>(1.42)</b>	<b>8.77</b>
<i>Remeasurements</i>			
Return on plan assets, excluding amounts included in interest expense/ (income)	-	(0.67)	(0.67)
Actuarial (gain)/ loss from change in demographic assumptions	(0.42)	-	(0.42)
Actuarial (gain)/ loss from change in financial assumptions	3.19	-	3.19
Actuarial (gain)/ loss from unexpected experience	4.26	-	4.26
<b>Total amount recognised in restated other comprehensive (income)/ loss</b>	<b>7.03</b>	<b>(0.67)</b>	<b>6.36</b>
Acquisition Cost	0.05	-	0.05
Employer contributions/ premium paid	-	(30.00)	(30.00)
Benefit payments	(12.69)	12.69	-
<b>As at 31 March 2020</b>	<b>57.38</b>	<b>(38.17)</b>	<b>19.21</b>

(All amounts in INR million, unless otherwise stated)

Particulars	Present value of obligation	Fair value of plan assets	Net amount
<b>As at 1 April 2020</b>	<b>57.38</b>	<b>(38.17)</b>	<b>19.21</b>
Current service cost	6.83	-	6.83
Interest expense/ (income)	3.79	(2.52)	1.27
<b>Total amount recognised in restated consolidated statement of profit and loss</b>	<b>10.62</b>	<b>(2.52)</b>	<b>8.10</b>
<i>Remeasurements</i>			
Return on plan assets, excluding amounts included in interest expense/ (income)	-	(0.01)	(0.01)
Actuarial (gain)/ loss from change in Demographic assumptions	-	-	-
Actuarial (gain)/ loss from change in financial assumptions	(2.10)	-	(2.10)
Actuarial (gain)/ loss from unexpected experience	(1.00)	-	(1.00)
<b>Total amount recognised in restated other comprehensive (income)/ loss</b>	<b>(3.10)</b>	<b>(0.01)</b>	<b>(3.11)</b>
Employer contributions/ premium paid	-	(0.03)	(0.03)
Benefit payments	(2.73)	2.73	-
<b>As at 31 March 2021</b>	<b>62.17</b>	<b>(38.00)</b>	<b>24.17</b>

Particulars	Present value of obligation	Fair value of plan assets	Net amount
<b>As at 1 April 2021</b>	<b>62.17</b>	<b>(38.00)</b>	<b>24.17</b>
Current service cost	1.24	-	1.24
Interest expense/ (income)	1.07	(0.66)	0.41
<b>Total amount recognised in restated consolidated statement of profit and loss</b>	<b>2.31</b>	<b>(0.66)</b>	<b>1.65</b>
<i>Remeasurements</i>			
Return on plan assets, excluding amounts included in interest expense/ (income)	-	0.00 <sup>^</sup>	0.00 <sup>^</sup>
Actuarial (gain)/ loss from change in Demographic assumptions	-	-	-
Actuarial (gain)/ loss from change in financial assumptions	-	-	-
Actuarial (gain)/ loss from unexpected experience	2.40	-	2.40
<b>Total amount recognised in restated other comprehensive (income)/ loss</b>	<b>2.40</b>	<b>-</b>	<b>2.40</b>
Employer contributions/ premium paid	-	-	-
Benefit payments	(0.07)	0.07	-
<b>As at 30 June 2021</b>	<b>66.81</b>	<b>(38.59)</b>	<b>28.22</b>

<sup>^</sup>Amount is below the rounding off norm adopted by the Group

**(iv) Significant estimates: actuarial assumptions**

The significant actuarial assumptions were as follows:

Particulars	30 June 2021	31 March 2021	31 March 2020	31 March 2019
Discount Rate	6.90%	6.90%	6.60%	7.60%
Rate of Salary Increase	8.50%	8.50%	8.50%	9.00%
Rate of Employee Turnover				
Upto 30 years	9.00%	9.00%	9.00%	7.00%
From 31 years to 44 years	4.00%	4.00%	4.00%	3.00%
More than 44 years	2.00%	2.00%	2.00%	2.00%
Mortality Rate During Employment	IALM 12-14 Ultimate	IALM 12-14 Ultimate	IALM 12-14 Ultimate	IALM 06-08 Ultimate

The estimates of future salary increases, considered in actuarial valuation, take account of inflation, seniority, promotion and other relevant factors.

The expected return on plan assets is determined after taking into consideration composition of the plan assets held, assessed risks of assets management, historical results of the return on plan assets, and other relevant factors.

**(v) Sensitivity analysis**

The sensitivity of the defined benefit obligation to changes in the weighted principal assumptions is:

Particulars	% change compared to base due to sensitivity							
	30 June 2021		31 March 2021		31 March 2020		31 March 2019	
	Decrease	Increase	Decrease	Increase	Decrease	Increase	Decrease	Increase
Discount Rate (- / + 1%)	<b>11.88%</b> 7.94	<b>-9.96%</b> (6.65)	<b>12.01%</b> 7.47	<b>-10.60%</b> (6.25)	<b>12.22%</b> 7.01	<b>-10.20%</b> (5.85)	<b>11.66%</b> 6.15	<b>-9.71%</b> (5.12)
Salary Growth Rate (- / + 1%)	<b>-9.38%</b> (6.27)	<b>10.52%</b> 7.03	<b>-9.75%</b> (6.06)	<b>10.69%</b> 6.65	<b>-9.95%</b> (5.71)	<b>11.34%</b> 6.51	<b>-9.51%</b> (5.02)	<b>10.85%</b> 5.73
Attrition Rate (- / + 50%)	<b>2.54%</b> 1.70	<b>-1.99%</b> (1.33)	<b>2.61%</b> 1.62	<b>-2.04%</b> (1.26)	<b>3.20%</b> 1.84	<b>-2.49%</b> (1.43)	<b>2.00%</b> 1.05	<b>-1.63%</b> (0.86)
Mortality Rate (- / + 10%)	<b>0.18%</b> 0.12	<b>-0.17%</b> (0.12)	<b>0.19%</b> 0.12	<b>-0.19%</b> (0.12)	<b>0.24%</b> 0.14	<b>-0.24%</b> (0.14)	<b>0.19%</b> 0.10	<b>-0.18%</b> (0.10)

The above sensitivity analyses are based on a change in an assumption while holding all other assumptions constant. In practice, this is unlikely to occur, and changes in some of the assumptions may be correlated. When calculating the sensitivity of the defined benefit obligation to significant actuarial assumptions the same method (present value of the defined benefit obligation calculated with the projected unit credit method at the end of the reporting period) has been applied as when calculating the defined benefit liability recognised in the Restated Consolidated Statement of Assets and Liabilities.

The methods and types of assumptions used in preparing the sensitivity analysis did not change compared to the prior periods.

**(vi) The major categories of plans assets**

Particulars	30 June 2021	31 March 2021	31 March 2020	31 March 2019
Funds Managed by Insurer	97.75%	98.14%	94.97%	89.31%
Bank balance	2.25%	1.86%	5.03%	10.69%
<b>Total</b>	<b>100.00%</b>	<b>100.00%</b>	<b>100.00%</b>	<b>100.00%</b>

**(vii) Risk exposure**

Valuations are performed on certain basic set of pre-determined assumptions and other regulatory framework which may vary overtime. Thus, the Group is exposed to various risks in providing the above gratuity benefit which are as follows:

*Interest Risk:*

The plan exposes the Group to the risk of fall in interest rates. A fall in interest rates will result in an increase in the ultimate cost of providing the above benefit and will thus result in an increase in the value of the liability (as shown in Restated Consolidated Financial Information).

*Liquidity Risk:*

This is the risk that the Group is not able to meet the short-term gratuity payouts. This may arise due to non-availability of enough cash/ cash equivalent to meet the liabilities or holding of illiquid assets not being sold in time.

*Salary Escalation Risk:*

The present value of the defined benefit plans calculated with the assumption of salary increase rate of plan participants in future. Deviation in the rate of increase of salary in future for plan participants from the rate of increase in salary used to determine the present value of obligation will have a bearing on the plan's liability.

*Demographic Risk:*

The Group has used certain mortality and attrition assumptions in valuation of the liability. The Group is exposed to the risk of actual experience turning out to be worse compared to the assumption.

*Regulatory Risk:*

Gratuity benefit is paid in accordance with the requirements of the Payment of Gratuity Act, 1972 (as amended from time to time). There is a risk of change in regulations requiring higher gratuity payouts (e.g. Increase in the maximum limit on gratuity of INR 2.00 Mn).

**(viii) Defined benefit liability and employer contributions**

The Group expects to contribute INR 28.22 Mn to the funded retiring gratuity plan within the next twelve months (31 March 2021: INR 24.17 Mn; 31 March 2020: INR 19.21 Mn and 31 March 2019: INR 34.03 Mn)

The weighted average duration of the defined benefit obligation is 12 years (31 March 2021: 12 years ; 31 March 2020: 12 years and 31 March 2019: 11 years).

Note: 39 Fair value measurements

Financial instruments by category

Particulars	30 June 2021		31 March 2021		31 March 2020		31 March 2019	
	FVTPL	Amortised cost	FVTPL	Amortised cost	FVTPL	Amortised cost	FVTPL	Amortised cost
<b>Financial assets</b>								
Investments								
- Mutual funds	1,878.98	-	1,743.77	-	1,333.21	-	533.54	-
Trade receivables	-	1,671.42	-	2,203.95	-	1,828.06	-	2,005.45
Cash and cash equivalents	-	645.77	-	478.70	-	368.63	-	192.64
Other bank balances	-	9.80	-	5.40	-	0.48	-	4.38
Other financial assets	-	51.88	-	38.47	-	43.64	-	44.20
Derivative Assets	100.57	-	106.81	-	114.62	-	59.71	-
<b>Total financial assets</b>	<b>1,979.55</b>	<b>2,378.87</b>	<b>1,850.58</b>	<b>2,726.52</b>	<b>1,447.83</b>	<b>2,240.81</b>	<b>593.25</b>	<b>2,246.67</b>
<b>Financial liabilities</b>								
Borrowings	-	1,842.38	-	1,878.02	-	2,439.34	-	2,126.90
Derivative liabilities	97.47	-	111.86	-	181.12	-	38.85	-
Trade payables	-	1,174.44	-	987.10	-	652.96	-	806.83
Other financial liabilities	-	16.94	-	21.07	-	26.36	-	32.20
<b>Total financial liabilities</b>	<b>97.47</b>	<b>3,033.76</b>	<b>111.86</b>	<b>2,886.19</b>	<b>181.12</b>	<b>3,118.66</b>	<b>38.85</b>	<b>2,965.93</b>

(All amounts in INR million, unless otherwise stated)

**Note: 39 Fair value measurements (continued)**

**(i) Fair value hierarchy**

This section explains the judgements and estimates made in determining the fair values of the financial instruments that are (a) recognised and measured at fair value and (b) measured at amortised cost and for which fair values are disclosed in the Restated Consolidated Financial Information. To provide an indication about the reliability of the inputs used in determining fair value, the Group has classified its financial instruments into the three levels prescribed under the accounting standard. An explanation of each level follows underneath the table.

Financial assets and liabilities measured at fair value - recurring fair value measurements At 30 June 2021	Level 1	Level 2	Level 3	Total
<b>Financial assets</b>				
Investments				
- Mutual funds	1,695.10	183.88	-	1,878.98
Derivative financial assets	-	100.57	-	100.57
<b>Total financial assets</b>	<b>1,695.10</b>	<b>284.45</b>	<b>-</b>	<b>1,979.55</b>
<b>Financial liabilities</b>				
Derivative financial liabilities	-	97.47	-	97.47
<b>Total financial liabilities</b>	<b>-</b>	<b>97.47</b>	<b>-</b>	<b>97.47</b>

Financial assets and liabilities measured at fair value - recurring fair value measurements At 31 March 2021	Level 1	Level 2	Level 3	Total
<b>Financial assets</b>				
Investments				
- Mutual funds	1,561.92	181.85	-	1,743.77
Derivative financial assets	-	106.81	-	106.81
<b>Total financial assets</b>	<b>1,561.92</b>	<b>288.66</b>	<b>-</b>	<b>1,850.58</b>
<b>Financial liabilities</b>				
Derivative financial liabilities	-	111.86	-	111.86
<b>Total financial liabilities</b>	<b>-</b>	<b>111.86</b>	<b>-</b>	<b>111.86</b>

Financial assets and liabilities measured at fair value - recurring fair value measurements At 31 March 2020	Level 1	Level 2	Level 3	Total
<b>Financial assets</b>				
Investments				
- Mutual funds	1,166.63	166.58	-	1,333.21
Derivative financial assets	-	114.62	-	114.62
<b>Total financial assets</b>	<b>1,166.63</b>	<b>281.20</b>	<b>-</b>	<b>1,447.83</b>
<b>Financial liabilities</b>				
Derivative financial liabilities	-	181.12	-	181.12
<b>Total financial liabilities</b>	<b>-</b>	<b>181.12</b>	<b>-</b>	<b>181.12</b>

Financial assets and liabilities measured at fair value - recurring fair value measurements At 31 March 2019	Level 1	Level 2	Level 3	Total
<b>Financial assets</b>				
Investments				
- Mutual funds	382.15	151.39	-	533.54
Derivative financial assets	-	59.71	-	59.71
<b>Total financial assets</b>	<b>382.15</b>	<b>211.10</b>	<b>-</b>	<b>593.25</b>
<b>Financial liabilities</b>				
Derivative financial liabilities	-	38.85	-	38.85
<b>Total financial liabilities</b>	<b>-</b>	<b>38.85</b>	<b>-</b>	<b>38.85</b>

(All amounts in INR million, unless otherwise stated)

**Level 1:** Level 1 hierarchy includes financial instruments measured using quoted prices. Level 1 inputs are quoted prices in active markets for identical assets or liabilities that the entity can access at the measurement date. This includes mutual funds that are actively traded at NAVs.

**Level 2:** The fair value of financial instruments that are not traded in an active market (for example, over-the-counter derivatives, fixed maturity mutual funds) is determined using valuation techniques which maximise the use of observable market data and rely as little as possible on entity-specific estimates. If all significant inputs required to fair value an instrument are observable, the instrument is included in level 2.

**Level 3:** If one or more of the significant inputs is not based on observable market data, the instrument is included in level 3. This is generally the case for unlisted equity securities.

There are no transfers between levels 1, 2 and 3 during the period/ year ended 30 June 2021, 31 March 2021, 31 March 2020 and 31 March 2019.

**(ii) Valuation technique used to determine fair value**

- (a) Derivatives are fair valued using market observable rates and published prices together with forecasted cash flow information where applicable.  
(b) Investments (Mutual funds) carried at fair value are generally based on available NAVs.

(c) Fair value of borrowings is estimated by discounting expected future cash flows. The carrying amounts of other borrowings with floating rate of interest are considered to be close to the fair value.

(d) The carrying amounts of remaining financial assets and liabilities are considered to be the same as their fair values.

(e) Management uses its best judgement in estimating the fair value of its financial instruments. However, there are inherent limitations in any estimation technique. Therefore, for substantially all financial instruments, the fair value estimates presented below are not necessarily indicative of the amounts that the Group could have realised or paid in sale transactions as of respective dates. As such, fair value of financial instruments subsequent to the reporting dates may be different from the amounts reported at each reporting date.

**(iii) Fair value of financial assets and liabilities measured at amortised cost**

Particulars	30 June 2021		31 March 2021		31 March 2020		31 March 2019	
	Carrying amount	Fair value	Carrying amount	Fair value	Carrying amount	Fair value	Carrying amount	Fair value
<b>Financial liabilities</b>								
Borrowings	63.24	62.84	69.29	68.93	17.23	17.17	13.23	13.10
<b>Total financial liabilities</b>	<b>63.24</b>	<b>62.84</b>	<b>69.29</b>	<b>68.93</b>	<b>17.23</b>	<b>17.17</b>	<b>13.23</b>	<b>13.10</b>

**(iv) Transfer of financial assets**

The Group transfers certain trade receivables under discounting arrangements with banks and financial institutions. Some of such arrangements do not qualify for de-recognition due to recourse arrangement being in place. Consequently, the proceeds received from transfer are recorded as short-term borrowings from banks and financial institutions.

The carrying value of trade receivables not de-recognised along with the associated liabilities is as below:

Particulars	30 June 2021		31 March 2021		31 March 2020		31 March 2019	
	Carrying value of asset transferred	Carrying value associated liabilities	Carrying value of asset transferred	Carrying value associated liabilities	Carrying value of asset transferred	Carrying value associated liabilities	Carrying value of asset transferred	Carrying value associated liabilities
Trade receivables	63.99	63.99	25.50	25.50	119.81	119.81	91.02	91.02
<b>Total</b>	<b>63.99</b>	<b>63.99</b>	<b>25.50</b>	<b>25.50</b>	<b>119.81</b>	<b>119.81</b>	<b>91.02</b>	<b>91.02</b>



**Note: 40 Financial risk management**

The Group's activities expose it to a variety of financial risks: credit risk, liquidity risk and market risk (i.e. foreign currency risk, interest rate risk and price risk).

This note explains the sources of risk which the entity is exposed to and how the entity manages the risk:

Risk	Exposure arising from	Management
<i>Credit risk</i>	Cash and cash equivalents, trade receivables and contract assets and other financial assets measured at amortised cost.	Diversification of bank deposits and investments. Entering into transactions with customers of repute / customers having sound financial position.
<i>Liquidity risk</i>	Financial liabilities that are settled by delivering cash or another financial asset.	Projecting cash flows and considering the level of liquid assets necessary to meet the liabilities.
<i>Market risk – foreign exchange</i>	Future commercial transactions and recognised financial assets and liabilities not denominated in Indian rupee (INR).	Entering into forward contracts, options and interest rate swaps.
<i>Market risk – interest rate</i>	Long-term borrowings at variable rates.	Entering into derivative contracts such as interest rate swaps and currency swaps.
<i>Market risk – security price risk</i>	Investments in mutual funds.	Portfolio diversification.

**(A) Credit risk**

Credit risk is the risk that counterparty will not meet its obligations under a financial instrument or customer contract, leading to a financial loss. The Group is exposed to credit risk from its operating activities (primarily trade receivables and contract assets) including deposits with banks, investments and other financial instruments. The Group periodically monitors the recoverability and credit risks of its other financial assets including security deposits and other receivables.

**i) Trade receivables and contract assets**

Customer credit risk is managed by the management subject to the Group's established policy, procedures and control relating to customer credit risk management. Trade receivables and contract assets are non-interest bearing. Outstanding customer receivables are regularly monitored.

At each reporting date the Group measures loss allowance for certain class of financial assets based on historical trend industry practice and the business environment in which the Group operates.

**ii) Financial instruments and cash deposits**

Credit risk from balances with banks and investments is managed by the Group in accordance with the Group's policy. Investments of surplus funds are made only with approved counterparties and within credit limits assigned to each counterparty. The limits are set to minimise the concentration of risks and therefore mitigate financial loss through counterparty's potential failure to make payments.

The Group's maximum exposure to credit risk for the components of the balance sheet at 30 June 2021, 31 March 2021, 31 March 2020 and 31 March 2019 is the carrying amounts of trade receivables and contract assets, investments, balances with bank and other financial assets.

**Provision for expected credit loss**

In determination of the allowance for credit losses on receivables, the Group has used a practical experience by computing the expected credit losses based on provision matrix, which has taken into account historical credit loss experience and adjusted for forward looking information. The Group also analyses all its receivables periodically for recoverability assessment and wherever they have analysed that the receivable may be credit impaired on account of non recoverability, loss allowance on such receivables have been provided in full.

Details of allowances for expected credit loss are provided hereunder :-

Particulars	For the three months period ended 30 June 2021	For the year ended 31 March 2021	For the year ended 31 March 2020	For the year ended 31 March 2019
At the beginning of the period/ year	113.93	96.58	76.87	53.75
Provisions created/ (written back) during the period/ year (net) (a)	(35.03)	11.77	22.30	24.27
Adjustments (Exchange Difference)	1.48	5.58	(2.59)	(1.15)
<b>Closing at the end of the period/ year</b>	<b>80.38</b>	<b>113.93</b>	<b>96.58</b>	<b>76.87</b>
Bad debts and advances written off (b)	41.17	45.62	26.42	14.29
Total Charge to Restated Consolidated Statement of Profit & Loss (a+b)	6.14	57.39	48.72	38.56

**Note: 40 Financial risk management (continued)**

**(B) Liquidity risk**

Liquidity risk is the risk that an entity will encounter difficulty in meeting obligations associated with financial liabilities that are settled by delivering cash or another financial asset.

Prudent liquidity risk management implies maintaining sufficient cash and marketable securities and the availability of funding through an adequate amount of committed credit facilities to meet obligations when due and to close out market positions. Due to the dynamic nature of the underlying businesses, group treasury maintains flexibility in funding by maintaining availability under committed credit lines. Management monitors rolling forecasts of the Group's liquidity position and cash and cash equivalents on the basis of expected cash flows.

**(i) Maturities of financial liabilities**

The tables below analyse the group's financial liabilities into relevant maturity groupings based on their contractual maturities:

The amounts disclosed in the table are the contractual undiscounted cash flows:

Contractual maturities of financial liabilities 30 June 2021	Carrying Value	Contractual Cash Flows	Less than 1 year	1 - 3 years	3 - 5 years	More than 5 years
<b>Non-derivatives</b>						
Borrowings	1,842.38	1,842.38	1,025.56	522.76	266.19	27.87
Lease Liabilities	337.46	578.13	96.62	96.51	58.15	326.85
Other financial liabilities	10.46	10.46	10.46	-	-	-
Trade payables	1,174.44	1,174.44	1,174.44	-	-	-
Interest payable on above borrowings**	6.48	129.91	54.57	58.55	16.44	0.35
<b>Total non-derivative financial liabilities</b>	<b>3,371.22</b>	<b>3,735.32</b>	<b>2,361.65</b>	<b>677.82</b>	<b>340.78</b>	<b>355.07</b>
<b>Derivatives (net settled)</b>						
Foreign exchange forward/ option/ swap contracts	97.47	97.47	14.81	18.37	32.64	31.65
<b>Total derivative liabilities</b>	<b>97.47</b>	<b>97.47</b>	<b>14.81</b>	<b>18.37</b>	<b>32.64</b>	<b>31.65</b>

\*\* Based on closing rates

Contractual maturities of financial liabilities 31 March 2021	Carrying Value	Contractual Cash Flows	Less than 1 year	1 - 3 years	3 - 5 years	More than 5 years
<b>Non-derivatives</b>						
Borrowings	1,878.02	1,878.02	1,018.52	499.26	305.42	54.82
Lease Liabilities	318.70	558.24	83.92	88.15	60.49	325.68
Other financial liabilities	13.89	13.89	13.89	-	-	-
Trade payables	987.10	987.10	987.10	-	-	-
Interest payable on above borrowings**	7.18	279.14	110.79	144.82	22.49	1.04
<b>Total non-derivative financial liabilities</b>	<b>3,204.89</b>	<b>3,716.39</b>	<b>2,214.22</b>	<b>732.23</b>	<b>388.40</b>	<b>381.54</b>
<b>Derivatives (net settled)</b>						
Foreign exchange forward/ option/ swap contracts	111.86	111.86	22.63	19.65	35.30	34.28
<b>Total derivative liabilities</b>	<b>111.86</b>	<b>111.86</b>	<b>22.63</b>	<b>19.65</b>	<b>35.30</b>	<b>34.28</b>

\*\* Based on closing rates

Contractual maturities of financial liabilities 31 March 2020	Carrying Value	Contractual Cash Flows	Less than 1 year	1 - 3 years	3 - 5 years	More than 5 years
<b>Non-derivatives</b>						
Borrowings	2,439.34	2,439.34	1,488.27	389.17	403.05	158.85
Lease Liabilities	340.70	559.70	96.12	112.05	64.63	286.90
Other financial liabilities	16.19	16.19	16.19	-	-	-
Trade payables	652.96	652.96	652.96	-	-	-
Interest payable on above borrowings**	10.17	193.80	64.66	83.41	38.49	7.24
<b>Total non-derivative financial liabilities</b>	<b>3,459.36</b>	<b>3,861.99</b>	<b>2,318.20</b>	<b>584.63</b>	<b>506.17</b>	<b>452.99</b>
<b>Derivatives (net settled)</b>						
Foreign exchange forward/ option/ swap contracts	181.12	181.12	48.05	27.85	58.80	46.42
<b>Total derivative liabilities</b>	<b>181.12</b>	<b>181.12</b>	<b>48.05</b>	<b>27.85</b>	<b>58.80</b>	<b>46.42</b>

\*\* Based on closing rates

Contractual maturities of financial liabilities 31 March 2019	Carrying Value	Contractual Cash Flows	Less than 1 year	1 - 3 years	3 - 5 years	More than 5 years
<b>Non-derivatives</b>						
Borrowings	2,126.90	2,126.90	1,529.56	428.38	117.09	51.87
Lease Liabilities	308.19	562.81	67.46	117.72	41.97	335.66
Other financial liabilities	22.59	22.59	22.59	-	-	-
Trade payables	806.83	806.83	806.83	-	-	-
Interest payable on above borrowings**	9.61	110.72	48.06	45.33	15.07	2.26
<b>Total non-derivative financial liabilities</b>	<b>3,274.12</b>	<b>3,629.85</b>	<b>2,474.50</b>	<b>591.43</b>	<b>174.13</b>	<b>389.79</b>
<b>Derivatives (net settled)</b>						
Foreign exchange forward/ option/ swap contracts	38.85	38.85	5.11	2.36	11.87	19.51
<b>Total derivative liabilities</b>	<b>38.85</b>	<b>38.85</b>	<b>5.11</b>	<b>2.36</b>	<b>11.87</b>	<b>19.51</b>

\*\* Based on closing rates

**Note: 40 Financial risk management (continued)**  
**(C) Market risk**

**(i) Foreign currency risk**

The Group deals with foreign currency bank accounts, trade receivables and contract assets, borrowings, trade payables and is therefore exposed to foreign exchange risk associated with exchange rate movement.

The Group operates internationally and portion of the business is transacted in several currencies and consequently the Group is exposed to foreign exchange risk through its sales in overseas and purchases from overseas suppliers in various foreign currencies. Foreign currency exchange rate exposure is partly balanced by purchasing of goods, commodities and services in the respective currencies. The Group primarily uses derivatives to hedge its risk against foreign currency balances of borrowings, trade payables and trade receivables and contract assets. Such exposures are managed within approved policy parameters utilising foreign exchange forward contracts and options. Further, the Group also has variable interest rate loan in foreign currency. To manage its risk against interest rate movements the Group has taken an interest rate swap. The Group also enter into derivative contracts to hedge forecast sales and purchase transactions using forward contracts.

**Foreign currency risk exposure**

The Group's exposure to foreign currency risk for major currencies at the end of the reporting period expressed in INR (foreign currency amount multiplied by closing rate), are as follows:-

Particulars	30 June 2021						
	AUD	CAD	EUR	USD	ZAR	GBP	GHS
<b>Financial assets</b>							
Trade receivables and contract assets	0.12	-	164.03	603.00	-	-	0.29
Bank balances	0.16	0.02	0.74	182.87	-	0.30	1.17
<b>Offset by derivatives:</b>							
Foreign exchange forward contracts	(235.24)	(149.03)	(88.40)	(680.52)	-	-	-
<b>Net exposure to foreign currency risk (assets)</b>	<b>(234.96)</b>	<b>(149.01)</b>	<b>76.37</b>	<b>105.35</b>	<b>-</b>	<b>0.30</b>	<b>1.46</b>
<b>Financial liabilities</b>							
Trade and other payables	-	(0.54)	(191.80)	(235.02)	-	-	(25.00)
Other financial liabilities	-	-	(0.03)	(5.54)	-	-	-
Borrowings	-	-	(62.86)	(1,123.31)	-	-	-
<b>Offset by derivatives:</b>							
Foreign exchange forward contracts/ Foreign Currency option contracts	-	-	-	1,025.75	-	-	-
<b>Net exposure to foreign currency risk (liabilities)</b>	<b>-</b>	<b>(0.54)</b>	<b>(254.69)</b>	<b>(338.12)</b>	<b>-</b>	<b>-</b>	<b>(25.00)</b>
<b>Net exposure</b>	<b>(234.96)</b>	<b>(149.55)</b>	<b>(178.32)</b>	<b>(232.77)</b>	<b>-</b>	<b>0.30</b>	<b>(23.54)</b>
Particulars	31 March 2021						
	AUD	CAD	EUR	USD	ZAR	GBP	GHS
<b>Financial assets</b>							
Trade receivables and contract assets	-	-	250.91	685.13	-	4.03	-
Bank balances	9.15	0.02	0.60	105.10	-	0.39	0.20
<b>Offset by derivatives:</b>							
Foreign exchange forward contracts	(334.96)	(174.80)	(180.32)	(716.70)	-	-	-
<b>Net exposure to foreign currency risk (assets)</b>	<b>(325.81)</b>	<b>(174.78)</b>	<b>71.19</b>	<b>73.53</b>	<b>-</b>	<b>4.42</b>	<b>0.20</b>
<b>Financial liabilities</b>							
Trade and other payables	-	-	(145.74)	(258.55)	(0.17)	(0.06)	(39.91)
Other financial liabilities	-	-	-	(5.01)	-	-	-
Borrowings	-	-	-	(1,148.28)	-	-	-
<b>Offset by derivatives:</b>							
Foreign exchange forward contracts/ Foreign Currency option contracts	-	-	-	1,076.40	-	-	-
<b>Net exposure to foreign currency risk (liabilities)</b>	<b>-</b>	<b>-</b>	<b>(145.74)</b>	<b>(335.44)</b>	<b>(0.17)</b>	<b>(0.06)</b>	<b>(39.91)</b>
<b>Net exposure</b>	<b>(325.81)</b>	<b>(174.78)</b>	<b>(74.55)</b>	<b>(261.91)</b>	<b>(0.17)</b>	<b>4.36</b>	<b>(39.71)</b>
Particulars	31 March 2020						
	AUD	CAD	EUR	USD	ZAR	GBP	GHS
<b>Financial assets</b>							
Trade receivables and contract assets	25.02	-	361.95	512.52	-	0.02	-
Bank balances	1.21	0.02	0.99	15.28	-	0.30	0.55
<b>Offset by derivatives:</b>							
Foreign exchange forward contracts	(196.69)	(164.23)	(327.37)	(691.27)	-	-	-
<b>Net exposure to foreign currency risk (assets)</b>	<b>(170.46)</b>	<b>(164.21)</b>	<b>35.57</b>	<b>(163.47)</b>	<b>-</b>	<b>0.32</b>	<b>0.55</b>
<b>Financial liabilities</b>							
Trade and other payables	-	-	(8.50)	(39.73)	(1.43)	-	(5.10)
Other financial liabilities	(5.57)	-	(0.40)	(7.03)	-	-	-
Borrowings	-	-	(191.56)	(1,230.23)	-	-	-
<b>Offset by derivatives:</b>							
Foreign exchange forward contracts/ Foreign Currency option contracts	-	-	64.12	1,051.74	-	-	-
<b>Net exposure to foreign currency risk (liabilities)</b>	<b>(5.57)</b>	<b>-</b>	<b>(136.34)</b>	<b>(225.25)</b>	<b>(1.43)</b>	<b>-</b>	<b>(5.10)</b>
<b>Net exposure</b>	<b>(176.03)</b>	<b>(164.21)</b>	<b>(100.77)</b>	<b>(388.72)</b>	<b>(1.43)</b>	<b>0.32</b>	<b>(4.55)</b>
Particulars	31 March 2019						
	AUD	CAD	EUR	USD	ZAR	GBP	GHS
<b>Financial assets</b>							
Trade receivables and contract assets	30.60	-	252.59	917.26	-	0.91	-
Bank balances	0.02	0.05	0.01	17.09	-	0.31	3.48
<b>Offset by derivatives:</b>							
Foreign exchange forward contracts	(202.97)	(200.54)	(225.25)	(1,124.31)	(1.73)	-	-
<b>Net exposure to foreign currency risk (assets)</b>	<b>(172.35)</b>	<b>(200.49)</b>	<b>27.35</b>	<b>(189.96)</b>	<b>(1.73)</b>	<b>1.22</b>	<b>3.48</b>
<b>Financial liabilities</b>							
Trade and other payables	(0.05)	-	(25.72)	(168.71)	(0.15)	-	(8.96)
Other financial liabilities	(5.92)	-	(0.03)	(0.49)	-	-	-
Borrowings	-	-	(13.59)	(984.76)	-	-	-
<b>Offset by derivatives:</b>							
Foreign exchange forward contracts/ Foreign Currency option contracts	-	-	-	325.03	-	-	-
<b>Net exposure to foreign currency risk (liabilities)</b>	<b>(5.97)</b>	<b>-</b>	<b>(39.34)</b>	<b>(828.93)</b>	<b>(0.15)</b>	<b>-</b>	<b>(8.96)</b>
<b>Net exposure</b>	<b>(178.32)</b>	<b>(200.49)</b>	<b>(11.99)</b>	<b>(1,018.89)</b>	<b>(1.88)</b>	<b>1.22</b>	<b>(5.48)</b>

**Sensitivity**

The sensitivity of profit or loss to changes in the exchange rates arises mainly from foreign currency denominated financial instruments.

Particulars	Impact on profit before tax						
	AUD	CAD	EUR	USD	ZAR	GBP	GHS
<b>30 June 2021</b>							
INR appreciates by 5%*	11.75	7.48	8.92	11.64	-	(0.01)	1.18
INR depreciates by 5%*	(11.75)	(7.48)	(8.92)	(11.64)	-	0.01	(1.18)
<b>31 March 2021</b>							
INR appreciates by 5%*	16.29	8.74	3.73	13.10	0.01	(0.22)	1.99
INR depreciates by 5%*	(16.29)	(8.74)	(3.73)	(13.10)	(0.01)	0.22	(1.99)
<b>31 March 2020</b>							
INR appreciates by 5%*	8.80	8.21	5.04	19.44	0.07	(0.02)	0.23
INR depreciates by 5%*	(8.80)	(8.21)	(5.04)	(19.44)	(0.07)	0.02	(0.23)
<b>31 March 2019</b>							
INR appreciates by 5%*	8.92	10.02	0.60	50.94	0.09	(0.06)	0.27
INR depreciates by 5%*	(8.92)	(10.02)	(0.60)	(50.94)	(0.09)	0.06	(0.27)

\* Holding all other variables constant

**(ii) Price risk**

**(a) Exposure**

Security price risk is the risk that the fair value of a financial instrument will fluctuate due to change in market traded prices. The Group invests its surplus funds primarily in liquid schemes of mutual funds (debt instruments) which are categorised as low risk products from liquidity and interest rate perspectives. The carrying amount of the Group investments are designated as at fair value through profit or loss at the end of the reporting period. [Refer Note 6 and 12].

**(b) Sensitivity**

The Group has invested in growth model of these securities as at the period/ year end. The sensitivity analysis below is presented with reference to changes in NAV of these securities:-

Particulars	Impact on restated profit before tax			
	30 June 2021	31 March 2021	31 March 2020	31 March 2019
NAV - Increases by 1%*	18.79	17.44	6.68	4.88
NAV - Decreases by 1%*	(18.79)	(17.44)	(6.68)	(4.88)

\* Holding all other variables constant

**Note: 40 Financial risk management (continued)**

**(iii) Interest rate risk**

Interest rate risk is the risk that the fair value or future cash flows of a financial instrument will fluctuate because of changes in market interest rates. The Group's exposure to the risk of changes in market interest rates relates primarily to the Group's long-term debt obligations with floating interest rates.

The Group's main interest rate risk arises from long-term borrowings with variable rates, which expose the Group to cash flow interest rate risk.

The Group's fixed rate borrowings are carried at amortised cost. They are therefore not subject to interest rate risk as defined in Ind AS 107, since neither the carrying amount nor the future cash flows will fluctuate because of a change in market interest rates.

**(a) Interest rate risk exposure**

**On Financial Liabilities:**

The exposure of the Group's financial liabilities to interest rate risk is as follows:

Particulars	30 June 2021	31 March 2021	31 March 2020	31 March 2019
Variable rate borrowings	1,779.14	1,808.73	2,422.11	2,113.67
Fixed rate borrowings	63.24	69.29	17.23	13.23
<b>Total borrowings</b>	<b>1,842.38</b>	<b>1,878.02</b>	<b>2,439.34</b>	<b>2,126.90</b>

**(b) Sensitivity**

Profit or loss is sensitive to higher/ lower interest expense from borrowings as a result of changes in interest rates as below:

Particulars	Impact on restated profit before tax			
	30 June 2021	31 March 2021	31 March 2020	31 March 2019
Interest expense rates – increase by 50 basis points (50 bps)*	(8.90)	(9.04)	(12.11)	(10.57)
Interest expense rates – decrease by 50 basis points (50 bps)*	8.90	9.04	12.11	10.57

\* Holding all other variables constant

**Note: 41 Capital management**

**(a) Risk management**

The Group's objectives when managing capital are to:

- safeguard their ability to continue as a going concern, so that they can continue to provide returns for shareholders and benefits for other stakeholders, and
- maintain an optimal capital structure to reduce the cost of capital.

The capital structure of the Group is based on management's judgement of the appropriate balance of key elements in order to meet its strategic and day-to-day needs. The Group manages its capital structure and makes adjustments in light of changes in economic conditions and the requirements of the financial covenants. The funding requirement is met through a mixture of equity, long term borrowings and short term borrowings.

In order to maintain or adjust the capital structure, the Group may adjust the amount of dividends paid to shareholders, return capital to shareholders, issue new shares or sell assets to reduce debt.

The Group's policy is to maintain a stable and strong capital structure with a focus on total equity so as to maintain investor, creditors and market confidence and to sustain future development and growth of its business. The Group will take appropriate steps in order to maintain, or if necessary adjust, its capital structure.

**(b) Dividends paid and proposed**

Particulars	30 June 2021	31 March 2021	31 March 2020	31 March 2019
<b>Preference shares</b>				
Dividend on Preference shares	-	0.00 <sup>^</sup>	0.00 <sup>^</sup>	0.00 <sup>^</sup>
Tax on dividend on preference shares	-	-	-	0.00 <sup>^</sup>

<sup>^</sup>Amount is below the rounding off norm adopted by the Group

**Net debt reconciliation**

This section sets out an analysis of debt and the movements in net debt for the current period

Particulars	30 June 2021	31 March 2021	31 March 2020	31 March 2019
Cash and cash equivalents	645.77	478.70	368.63	192.64
Non-current borrowings	(816.85)	(862.10)	(951.07)	(597.33)
Current borrowings	(797.17)	(800.72)	(1,370.37)	(1,285.00)
Current maturities of long term borrowings	(228.36)	(215.20)	(117.90)	(244.57)
Lease Liabilities	(337.46)	(318.70)	(340.70)	(308.19)
Net Derivative Liabilities (Swap and Option)	(2.47)	(16.62)	(47.51)	(11.74)
Interest accrued on long term borrowings	(5.78)	(6.23)	(6.85)	(5.69)
Interest accrued on short term borrowings	(0.70)	(0.95)	(3.32)	(3.92)
<b>Total</b>	<b>(1,543.02)</b>	<b>(1,741.82)</b>	<b>(2,469.09)</b>	<b>(2,263.80)</b>

Particulars	Other assets		Liabilities from financing activities			Total
	Cash and cash equivalents	Non-current borrowings	Current borrowings	Lease Liabilities	Net Derivative Liabilities (Swap and Option)	
<b>Net debt as at 1 April 2021</b>	<b>478.70</b>	<b>(1,083.53)</b>	<b>(801.67)</b>	<b>(318.70)</b>	<b>(16.62)</b>	<b>(1,741.82)</b>
Cash flows	168.00	47.75	8.27	-	-	224.02
Acquisition of lease	-	-	-	(37.58)	-	(37.58)
Principal repayment of lease	-	-	-	21.88	-	21.88
Interest expense	-	(13.43)	(8.53)	(6.54)	-	(28.50)
Interest paid	-	13.88	8.78	6.54	-	29.20
Payment on Derivative Settlement (net)	-	-	-	-	11.49	11.49
<b>Non-cash movements:</b>						
Unrealised foreign exchange	(0.93)	(15.66)	(4.72)	(3.12)	0.08	(24.35)
Others adjustment for lease	-	-	-	0.06	-	0.06
Derivative Gain (net)	-	-	-	-	2.58	2.58
<b>Net debt as at 30 June 2021*</b>	<b>645.77</b>	<b>(1,050.99)</b>	<b>(797.87)</b>	<b>(337.46)</b>	<b>(2.47)</b>	<b>(1,543.02)</b>

\*balances include interest accrued on borrowings

Particulars	Other assets		Liabilities from financing activities			Total
	Cash and cash equivalents	Non-current borrowings	Current borrowings	Lease Liabilities	Net Derivative Liabilities (Swap and Option)	
<b>Net debt as at 1 April 2020</b>	<b>368.63</b>	<b>(1,075.82)</b>	<b>(1,373.69)</b>	<b>(340.70)</b>	<b>(47.51)</b>	<b>(2,469.09)</b>
Cash flows	115.13	(43.10)	574.03	-	-	646.06
Acquisition of lease	-	-	-	(24.96)	-	(24.96)
Principal repayment of lease	-	-	-	77.32	-	77.32
Interest expense	-	(34.17)	(73.55)	(26.52)	-	(134.24)
Interest paid	-	34.78	75.93	26.52	-	137.23
Payment on Derivative Settlement (net)	-	-	-	-	44.56	44.56
<b>Non-cash movements:</b>						
Unrealised foreign exchange	(5.06)	34.78	(4.39)	(33.00)	(0.14)	(7.81)
Others adjustment for lease	-	-	-	2.64	-	2.64
Derivative Loss (net)	-	-	-	-	(13.53)	(13.53)
<b>Net debt as at 31 March 2021*</b>	<b>478.70</b>	<b>(1,083.53)</b>	<b>(801.67)</b>	<b>(318.70)</b>	<b>(16.62)</b>	<b>(1,741.82)</b>

\*balances include interest accrued on borrowings

Particulars	Other assets		Liabilities from financing activities			Total
	Cash and cash equivalents	Non-current borrowings	Current borrowings	Lease Liabilities	Net Derivative Liabilities (Swap and Option)	
<b>Net debt as at 31 March 2019</b>	<b>192.64</b>	<b>(847.59)</b>	<b>(1,288.92)</b>	<b>(308.19)</b>	<b>(11.74)</b>	<b>(2,263.80)</b>
Ind AS 116 transition adjustment	-	(0.74)	-	308.19	-	307.45
<b>Net debt as at 1 April 2019</b>	<b>192.64</b>	<b>(848.33)</b>	<b>(1,288.92)</b>	<b>-</b>	<b>(11.74)</b>	<b>(1,956.35)</b>
Cash flows	178.75	(133.41)	(45.48)	-	-	(0.14)
Recognised on adoption of IND AS 116	-	-	-	(244.74)	-	(244.74)
Acquisition of lease	-	-	-	(171.30)	-	(171.30)
Principal repayment of lease	-	-	-	53.56	-	53.56
Interest expense	-	(48.43)	(120.64)	(25.71)	-	(194.78)
Interest paid	-	47.27	121.24	25.71	-	194.22
Payment on Derivative Settlement (net)	-	-	-	-	23.14	23.14
<b>Non-cash movements:</b>						
Unrealised foreign exchange	(2.76)	(92.92)	(39.89)	21.26	-	(114.31)
Others adjustment for lease	-	-	-	0.52	-	0.52
Derivative Loss (net)	-	-	-	-	(58.91)	(58.91)
<b>Net debt as at 31 March 2020*</b>	<b>368.63</b>	<b>(1,075.82)</b>	<b>(1,373.69)</b>	<b>(340.70)</b>	<b>(47.51)</b>	<b>(2,469.09)</b>

\*balances include interest accrued on borrowings

Particulars	Other assets		Liabilities from financing activities			Total
	Cash and cash equivalents	Non-current borrowings	Current borrowings	Lease Liabilities	Net Derivative Liabilities (Swap and Option)	
<b>Net debt as at 1 April 2018</b>	<b>576.91</b>	<b>(1,247.58)</b>	<b>(1,498.28)</b>	<b>-</b>	<b>0.65</b>	<b>(2,168.30)</b>
Cash flows	(379.64)	450.27	206.81	-	-	277.44
Recognised on adoption of IND AS 116	-	-	-	(340.75)	-	(340.75)
Acquisition of lease	-	-	-	(14.94)	-	(14.94)
Principal repayment of lease	-	-	-	36.42	-	36.42
Interest expense	-	(63.86)	(132.16)	(29.23)	-	(225.25)
Interest paid	-	66.14	129.92	29.23	-	225.29
Payment on Derivative Settlement (net)	-	-	-	-	13.33	13.33
<b>Non-cash movements:</b>						
Unrealised foreign exchange	(4.63)	(52.56)	4.79	11.08	-	(41.32)
Derivative Loss (net)	-	-	-	-	(25.72)	(25.72)
<b>Net debt as at 31 March 2019*</b>	<b>192.64</b>	<b>(847.59)</b>	<b>(1,288.92)</b>	<b>(308.19)</b>	<b>(11.74)</b>	<b>(2,263.80)</b>

\*balances include interest accrued on borrowings

(All amounts in INR million, unless otherwise stated)

**Note: 42 Segment information**

The group is engaged in the business of designing, manufacturing and installation of process equipment and accessories and is primarily operated out of India. The group has identified its executive committee (which consist of Chairman, Managing Director & Chief Executive Officer, Head Product Management Group & Global Marketing, Head Global Operations, Head Global Finance (Chief Financial Officer), Head Human Resource and Company Secretary) as the chief operating decision maker ('CODM'). The CODM reviews the business as a single segment group.

**Other information**

(i) Revenue from external customers along with breakup between India and arising outside India.

Region	30 June 2021	31 March 2021	31 March 2020	31 March 2019
India	268.86	1,094.04	963.95	898.02
Outside India	1,463.21	6,961.18	5,884.52	5,439.55
<b>Total</b>	<b>1,732.07</b>	<b>8,055.22</b>	<b>6,848.47</b>	<b>6,337.57</b>

Revenue Outside India includes: Chile INR 248.02 Mn (31 March 2021: INR 1,611.44 Mn ; 31 March 2020: INR 1,328.55 Mn and 31 March 2019: INR 890.30 Mn), Australia INR 196.45 Mn (31 March 2021: INR 717.92 Mn ; 31 March 2020: INR 729.07 Mn and 31 March 2019: INR 984.96 Mn), South Africa INR 103.34 Mn (31 March 2021: INR 491.90 ; 31 March 2020: INR 373.92 Mn and 31 March 2019: INR 311.46 Mn) and Canada INR 219.06 Mn (31 March 2021: INR 513.08 Mn ; 31 March 2020: INR 504.45 Mn and 31 March 2019: INR 251.46 Mn)

(ii) Details of non-current assets (property, plant and equipment, right-of-use assets, capital work-in-progress, investment properties, intangible assets, intangible assets under development, goodwill on consolidation and other Non Current assets) based on geographical area is as below:

Region	30 June 2021	31 March 2021	31 March 2020	31 March 2019
India	1,447.96	1,454.94	1,380.92	1,452.28
Outside India	1,640.56	1,589.12	1,373.51	1,451.16
<b>Total</b>	<b>3,088.52</b>	<b>3,044.06</b>	<b>2,754.43</b>	<b>2,903.44</b>

Non-Current Assets Outside India includes: Chile INR 640.13 Mn (31 March 2021: INR 598.04 Mn ; 31 March 2020: INR 516.11 Mn and 31 March 2019: INR 495.05 Mn), Australia INR 652.91 Mn (31 March 2021: INR 649.89 Mn ; 31 March 2020: INR 552.84 Mn and 31 March 2019: INR 598.81 Mn), South Africa INR 293.97 Mn (31 March 2021: INR 286.35 Mn ; 31 March 2020: INR 268.29 Mn and 31 March 2019: INR 329.53 Mn) and Canada INR 19.46 Mn (31 March 2021: INR 18.53 Mn ; 31 March 2020: INR 10.54 Mn and 31 March 2019: INR 12.19 Mn)

Note: No Single customer represents 10% or more of the Group's total revenue during the period/ year ended 30 June 2021, 31 March 2021, 31 March 2020 and 31 March 2019.



**Note: 43 Interest in other entities**

**(a) Subsidiaries**

The group's subsidiaries as at 30 June 2021, 31 March 2021, 31 March 2020 and 31 March 2019 are set out below. Unless otherwise stated, they have share capital consisting solely of equity shares that are held directly by the group, and the proportion of ownership interests held equals the voting rights held by the group. The country of incorporation or registration is also their principal place of business.

Name of the entity	Place of business/ country of incorporation	Ownership interest held by the group				Ownership interest held by non-controlling interests			
		30 June 2021 %	31 March 2021 %	31 March 2020 %	31 March 2019 %	30 June 2021 %	31 March 2021 %	31 March 2020 %	31 March 2019 %
Tega Industries, Inc.	USA	100.00%	100.00%	100.00%	100.00%	0.00%	0.00%	0.00%	0.00%
Tega Industries Australia Pty. Ltd.	Australia	100.00%	100.00%	100.00%	100.00%	0.00%	0.00%	0.00%	0.00%
Tega Industries Canada Inc.	Canada	100.00%	100.00%	100.00%	100.00%	0.00%	0.00%	0.00%	0.00%
Tega Investments Limited	The Bahamas	100.00%	100.00%	100.00%	100.00%	0.00%	0.00%	0.00%	0.00%
Tega Investments South Africa Proprietary Limited	South Africa	100.00%	100.00%	100.00%	100.00%	0.00%	0.00%	0.00%	0.00%
Tega Industries Africa Proprietary Limited	South Africa	100.00%	100.00%	100.00%	100.00%	0.00%	0.00%	0.00%	0.00%
Tega Do Brasil Servicos Tecnicos Ltda	Brazil	99.99%	99.99%	99.99%	99.99%	0.01%	0.01%	0.01%	0.01%
Tega Holdings Pte Limited	Singapore	100.00%	100.00%	100.00%	100.00%	0.00%	0.00%	0.00%	0.00%
Tega Scanning Solutions Inc.#	Canada	0.00%	0.00%	0.00%	0.00%	0.00%	0.00%	0.00%	0.00%
Tega Holdings Pty Ltd	Australia	100.00%	100.00%	100.00%	100.00%	0.00%	0.00%	0.00%	0.00%
Losugen Pty Ltd	Australia	100.00%	100.00%	100.00%	100.00%	0.00%	0.00%	0.00%	0.00%
Tega Industries Chile SpA	Chile	100.00%	100.00%	100.00%	100.00%	0.00%	0.00%	0.00%	0.00%
Edoctum S.A.	Chile	100.00%	100.00%	100.00%	100.00%	0.00%	0.00%	0.00%	0.00%
Edoctum Peru S.A.C.	Peru	100.00%	100.00%	100.00%	100.00%	0.00%	0.00%	0.00%	0.00%

# Disposed off during the year ended 31 March 2019 w.e.f. 15 January 2019

**(b) Non-controlling interests (NCI)**

As noted from the above table, the non-controlling interests are not material to the group.

**(c) Transactions with Non-controlling interest (NCI)**

The Group has disposed off its entire shareholding in subsidiary Tega Scanning Solutions Inc. during the financial year 2018-19. Accordingly it has recognised the gain or loss associated with the loss of control attributable to the former controlling interest in the Restated Consolidated Statement of Profit and Loss.

**(d) Interests in joint venture**

Set out below are the details of the joint venture of the group as at 30 June 2021, 31 March 2021, 31 March 2020 and 31 March 2019. The entity listed below has share capital consisting solely of equity shares. The country of incorporation or registration is also their principal place of business, and the proportion of ownership interest is the same as the proportion of voting rights held.

Name of the entity	Place of business/ country of incorporation	Relationship	Accounting method	Carrying amount				Quoted fair value	% of ownership interest
				30 June 2021	31 March 2021	31 March 2020	31 March 2019		
Hosch Equipment (India) Limited	India	Joint Venture	Equity method	275.33	269.22	244.66	234.64	@	50%
<b>Total equity accounted investments</b>				<b>275.33</b>	<b>269.22</b>	<b>244.66</b>	<b>234.64</b>		

@ Unlisted equity, no quoted price available

**(i) Contingent liabilities in respect of joint venture**

Particulars	30 June 2021	31 March 2021	31 March 2020	31 March 2019
Contingent liabilities – joint venture	17.24	17.24	17.73	25.17
<b>Total Contingent liabilities</b>	<b>17.24</b>	<b>17.24</b>	<b>17.73</b>	<b>25.17</b>

**(ii) Summarised financial information for joint venture**

The tables below provide summarised financial information for that joint venture which is material to the group. The information disclosed reflects the amounts presented in the restated financial information of the relevant joint venture and not the Holding Company's share of those amounts.

**Summarised Restated Statement of Assets and Liabilities**

Particulars	Hosch Equipment (India) Limited			
	30 June 2021	31 March 2021	31 March 2020	31 March 2019
<i>Current assets</i>				
Cash and cash equivalents	19.27	6.29	5.60	0.06
Other assets	317.07	269.19	209.43	189.17
<b>Total current assets</b>	<b>336.34</b>	<b>275.48</b>	<b>215.03</b>	<b>189.23</b>
<b>Total non-current assets</b>	<b>19.50</b>	<b>74.86</b>	<b>80.49</b>	<b>78.08</b>
<i>Current liabilities</i>				
Financial liabilities	19.32	22.98	21.28	10.85
Other liabilities	12.01	15.74	12.01	11.62
<b>Total current liabilities</b>	<b>31.33</b>	<b>38.72</b>	<b>33.29</b>	<b>22.47</b>
<i>Non-current liabilities</i>				
Financial liabilities	2.81	3.07	4.83	4.10
Other liabilities	2.95	2.02	-	3.38
<b>Total non-current liabilities</b>	<b>5.76</b>	<b>5.09</b>	<b>4.83</b>	<b>7.48</b>
<b>Net assets</b>	<b>318.75</b>	<b>306.53</b>	<b>257.40</b>	<b>237.36</b>

Note- Hosch Equipment (India) Limited is having financial and technical collaboration with M/s Hosch (GB) Limited U.K., pioneers in the manufacture of Scrapers, having its registered office and manufacturing facilities at West Bengal, India.

Summarised restated statement of profit and loss

Particulars	Hosch Equipment (India) Limited			
	30 June 2021	31 March 2021	31 March 2020	31 March 2019
Revenue	44.98	202.76	163.56	170.33
Interest income	0.20	0.70	0.46	1.45
Depreciation and amortisation	0.72	3.52	3.65	2.96
Finance costs	0.12	0.93	0.93	0.70
Income tax expense	4.10	17.90	17.38	13.36
<b>Restated profit from continuing operations</b>	<b>12.32</b>	<b>53.56</b>	<b>36.17</b>	<b>36.19</b>
Restated other comprehensive income/ (loss)	(0.10)	0.07	(0.04)	(1.51)
<b>Restated total comprehensive income</b>	<b>12.22</b>	<b>53.63</b>	<b>36.13</b>	<b>34.68</b>
<b>Dividends paid to Holding Company</b>	<b>-</b>	<b>2.25</b>	<b>8.14</b>	<b>2.71</b>

Reconciliation to carrying amounts

Particulars	Hosch Equipment (India) Limited			
	30 June 2021	31 March 2021	31 March 2020	31 March 2019
<b>Opening net assets</b>	<b>306.53</b>	<b>257.40</b>	<b>237.36</b>	<b>208.11</b>
Ind AS 116 transition adjustment	-	-	0.18	-
<b>Opening net assets</b>	<b>306.53</b>	<b>257.40</b>	<b>237.54</b>	<b>208.11</b>
Restated profit for the period/ year	12.32	53.56	36.17	36.19
Restated other comprehensive income/ (loss)	(0.10)	0.07	(0.04)	(1.51)
Dividends paid including tax	-	(4.50)	(16.27)	(5.43)
<b>Closing net assets</b>	<b>318.75</b>	<b>306.53</b>	<b>257.40</b>	<b>237.36</b>
Group's share in %	50%	50%	50%	50%
Group's share in INR	159.37	153.26	128.70	118.68
Goodwill	115.96	115.96	115.96	115.96
<b>Carrying amount</b>	<b>275.33</b>	<b>269.22</b>	<b>244.66</b>	<b>234.64</b>

(iii) Share of restated profit

Particulars	30 June 2021	31 March 2021	31 March 2020	31 March 2019
Share of restated profits from joint venture	6.16	26.78	18.09	18.09
<b>Total share of restated profits from joint venture</b>	<b>6.16</b>	<b>26.78</b>	<b>18.09</b>	<b>18.09</b>

(iv) Share of restated other comprehensive income/ (loss)

Particulars	30 June 2021	31 March 2021	31 March 2020	31 March 2019
Share of restated other comprehensive income/ (loss) from joint venture	(0.05)	0.03	(0.02)	(0.75)
<b>Total share of restated other comprehensive income/ (loss) from joint venture</b>	<b>(0.05)</b>	<b>0.03</b>	<b>(0.02)</b>	<b>(0.75)</b>

**Note: 44 A Contingent liabilities (to the extent not provided for)**

Particulars	30 June 2021	31 March 2021	31 March 2020	31 March 2019
<b>(i) Contingent liabilities - Claims against the company not acknowledged as debt</b>				
Disputed Excise Duty	14.75	14.75	14.75	25.37
Disputed Service Tax	3.08	3.08	3.08	6.17
Disputed Income Tax	64.54	64.54	10.45	85.18
Disputed Sales Tax	6.56	6.56	13.89	26.82
Disputed ESI Dues	-	-	-	0.31
<b>(ii) Other money for which the Group is contingently liable</b>				
(1) Pending finalisation of legal/ arbitration proceedings, the extent of eventual liability, against a customer's claims (not admitted by the Company) for alleged unsatisfactory product performance as may arise, is currently not ascertainable and no provision in this regard has been considered necessary by the Management.	4.05	4.05	4.05	19.74
(2) The Company stands as surety in connection with General Bond executed by MM Aqua Technologies Limited for the due dispatch of excisable goods for export without payment of duty	1.50	1.50	1.50	1.50

In respect of the contingent liabilities mentioned in (i) above, pending resolution of the respective proceedings, it is not practicable for the Group to estimate the timings of cash outflows, if any.

**Note: 44 B Commitments**

Particulars	30 June 2021	31 March 2021	31 March 2020	31 March 2019
<b>(i)</b> Estimated amount of contracts remaining to be executed on capital account and not provided for	52.90	56.40	11.20	67.41

**Note: 44 C** The Holding Company and its Joint Venture has evaluated the impact of the Supreme Court Judgment in case of "Vivekananda Vidyamandir And Others Vs. The Regional Provident Fund Commissioner (II) West Bengal" and the related circular (Circular No. C-1/1(33)2019/Vivekananda Vidya Mandir/284) dated 20 March 2019 issued by the Employees' Provident Fund Organisation in relation to non-exclusion of certain allowances from the definition of "basic wages" of the relevant employees for the purposes of determining contribution to provident fund under the Employees' Provident Funds & Miscellaneous Provisions Act, 1952. While further clarification on applicability and operation of the Order is awaited from the Provident Fund authorities, based on estimates by the management, the impact of the Order is not expected to be material on the Restated Consolidated Financial Information. The management will continue to assess the impact of further developments relating to retrospective application of the Supreme Court's judgement considering the additional guidance as and when issued by the statutory authorities.

Note: 45 Earnings per share

	Particulars	30 June 2021	31 March 2021	31 March 2020	31 March 2019
	<b>Computation of Earnings for Equity Shares</b>				
A	Restated Net Profit attributable to the shareholders of the company	118.82	1,364.05	655.04	326.28
B	Less: Preference share dividend and tax thereon	-	0.00 <sup>^</sup>	0.00 <sup>^</sup>	0.00 <sup>^</sup>
C = A-B	Restated Profit attributable to equity shareholders	118.82	1,364.05	655.04	326.28
D	Weighted average number of equity shares outstanding during the period/ year other than which are dilutive	56,601,259	56,601,259	56,601,259	56,601,259
E	Effect of equity shares which are dilutive	999,609	999,609	999,609	999,609
F	Effect of compulsorily convertible participatory preference shares which are dilutive	8,692,281	8,692,281	8,692,281	8,692,281
G	Effect of potential Ordinary shares on Employee Stock Options outstanding	303,188	300,894	269,154	277,631
H = (D+E+F+G)	Weighted average number of equity shares outstanding during the period/ year (dilutive)	66,596,337	66,594,043	66,562,303	66,570,780
	<b>Restated Earnings per equity share</b> (Face Value INR 10/- per share)				
C/D	Restated Earnings per share - Basic (INR)	2.10	24.10	11.57	5.76
A/H	Restated Earnings per share - Diluted (INR)	1.78	20.48	9.84	4.90

<sup>^</sup>Amount is below the rounding off norm adopted by the Group

**Note: 46 Related party transactions**

**Related party disclosure pursuant to Ind AS 24 prescribed under the act**

**Details of related parties:**

<b>Description of relationship</b>	<b>Names of related parties</b>
<b>Ultimate Holding Company</b>	Nihal Fiscal Services Private Limited
<b>Subsidiaries</b>	Tega Industries, Inc. Tega Industries Australia Pty. Ltd. Tega Industries Canada Inc. Tega Investments Limited Tega Do Brasil Servicos Tecnicos Ltda Tega Holdings Pte Limited
<b>Subsidiaries of Subsidiary</b>	Tega Investments South Africa Proprietary Limited Tega Industries Africa Proprietary Limited Tega Scanning Solutions Inc.# Tega Holdings Pty Ltd Losugen Pty Ltd Tega Industries Chile SpA Edoctum S.A. Edoctum Peru S.A.C.
<b>Fellow Subsidiaries</b>	Maple Orgtech (India) Limited MM Aqua Technologies Limited
<b>Joint Venture</b>	Hosch Equipment (India) Limited
<b>Key Management Personnel (KMP)</b>	Madan Mohan Mohanka - Chairman and Wholetime Director Mehul Mohanka - Managing Director Syed Yaver Imam - Executive Director (Director from 1 June 2019 to 31 March 2021, Wholetime Director upto 31 May 2019) Manju Mohanka - Director Jahar Saha - Director (upto 8 October 2020) Hemant Madhusudan Nerurkar - Director Rudolph Michael Edge - Director Dhiraj Poddar - Director Jagdishwar Prasad Sinha - Director (from 1 May 2021) Madhu Dubhashi - Director (from 1 May 2021) Manoj Kumar Agarwal - Chief Financial Officer Rakhi Sarkar - Company Secretary (upto 31 August 2018) Sudipta Bhowal - Company Secretary (from 1 September 2018)
<b>Relatives of KMP</b>	Manish Mohanka
<b>Post Employment Benefit Plan</b>	Tega India Ltd Employees Gratuity Fund Tega India & Associate Companies Super Annuation Fund Tega India Ltd Staff Provident Fund Tega Industries (SEZ) Ltd Super Annuation Fund Tega Industries (SEZ) Ltd Gratuity Trust
<b>Entities in which KMP/ Relatives of KMP can exercise significant influence</b>	TPW Engineering Limited Marudhar Food and Credit Limited Madan & Manju Mohanka Foundation

Note: Related parties have been identified by the Management.

# Disposed off during the year ended 31 March 2019 w.e.f. 15 January 2019

**a) The following is the summary of the transactions with related parties for the period/ year ended 30 June 2021, 31 March 2021, 31 March 2020 and 31 March 2019:**

<b>Particulars</b>	<b>30 June 2021</b>	<b>31 March 2021</b>	<b>31 March 2020</b>	<b>31 March 2019</b>
<b>Sale of Goods and Services</b>				
Hosch Equipment (India) Limited	2.93	12.56	9.04	5.93
MM Aqua Technologies Limited	0.04	-	3.01	0.49
<b>Purchase of Goods and services</b>				
Hosch Equipment (India) Limited	-	0.96	0.83	0.17
Maple Orgtech (India) Limited	-	0.10	-	0.04
<b>Re-imbusement of Expenses</b>				
Hosch Equipment (India) Limited	0.11	0.10	0.19	0.02
TPW Engineering Limited	-	0.05	-	-
Maple Orgtech (India) Limited	0.08	0.04	-	-
<b>Recovery of Expenses</b>				
Hosch Equipment (India) Limited	-	0.21	0.08	0.01
MM Aqua Technologies Limited	-	0.02	-	0.21
<b>Sales Commission Earned</b>				
Hosch Equipment (India) Limited	3.11	15.29	12.79	13.18
<b>Rent/ Service Charges/ Hire Charges</b>				
TPW Engineering Limited	6.77	25.80	24.17	22.89
Maple Orgtech (India) Limited	0.09	0.38	0.39	0.42
Mr Manish Mohanka	0.39	1.50	1.43	1.36
Mrs Manju Mohanka	0.04	0.13	0.13	0.12
<b>Dividend Received</b>				
Hosch Equipment (India) Limited	-	2.25	6.75	2.25
<b>Contribution to post employment benefit plan</b>				
Tega India Ltd Employees Gratuity Fund	-	-	30.00	11.00
Tega Industries (SEZ) Ltd Gratuity Trust	-	0.03	-	0.00 <sup>^</sup>
Tega India & Associate Companies Super Annuation Fund	1.73	6.36	6.55	6.50
Tega Industries (SEZ) Ltd Super Annuation Fund	0.16	0.59	0.50	0.39
<b>Business Support Service Expense</b>				
MM Aqua Technologies Limited	0.47	1.86	-	-
<b>Business Support Service Income</b>				
Hosch Equipment (India) Limited	2.29	9.30	9.39	9.34
Maple Orgtech (India) Limited	0.08	0.30	0.34	0.30
MM Aqua Technologies Limited	0.30	0.78	0.09	0.09
<b>Payment made for transfer of lease</b>				
TPW Engineering Limited	-	201.33	-	-
<b>Loans and advances given/(Recovered) (Net)</b>				
TPW Engineering Limited	-	0.61	0.22	-

<sup>^</sup> Amount is below the rounding off norm adopted by the Group

#### **Remuneration to KMP**

During the period/ year, the Group has recognised an amount of INR 32.02 Mn (31 March 2021: INR 115.23 Mn , 31 March 2020: INR 120.51 Mn and 31 March 2019: INR 80.25 Mn) as remuneration paid/ payable to key managerial personnel. The details of such remunerations are as below:

<b>Particulars</b>	<b>30 June 2021</b>	<b>31 March 2021</b>	<b>31 March 2020</b>	<b>31 March 2019</b>
Short term employee benefits	25.11	90.17	89.84	76.41
Post employment benefits	1.18	3.54	8.78	1.21
Other long term employee benefits	0.05	0.10	3.72	0.44
<b>Total employee benefits expense</b>	<b>26.34</b>	<b>93.81</b>	<b>102.34</b>	<b>78.06</b>
Perquisites	0.42	1.36	0.33	-
Sitting fees	0.06	0.34	0.32	0.14
Commission/ Incentive to Director's	1.97	7.88	8.30	2.05
Professional Fees	3.23	11.84	9.22	-
<b>Total other expenses</b>	<b>5.68</b>	<b>21.42</b>	<b>18.17</b>	<b>2.19</b>

Note : Refer note 43(d) for details of share of profit of the period/ year ended 30 June 2021, 31 March 2021, 31 March 2020 and 31 March 2019 and investment outstanding as at 30 June 2021, 31 March 2021, 31 March 2020 and 31 March 2019 relating to Joint Venture.

**b) The following is the summary of balance outstanding with related parties for the period/ year ended 30 June 2021, 31 March 2021, 31 March 2020 and 31 March 2019:**

<b>Particulars</b>	<b>30 June 2021</b>	<b>31 March 2021</b>	<b>31 March 2020</b>	<b>31 March 2019</b>
<u>Trade Receivables</u>				
Hosch Equipment (India) Limited	1.82	4.90	4.02	2.30
Maple Orgtech (India) Limited	0.25	0.17	1.12	0.75
MM Aqua Technologies Limited	4.49	4.14	6.82	3.17
<u>Advances/ Deposit /Other Receivables</u>				
TPW Engineering Limited	3.38	3.38	2.77	2.99
Mr Madan Mohan Mohanka	3.72	-	-	-
Mr Manish Mohanka	0.93	0.19	0.19	0.19
Mrs Manju Mohanka	0.05	0.05	0.05	0.05
<u>Trade Payables</u>				
TPW Engineering Limited	0.09	0.09	0.09	0.00 <sup>^</sup>
Maple Orgtech (India) Limited	0.54	0.37	1.38	1.00
MM Aqua Technologies Limited	3.05	2.57	0.43	0.43
Mr Manish Mohanka	0.28	-	-	-
<u>Financial Liabilities</u>				
Hosch Equipment (India) Limited	0.93	0.93	0.93	0.93
<u>Other current liabilities</u>				
Tega India & Associate Companies Super Annuation Fund	2.01	1.73	1.64	1.58
Tega Industries (SEZ) Ltd Super Annuation Fund	0.18	0.16	0.13	0.12
<u>Provisions</u>				
Tega India Ltd Employees Gratuity Fund	23.26	19.94	16.11	31.61
Tega Industries (SEZ) Ltd Gratuity Trust	4.96	4.23	3.10	2.42

<sup>^</sup> Amount is below the rounding off norm adopted by the Group



**c) The following are the details of the transactions eliminated during the period/ year ended 30 June 2021, 31 March 2021, 31 March 2020 and 31 March 2019:**

**(i) Tega Industries Limited**

<b>Particulars</b>	<b>30 June 2021</b>	<b>31 March 2021</b>	<b>31 March 2020</b>	<b>31 March 2019</b>
<u>Sale of Goods and Services</u>				
Tega Industries, Inc.	42.90	372.48	166.13	-
Tega Industries Australia Pty. Ltd.	8.78	-	2.85	-
Tega Industries Canada Inc.	125.69	393.11	318.00	-
Tega Holdings Pte Limited	70.38	361.33	816.31	961.56
Tega Industries Africa Proprietary Limited	87.18	247.42	168.53	222.40
Losugen Pty Ltd	27.34	86.87	109.39	156.92
Tega Industries Chile SpA	37.98	103.10	120.39	202.43
Tega Do Brasil Servicos Tecnicos Ltda	-	0.28	0.22	1.50
<u>Purchase of Goods and services</u>				
Tega Industries Africa Proprietary Limited	-	0.27	-	20.67
Tega Industries Chile SpA	-	3.97	17.76	3.66
Tega Scanning Solutions Inc. ( Upto 15 January 2019)	-	-	-	2.13
<u>Re-imbusement of Expenses</u>				
Tega Industries, Inc.	-	-	12.96	18.96
Tega Industries Australia Pty. Ltd.	-	-	-	8.81
Tega Industries Canada Inc.	-	-	-	3.91
Tega Industries Africa Proprietary Limited	-	7.20	-	-
Tega Holdings Pte Limited	14.46	-	4.35	0.25
Tega Do Brasil Servicos Tecnicos Ltda	-	1.58	7.25	-
Tega Industries Chile SpA	0.13	3.29	2.30	-
Losugen Pty Ltd	1.51	-	-	-
<u>Recovery of Expenses</u>				
Tega Industries, Inc.	-	-	0.04	-
Tega Industries Australia Pty. Ltd.	-	0.22	0.00 <sup>^</sup>	0.03
Tega Industries Canada Inc.	0.72	27.88	4.50	-
Tega Industries Africa Proprietary Limited	0.70	1.06	2.42	-
Tega Holdings Pte Limited	0.98	0.92	2.69	4.91
Tega Industries Chile SpA	0.70	4.47	0.10	1.92
Losugen Pty Ltd	-	0.41	0.14	0.09
Tega Do Brasil Servicos Tecnicos Ltda	-	-	0.34	-
<u>Marketing Fee (Expense)</u>				
Tega Do Brasil Servicos Tecnicos Ltda	8.93	26.01	31.80	36.71
Tega Holdings Pte Limited	28.93	50.15	35.61	33.00
<u>Marketing Fee (Income)</u>				
Tega Industries Africa Proprietary Limited	-	-	-	2.30
Tega Industries Chile SpA	-	3.09	2.95	19.09
<u>Business Support Service Income</u>				
Tega Industries Africa Proprietary Limited	3.66	11.23	11.37	13.63
Tega Industries Canada Inc.	0.00 <sup>^</sup>	0.08	0.07	-
Losugen Pty Ltd	0.16	0.98	1.27	1.75
Tega Industries Chile SpA	3.92	19.01	15.66	12.25
Tega Holdings Pte Limited	0.19	1.77	1.79	3.64
Tega Industries, Inc.	0.00	0.09	0.09	-
Tega Industries Australia Pty. Ltd.	0.05	0.16	0.12	-
<u>Sale of property, plant and equipment</u>				
Tega Industries Chile SpA	-	-	2.12	10.44
<u>Purchase of property, plant and equipment</u>				
Tega Industries Chile SpA	-	-	7.56	-
Tega Industries Africa Proprietary Limited	-	-	7.02	-
<u>Investments in subsidiaries</u>				
Tega Holdings Pte Limited	-	-	586.78	575.88

<sup>^</sup> Amount is below the rounding off norm adopted by the Group

**(ii) Tega Investments Limited**

<b>Particulars</b>	<b>30 June 2021</b>	<b>31 March 2021</b>	<b>31 March 2020</b>	<b>31 March 2019</b>
<u>Repayment of loan given</u>				
Tega Industries Africa Proprietary Limited	-	120.35	-	-
Tega Industries Chile SpA	-	-	-	3.50
<u>Interest Income</u>				
Tega Industries Africa Proprietary Limited	-	0.65	3.75	3.69
Tega Industries Chile SpA	-	-	-	0.14

**(iii) Tega Do Brasil Servicos Tecnicos Ltda**

Particulars	30 June 2021	31 March 2021	31 March 2020	31 March 2019
<u>Purchase of Goods and services</u>				
Tega Industries Chile SpA	-	-	-	2.88
<u>Re-imbusement of Expenses</u>				
Tega Industries Chile SpA	-	0.83	0.35	-
Tega Industries Canada Inc.	-	-	0.93	-
<u>Recovery of Expenses</u>				
Tega Industries Chile SpA	-	-	-	0.43

**(iv) Tega Industries Australia Pty. Ltd.**

Particulars	30 June 2021	31 March 2021	31 March 2020	31 March 2019
<u>Purchase of Goods and services</u>				
Losugen Pty Ltd	1.00	1.37	1.71	-
Tega Industries Chile SpA	-	-	0.12	-
<u>Professional fees</u>				
Losugen Pty Ltd	-	8.24	6.77	2.88
<u>Re-imbusement of Expenses</u>				
Losugen Pty Ltd	3.89	1.68	-	2.43
<u>Sale of property, plant and equipment</u>				
Tega Industries Africa Proprietary Limited	-	-	-	1.30

**(v) Tega Industries, Inc.**

Particulars	30 June 2021	31 March 2021	31 March 2020	31 March 2019
<u>Purchase of Goods and services</u>				
Tega Industries Chile SpA	-	0.14	2.32	-
Tega Scanning Solutions Inc. ( Upto 15 January 2019)	-	-	-	0.58
<u>Re-imbusement of Expenses</u>				
Tega Industries Canada Inc.	-	-	1.81	1.90
Tega Industries Chile SpA	-	0.21	-	-

**(vi) Tega Industries Chile SpA**

Particulars	30 June 2021	31 March 2021	31 March 2020	31 March 2019
<u>Purchase of Goods and services</u>				
Tega Industries Africa Proprietary Limited	-	-	-	3.91
<u>Sale of Goods and Services</u>				
Edoctum S.A.	-	1.23	1.50	1.68
Tega Industries Africa Proprietary Limited	-	-	-	1.37
<u>Re-imbusement of Expenses</u>				
Edoctum Peru S.A.C.	-	-	-	0.40
<u>Recovery of Expenses</u>				
Edoctum S.A.	0.58	4.50	8.31	3.04
Edoctum Peru S.A.C.	1.13	-	1.26	-

**(vii) Tega Industries Africa Proprietary Limited**

Particulars	30 June 2021	31 March 2021	31 March 2020	31 March 2019
<u>Purchase of Goods and services</u>				
Tega Scanning Solutions Inc. (Upto 15 January 2019)	-	-	-	0.49
<u>Dividend Paid</u>				
Tega Investments South Africa Proprietary Limited	0.78	-	-	-

**(viii) Tega Holdings Pte Limited**

Particulars	30 June 2021	31 March 2021	31 March 2020	31 March 2019
<u>Purchase of Goods and services</u>				
Tega Industries Chile SpA	-	-	-	3.82
<u>Sale of Goods and Services</u>				
Tega Industries Canada Inc.	-	0.18	104.92	210.54
Tega Industries Australia Pty. Ltd.	61.90	304.42	358.28	394.28
Tega Industries, Inc.	-	-	130.77	258.35
<u>Re-imbusement of Expenses</u>				
Edoctum Peru S.A.C.	-	-	1.14	-
Tega Industries Chile SpA	-	-	1.67	-
<u>Recovery of Expenses</u>				
Edoctum Peru S.A.C.	-	2.91	-	-
Tega Industries Chile SpA	-	4.80	-	-
Tega Investments Limited	2.23	-	-	-
<u>Business Support Service (Income)</u>				
Tega Industries Australia Pty. Ltd.	0.41	10.16	14.95	15.24
Tega Industries Africa Proprietary Limited	0.96	2.77	2.81	3.06
<u>Loans given</u>				
Tega Industries Africa Proprietary Limited	-	156.06	-	-
Tega Industries Chile SpA	-	-	-	126.68
<u>Interest Income</u>				
Tega Holdings Pty Ltd	8.40	31.87	29.03	34.71
Tega Industries Chile SpA	2.74	12.15	17.86	20.58
Tega Investments Limited	-	1.23	8.35	11.81
Tega Industries Africa Proprietary Limited	0.96	3.36	-	-
<u>Investments in subsidiaries</u>				
Tega Industries Chile SpA	-	-	-	57.58
Tega Investments South Africa Proprietary Limited	-	99.44	-	-
<u>Interest expenses</u>				
Tega Investments Limited	0.12	0.45	-	-
<u>Loan taken</u>				
Tega Investments Limited	-	26.10	-	-
<u>Repayment of Loan Given</u>				
Tega Investments Limited	-	155.73	-	-
Tega Holdings Pty Ltd	-	-	26.44	38.99
Tega Do Brasil Servicos Tecnicos Ltda	-	-	-	6.28
Tega Industries Africa Proprietary Limited	29.63	-	-	-
<u>Conversion of Loan into Investment</u>				
Tega Industries Chile SpA	-	-	-	1,930.14

**(ix) Tega Industries Canada Inc.**

Particulars	30 June 2021	31 March 2021	31 March 2020	31 March 2019
<u>Purchase of Goods and services</u>				
Tega Industries Chile SpA	-	-	1.33	-
Tega Scanning Solutions Inc. (Upto 15 January 2019)	-	-	-	0.28
<u>Recovery of expenses</u>				
Tega Scanning Solutions Inc. (Upto 15 January 2019)	-	-	-	0.01

**(x) Tega Holdings Pty Ltd**

Particulars	30 June 2021	31 March 2021	31 March 2020	31 March 2019
<u>Dividend Income</u>				
Losugen Pty Ltd	-	-	28.87	61.05
<u>Interest Income</u>				
Losugen Pty Ltd	-	0.44	1.56	2.09
<u>Loans and advances given (Tax Benefit)</u>				
Losugen Pty Ltd	-	3.52	8.44	29.82
<u>Loan repayment Received</u>				
Losugen Pty Ltd	3.39	-	-	-

**(xi) Edoctum S.A.**

Particulars	30 June 2021	31 March 2021	31 March 2020	31 March 2019
<u>Recovery of Expenses</u>				
Edoctum Peru S.A.C.	-	-	3.47	-

d) The following are the details of the balances eliminated during the period/ year ended 30 June 2021, 31 March 2021, 31 March 2020 and 31 March 2019:

(i) Tega Industries Limited

Particulars	30 June 2021	31 March 2021	31 March 2020	31 March 2019
<u>Trade Receivables</u>				
Losugen Pty Ltd	27.14	27.01	31.99	41.70
Tega Industries Africa Proprietary Limited	120.14	61.80	33.24	99.23
Tega Holdings Pte Limited	170.14	312.58	342.42	592.99
Tega Industries Australia Pty. Ltd.	8.90	0.16	2.88	0.03
Tega Industries Canada Inc.	186.75	153.15	203.58	0.10
Tega Industries, Inc.	0.00 <sup>^</sup>	40.16	42.57	-
Tega Industries Chile SpA	140.45	96.50	417.25	398.11
<u>Trade Payables</u>				
Tega Industries Chile SpA	11.16	11.81	21.92	3.56
Tega Do Brasil Servicos Tecnicos Ltda	5.20	-	-	0.76
Tega Industries, Inc.	-	-	13.75	24.17
Tega Industries Canada Inc.	-	-	-	0.71
Tega Industries Africa Proprietary Limited	6.82	6.97	-	14.27
Tega Holdings Pte Limited	94.44	50.16	35.61	36.24
Losugen Pty Ltd	1.51	-	-	-
<u>Loans and Advances-Taken</u>				
Tega Industries, Inc.	4.65	-	-	-
<u>Standby Letter of credit</u>				
Tega Industries Chile SpA				
- Limit USD 3.55 Mn (31 March 2021: USD 3.55 Mn ; 31 March 2020: USD 2.00 Mn and 31 March 2019: USD 2.00 Mn)	263.50	259.17	151.33	138.31
- Utilisation USD 3.21 Mn (31 March 2021: USD 3.31 Mn ; 31 March 2020: USD 1.90 Mn and 31 March 2019: USD 1.90 Mn)	238.79	241.72	143.76	131.39
Tega Holdings Pte Limited				
- Limit USD NIL (31 March 2021: USD NIL ; 31 March 2020: USD NIL and 31 March 2019: USD 8.76 Mn)	-	-	-	605.52
- Utilisation USD NIL (31 March 2021: USD NIL ; 31 March 2020: USD NIL and 31 March 2019: USD 6.73 Mn)	-	-	-	465.68

<sup>^</sup> Amount is below the rounding off norm adopted by the Group

(ii) Tega Investments Limited

Particulars	30 June 2021	31 March 2021	31 March 2020	31 March 2019
<u>Loans and advances</u>				
Tega Industries Africa Proprietary Limited	-	-	122.90	112.32
<u>Interest Receivable</u>				
Tega Industries Africa Proprietary Limited	-	-	29.89	23.67

(iii) Tega Do Brasil Servicos Tecnicos Ltda

Particulars	30 June 2021	31 March 2021	31 March 2020	31 March 2019
<u>Trade payables</u>				
Tega Industries Chile SpA	1.19	1.17	0.31	4.44

(iv) Tega Industries Australia Pty. Ltd.

Particulars	30 June 2021	31 March 2021	31 March 2020	31 March 2019
<u>Trade payables</u>				
Losugen Pty Ltd	2.47	1.17	2.53	0.74
Tega Industries Chile SpA	-	-	0.13	-

(v) Tega Industries, Inc.

Particulars	30 June 2021	31 March 2021	31 March 2020	31 March 2019
<u>Trade Payables</u>				
Tega Industries Chile SpA	-	0.14	-	-
Tega Industries Canada Inc.	-	-	0.31	0.39

(vi) Tega Industries Chile SpA

Particulars	30 June 2021	31 March 2021	31 March 2020	31 March 2019
<u>Trade Receivables</u>				
Edoctum S.A.	37.41	36.46	27.18	20.53
Edoctum Peru S.A.C.	1.13	-	-	0.39
<u>Trade Payables</u>				
Edoctum Peru S.A.C.	-	0.81	0.85	-

**(vii) Tega Holdings Pte Limited**

Particulars	30 June 2021	31 March 2021	31 March 2020	31 March 2019
<u>Trade Receivables</u>				
Tega Industries Canada Inc.	-	0.19	0.69	101.60
Edoctum Peru S.A.C.	-	3.58	0.47	-
Tega Industries Africa Proprietary Limited	3.78	2.77	2.88	3.03
Tega Industries Australia Pty. Ltd.	75.10	205.65	165.91	127.59
Tega Industries, Inc.	-	-	-	19.05
Tega Industries Chile SpA	-	-	2.71	0.97
<u>Trade Payables</u>				
Tega Industries Chile SpA	7.04	-	-	-
Edoctum Peru S.A.C.	8.91	6.47	8.89	8.37
Edoctum S.A.	0.65	2.15	0.90	0.61
<u>Loans and advances</u>				
Tega Holdings Pty Ltd	399.81	397.95	329.25	376.89
Tega Industries Chile SpA	342.40	333.52	344.66	315.00
Tega Industries Africa Proprietary Limited	120.79	148.49	-	-
Tega Investments Limited	-	-	163.82	149.72
Edoctum Peru S.A.C.	0.45	-	-	-
<u>Interest Receivable</u>				
Tega Holdings Pty Ltd	43.48	35.85	17.90	2.40
Tega Industries Chile SpA	77.55	73.65	63.71	41.48
Tega Industries Africa Proprietary Limited	4.36	3.34	-	-
Tega Investments Limited	-	-	70.02	56.16
<u>Borrowings</u>				
Tega Investments Limited	13.73	15.86	-	-
<u>Interest accrued on borrowings</u>				
Tega Investments Limited	0.57	0.33	-	-

**(viii) Tega Industries Canada Inc.**

Particulars	30 June 2021	31 March 2021	31 March 2020	31 March 2019
<u>Trade Payables</u>				
Tega Industries Chile SpA	-	-	1.41	-
<u>Trade Receivables</u>				
Tega Industries, Inc.	-	-	0.29	0.38

**(ix) Tega Holdings Pty Ltd**

Particulars	30 June 2021	31 March 2021	31 March 2020	31 March 2019
<u>Loans and advances (Including Interest)</u>				
Losugen Pty Ltd	14.25	17.58	20.26	41.64

**(x) Edoctum S.A.**

Particulars	30 June 2021	31 March 2021	31 March 2020	31 March 2019
<u>Trade Receivables</u>				
Edoctum Peru S.A.C.	6.60	6.41	6.70	3.93

e) The following are the details of the investment eliminated during the period/ year ended 30 June 2021, 31 March 2021, 31 March 2020 and 31 March 2019:

(i) Tega Industries Limited

Particulars	30 June 2021	31 March 2021	31 March 2020	31 March 2019
<b>Investment in Equity</b>				
Tega Investments Limited	2.32	2.32	2.32	2.32
Tega Holdings Pte Limited	0.43	0.43	0.43	0.43
Tega Do Brasil Servicos Tecnicos Ltda	10.17	10.17	10.17	10.17
Tega Industries Canada Inc.	1.96	1.96	1.96	1.96
Tega Industries Australia Pty. Ltd.	2.31	2.31	2.31	2.31
Tega Industries, Inc.	9.52	9.52	9.52	9.52
<b>Investment in Preference Shares</b>				
Tega Holdings Pte Limited	3,464.32	3,464.32	3,464.32	2,877.54
<b>Provision for diminution in the value of equity</b>				
Tega Do Brasil Servicos Tecnicos Ltda	9.60	9.60	-	-
<b>Fair value (gain)/ loss in the value of preference shares</b>				
Tega Holdings Pte Limited	(960.17)	(887.56)	1,000.84	1,157.07

(ii) Tega Investments Limited

Particulars	30 June 2021	31 March 2021	31 March 2020	31 March 2019
<b>Investment in Equity</b>				
Tega Investments South Africa Proprietary Limited	-	-	22.70	20.75

(iii) Tega Holdings Pte Limited

Particulars	30 June 2021	31 March 2021	31 March 2020	31 March 2019
<b>Investment in Equity</b>				
Tega Holdings Pty Ltd	194.36	190.96	186.31	179.32
Tega Industries Chile SpA	632.27	621.21	606.07	583.35
Tega Investments South Africa Proprietary Limited	101.21	99.44	-	-
Edoctum S.A.	0.01	0.01	0.01	0.01
<b>Investment in Preference Shares</b>				
Tega Industries Chile SpA	2,074.22	2,037.94	1,988.26	1,913.73
<b>Provision for diminution in the value of equity</b>				
Tega Industries Chile SpA	105.97	104.11	101.57	97.77
<b>Fair value (gain)/ loss in the value of preference shares</b>				
Tega Industries Chile SpA	422.12	315.82	1,644.88	1,879.60

(iv) Tega Investments South Africa Proprietary Limited

Particulars	30 June 2021	31 March 2021	31 March 2020	31 March 2019
<b>Investment in Equity</b>				
Tega Industries Africa Proprietary Limited	48.45	45.98	39.44	44.44

(v) Tega Holdings Pty Ltd

Particulars	30 June 2021	31 March 2021	31 March 2020	31 March 2019
<b>Investment in Equity</b>				
Losugen Pty Ltd	774.04	773.10	639.48	680.35

(vi) Tega Industries Chile SpA

Particulars	30 June 2021	31 March 2021	31 March 2020	31 March 2019
<b>Investment in Equity</b>				
Edoctum S.A.	0.55	0.54	0.48	0.55

(vii) Edoctum S.A.

Particulars	30 June 2021	31 March 2021	31 March 2020	31 March 2019
<b>Investment in Equity</b>				
Edoctum Peru S.A.C.	0.02	0.02	0.02	0.02

**Note:47 Share-based payments**

(a) The share-based payment plan is an employee option plan. The options are equity settled options.

**(b) Set out below is the summary of options**

Particulars	30 June 2021		31 March 2021		31 March 2020		31 March 2019	
	Average exercise price/ share in INR	No. of options	Average exercise price/ share in INR	No. of options	Average exercise price/ share in INR	No. of options	Average exercise price/ share in INR	No. of options
Opening balance	38.91	357,251	38.91	357,251	38.91	361,933	36.75	361,933
Granted during the period/ year	-	-	-	-	-	-	-	-
Exercised during the period/ year	-	-	-	-	-	-	-	-
Expired during the period/ year	-	-	-	-	-	4,682	-	-
Closing balance		357,251		357,251		357,251		361,933
Vested and exercisable		357,251		357,251		357,251		354,134

**(c) Share options outstanding at the end of the period/ year have the following exercise period and exercise prices:**

Grant	Grant Date	Exercise period	Exercise Price/ Share in INR	Share Options as on 30 June 2021	Share Options as on 31 March 2021	Share Options as on 31 March 2020	Share Options as on 31 March 2019
Grant I	04-Mar-11	2 years from the date of listing	30.77	255,632	255,632	255,632	255,632
Grant II	04-Mar-11	2 years from the date of listing	30.77	38,584	38,584	38,584	38,584
Grant III	16-Nov-12	2 years from the date of listing	76.92	27,196	27,196	27,196	27,196
Grant IV	02-Jul-13	2 years from the date of listing	76.92	18,707	18,707	18,707	18,707
Grant V	28-Jan-15	2 years from the date of listing	76.92	17,132	17,132	17,132	21,814

**(d) Fair value of options granted**

No grants were issued during the respective period/ years.

**(e) Expense arising from share-based payment transactions**

Total expenses arising from share-based payment transactions recognised in profit or loss as part of employee benefit expense were :

30 June 2021: INR NIL (31 March 2021 : INR NIL ; 31 March 2020: INR NIL and 31 March 2019: INR NIL).

(f) The existing Employee Stock Option Scheme 2011 has been discontinued and no fresh options will be granted under this scheme. A new Employee Stock Option Plan 2021 (ESOP 2021) was adopted in line with Securities and Exchange Board of India (Share Based Employee Benefits) Regulations, 2014 and the same was approved pursuant to a Board resolution dated 3 August 2021 and shareholders' resolution dated 7 August 2021. The ESOP 2021 scheme was further amended in order to align the same with the Securities and Exchange Board of India (Share Based Employee Benefits and Sweat Equity) Regulations, 2021 notified on 13 August 2021 and the same has been approved pursuant to a Board resolution dated 10 November 2021. Under the new scheme, no options have been granted, vested and exercised till date.

**Note: 48**

The following Note has been reproduced from the consolidated financial statements of Tega Industries Chile SpA for the year ended 31 March 2020 (herein after referred to as the Company/ Group), a step down subsidiary of the Tega Industries Limited ("holding company"):

**"Financial Position of Tega Industries Chile SpA and its Subsidiaries:**

As of March 31, 2020, the Company has negative working capital of TH\$ 1,840,539, and profit for the period of TH\$ 1,572,600.

The year ending March 2020 saw 56 per cent increase in revenues, which was as per the plan prepared by the Company at the start of Financial Year 2019-2020. The Company has budgeted an increase of 36 per cent in revenue growth in the year 2020-2021.

The budgeted growth is possible due to the huge traction and acceptability of the product Dynaprime within the mining companies in Chile and other part of the LATAM. The said product provided extended benefits to the mining companies including improved safety. With the above and based on the estimated revenue growth in the upcoming years, Management is of the view that there is virtual certainty to absorb the accumulated tax losses in the next 3-4 years and accordingly deferred tax assets has been recognised in the year ending March 2020. The Company can affirm that the economic performance of the company's product is an exclusive reflection of the growth.

As of March 31, 2019, The Company had negative working capital of TH\$ 4,567,385 and a loss for the period of TH\$ 2,927,868.

In this regard, Management declares that during period 2018, a new strategy was implemented for the company, which involved capitalizing the loans into a Capital amount of TH\$ 20,752,397 to improve the net worth of the company. Also, it involved a contribution of working capital from the parent company.

It should be noted that during the current fiscal year, Tega took part in several tests with customers for its product "Combiliner" with positive results and executed orders and contracts for some customers. Tega recorded EBITDA of TH\$ 594,000 in FY 2018 and 2019. In the last six months Tega has earned EBITDA of TH\$ 1,039,000.

This a major change for the Company and Management regarding performance in coming years, which will make the Company profitable and will enable it to improve the working capital cycle. Therefore, enhanced performance and the permanent support of the parent Company leaves no doubt as regards Company's ability to continue as a going concern.

**Significant Events**

The accompanying consolidated financial statements have been prepared on a going concern basis, which considers the realization of assets and the settlement of liabilities in the normal course of operations. The Group presents a net profit of TH\$ 1,572,600 in the annual period ended March 31, 2020. At that date, it also presents a negative working capital of TH\$ 1,840,539 and will require additional working capital during the 2020/2021 period to support a sustainable business operation. The Group's debt is a short-term one, which corresponds to debts to financial entities (23.18%), suppliers (10.41%), and related entities (66.41%). However, the Group's liquidity has not been affected, as it is fully guaranteed by the Parent, Tega Industries Limited in India."



The following Note has been reproduced from the consolidated financial statements of Tega Industries Chile SpA for the year ended 31 March 2019 (herein after referred to as the Company/ Group), a step down subsidiary of the Tega Industries Limited ("holding company"):

"Equity

**Issued capital**

At the date of financial statements, the Company has a subscribed and the paid-in capital of M\$ 27,819,359.

**Paid-in capital and/or capital increase**

<b>Date</b>	<b>Issuing Company</b>	<b>Amount in M\$</b>	<b>Condition</b>
07/08/2018	Tega Industries Chile SPA	1,306,904	It was paid by means of a credit capitalization between Tega Holding PTE ltd. (Singapore) and Tega Industries Chile SPA
31/12/2018	Tega Industries Chile SPA	537,848	It was paid by means of a credit capitalization between Tega Holding PTE ltd. (Singapore) and Tega Industries Chile SPA
28/03/2019	Tega Industries Chile SPA	18,907,644	It was paid by means of a credit capitalization between Tega Holding PTE ltd. (Singapore) and Tega Industries Chile SPA
<b>Total Paid in Capital and / or Capital increase</b>		<b>20,752,396</b>	

**Dividend Provisioned for and/or paid**

No dividends were paid in 2019 and 2018

**Treasury Shares**

During November 2016, Tega Industries Chile SpA absorbed the company Tega Holding Chile SpA, which was a shareholder of Tega Industries Chile SpA. Accordingly, the shares owned by Tega Holding Chile SpA are now owned by Tega Industries Chile SpA, thus owning itself, pursuant to (section 27, No. 2) of Act N°18,046.

Tega's Management is committed to regularising these treasury shares during the business year 2019 through a capital decrease and restructuring of equity.

**Financial Position of Tega Industries Chile SpA and its Subsidiaries**

As of March 31, 2019, the Company has negative working capital of M\$ 4,567,385, and a loss for the period of M\$ 2,927,868.

As at 31 March 2018, the Company has a negative working capital of M\$ 5,829,639, and a profit for the period M\$88,034.

**Management Representation as at 31 March 2019**

In this regard, Management declares that during period 2018, a new strategy was implemented for the company, which involved capitalizing the loans into Capital amount of 20,752.40 Million CLP to improve the net worth of the company. Also, it involved a contribution of working capital from the parent company.

It should be noted that during the current fiscal year, Tega took part in several tests with customers for its product "Combiliner" with positive results and executed orders and contracts for some customers. Tega booked EBITDA of 594 Million CLP in the FY 2018 -2019. In the last six months Tega has earned a EBITDA of 1039 Million CLP.

This is a complete turnaround of the company and the management foresight's further improvement in performance in coming years which will make company profitable and improve working capital cycle. Therefore, improved performance and continuous support from parent does not leave any doubt on the going concern of the company."

**Note: 49**

Pursuant to a shareholders' agreement ("agreement") in 2011, Wagner Limited ("Investor") acquired equity shares in the Holding Company and subscribed to Compulsorily Convertible Participatory Preference Shares ("CCPP") issued by the Holding Company, collectively referred to as securities. The amount pertaining to these securities was recognised as equity share capital, preference share capital and securities premium under the previous GAAP.

Pursuant to the said agreement, the Investor, has an option to require an exit by way of buyback of the securities at fair value in case the Holding Company does not conduct an IPO within a stipulated date. Per Ind AS 32 'Financial Instruments: Presentation' this represents a contractual obligation to deliver cash or another financial asset and hence such securities are required to be classified as a financial liability and measured at fair value. However, there remains certain contradictions between the Ind AS and the Companies Act, 2013 with regard to classification and measurement of such securities. Classification and measurement of the securities as a financial liability, in accordance with the principles of Ind AS 32 and Ind AS 109 'Financial Instruments' would not be in accordance with the provisions of the Companies Act, 2013, which requires share capital received to be classified under share capital and securities premium received to be classified under securities premium account. Considering that the rule of construction requires that the Act prevails over any subordinate legislation like the Companies (Indian Accounting Standards) Rules, 2015, the Holding Company did not classify and measure the securities in accordance with the requirements of Ind AS 32 and Ind AS 109 on the date of transition to Ind AS i.e. 1 April 2016. The Holding Company has continued the classification done under previous GAAP in the following years also pending resolution of such contradiction. The option to exercise buyback of securities at fair value exposes the investor to the equity price risk similar to an equity share. Further, the Holding Company has not included the disclosures required under Ind AS 107 'Financial Instruments: Disclosures' and has not complied with the presentation requirements of Ind AS 1 'Presentation of financial statements'.

If the securities were classified and measured as per Ind AS 32 and Ind AS 109, total liabilities would be higher by INR 2,492.21 Mn as at 30 June 2021 (INR 2,390.68 Mn as at 31 March 2021, INR 1,821.34 Mn as at 31 March 2020 and INR 1,629.89 Mn as at 31 March 2019) and profit before tax would be lower by INR 101.53 Mn for the three months period ended 30 June 2021 (INR 569.34 Mn for the year ended 31 March 2021, INR 191.45 Mn for the year ended 31 March 2020 and INR 99.99 Mn for the year ended 31 March 2019).

Note: 50 Additional Information required by Schedule III of the Companies Act, 2013:

Particulars	Net Assets (total assets minus total liabilities)		Share in Profit or (Loss)		Share in other comprehensive income (OCI)		Share in total comprehensive income (OCI)	
	As % of Consolidated Net Assets	Amount	As % of Consolidated Profit or (Loss)	Amount	As % of Consolidated OCI	Amount	As % of Consolidated total comprehensive income	Amount
<b>Parent</b>								
<b>Tega Industries Limited</b>								
30 June 2021	130.68%	8,247.72	156.95%	186.49	-3.25%	(1.80)	105.96%	184.69
31 March 2021	131.38%	8,063.02	200.55%	2,735.53	1.66%	2.33	181.96%	2,737.86
31 March 2020	118.38%	5,475.26	98.42%	644.67	8.40%	(4.14)	105.74%	640.53
31 March 2019	116.69%	4,680.39	154.37%	504.31	3.59%	(3.17)	210.31%	501.14
<b>Subsidiaries - Foreign</b>								
<b>1 Tega Industries, Inc.</b>								
30 June 2021	2.80%	176.82	0.34%	0.40	-	-	0.23%	0.40
31 March 2021	2.83%	173.52	4.07%	55.56	-	-	3.69%	55.56
31 March 2020	2.66%	122.85	0.59%	3.87	-	-	0.64%	3.87
31 March 2019	2.71%	108.52	-0.56%	(1.82)	-	-	-0.76%	(1.82)
<b>2 Tega Industries Australia Pty. Ltd.</b>								
30 June 2021	1.07%	67.78	6.13%	7.29	-	-	4.18%	7.29
31 March 2021	0.99%	60.51	0.02%	0.26	-	-	0.02%	0.26
31 March 2020	1.08%	49.83	-7.74%	(50.69)	-	-	-8.37%	(50.69)
31 March 2019	2.61%	104.66	-3.77%	(12.23)	-	-	-5.18%	(12.23)
<b>3 Tega Investments Limited</b>								
30 June 2021	0.23%	14.67	-1.81%	(2.15)	-	-	-1.24%	(2.15)
31 March 2021	0.27%	16.57	5.38%	73.39	-	-	4.88%	73.39
31 March 2020	-1.25%	(57.79)	-0.68%	(4.47)	-	-	-0.74%	(4.47)
31 March 2019	-1.21%	(48.47)	-2.50%	(8.17)	-	-	-3.43%	(8.17)
<b>4 Tega Industries Canada Inc.</b>								
30 June 2021	1.39%	87.45	21.71%	25.79	-	-	14.80%	25.79
31 March 2021	0.97%	59.78	2.23%	30.39	-	-	2.02%	30.39
31 March 2020	0.36%	25.99	1.73%	11.33	-	-	1.87%	11.33
31 March 2019	0.35%	14.00	-14.74%	(48.17)	-	-	-20.21%	(48.17)
<b>5 Tega Do Brasil Servicos Tecnicos Ltda</b>								
30 June 2021	0.08%	4.98	3.44%	4.08	-	-	2.34%	4.08
31 March 2021	0.01%	0.57	0.02%	0.23	-	-	0.02%	0.23
31 March 2020	0.01%	0.41	-0.81%	(5.28)	-	-	-0.87%	(5.28)
31 March 2019	0.15%	5.95	0.36%	1.16	-	-	0.49%	1.16
<b>6 Tega Holdings Pte Limited</b>								
30 June 2021	-15.65%	(987.65)	-80.64%	(95.82)	-	-	-54.97%	(95.82)
31 March 2021	-14.28%	(876.26)	-	1,670.20	-	-	111.00%	1,670.20
31 March 2020	-53.68%	(2,482.60)	19.77%	129.48	-	-	21.37%	129.48
31 March 2019	-62.76%	(2,517.38)	-16.67%	(54.45)	-	-	-22.83%	(54.45)
<b>7 Tega Holdings Pty Ltd</b>								
30 June 2021	5.78%	364.57	-4.88%	(5.80)	-	-	-3.33%	(5.80)
31 March 2021	6.03%	369.85	-1.67%	(22.77)	-	-	-1.51%	(22.77)
31 March 2020	7.04%	325.49	1.40%	9.18	-	-	1.52%	9.18
31 March 2019	8.40%	336.94	11.34%	37.04	-	-	15.54%	37.04
<b>8 Tega Scanning Solutions Inc.#</b>								
30 June 2021	-	-	-	-	-	-	-	-
31 March 2021	-	-	-	-	-	-	-	-
31 March 2020	-	-	-	-	-	-	-	-
31 March 2019	-	-	0.54%	1.78	-	-	0.75%	1.78
<b>9 Losugen Pty Ltd</b>								
30 June 2021	2.08%	131.05	0.08%	0.09	-	-	0.05%	0.09
31 March 2021	2.13%	130.80	0.88%	12.03	-	-	0.80%	12.03
31 March 2020	2.12%	97.86	3.30%	21.59	-	-	3.56%	21.59
31 March 2019	2.77%	110.93	19.05%	62.25	-	-	26.12%	62.25
<b>10 Tega Industries Chile SpA*</b>								
30 June 2021	3.79%	239.07	-25.41%	(30.19)	-0.52%	(0.29)	-17.49%	(30.48)
31 March 2021	4.15%	254.63	16.64%	227.01	-3.20%	(4.50)	14.79%	222.51
31 March 2020	0.45%	20.98	22.72%	148.80	-	-	24.56%	148.80
31 March 2019	-3.50%	(140.29)	-96.30%	(314.60)	-	-	-132.03%	(314.60)
<b>11 Tega Investments South Africa Proprietary Limited</b>								
30 June 2021	0.78%	49.09	0.63%	0.75	-	-	0.43%	0.75
31 March 2021	0.75%	45.87	-0.01%	(0.11)	-	-	-0.01%	(0.11)
31 March 2020	0.85%	39.44	0.00% ^	0.03	-	-	0.00% ^	0.03
31 March 2019	1.11%	44.42	-0.06%	(0.19)	-	-	-0.08%	(0.19)
<b>12 Tega Industries Africa Proprietary Limited</b>								
30 June 2021	8.76%	553.15	0.25%	0.29	-	-	0.17%	0.29
31 March 2021	8.56%	525.42	9.18%	125.17	-	-	8.32%	125.17
31 March 2020	7.25%	335.19	0.98%	6.41	-	-	1.06%	6.41
31 March 2019	9.25%	371.21	-0.81%	(2.65)	-	-	-1.11%	(2.65)
<b>Minority Interest in all subsidiaries</b>								
30 June 2021	0.00% ^	0.00 ^	0.00% ^	0.00 ^	0.00% ^	0.00 ^	0.00% ^	0.00 ^
31 March 2021	0.00% ^	0.00 ^	0.00% ^	0.00 ^	0.00% ^	0.00 ^	0.00% ^	0.00 ^
31 March 2020	0.00% ^	0.00 ^	0.00% ^	0.00 ^	0.00% ^	0.00 ^	0.00% ^	0.00 ^
31 March 2019	0.00% ^	0.00 ^	0.13%	0.42	0.00% ^	0.00 ^	0.18%	0.42
<b>Joint venture - Indian</b>								
<b>1 Hosh Equipment (India) Limited</b>								
30 June 2021	4.36%	275.33	5.18%	6.16	-0.09%	(0.05)	3.51%	6.11
31 March 2021	4.39%	269.22	1.96%	26.78	0.02%	0.03	1.78%	26.81
31 March 2020	5.29%	244.66	2.76%	18.09	0.04%	(0.02)	2.98%	18.07
31 March 2019	5.85%	234.64	5.54%	18.09	0.85%	(0.75)	7.28%	17.34
<b>Adjustment arising out of Consolidation</b>								
30 June 2021	-46.15%	(2,912.51)	18.03%	21.44	103.86%	57.62	45.36%	79.06
31 March 2021	-48.18%	(2,956.28)	-261.69%	(3,569.62)	101.52%	142.77	-227.76%	(3,426.85)
31 March 2020	9.24%	427.32	-42.44%	(277.97)	91.56%	(45.11)	-53.32%	(323.08)
31 March 2019	17.58%	705.53	44.08%	144.03	95.57%	(84.49)	24.98%	59.54
<b>Total 30 June 2021</b>	100.00%	6,311.52	100.00%	118.82	100.00%	55.48	100.00%	174.30
<b>Total 31 March 2021</b>	100.00%	6,137.22	100.00%	1,364.05	100.00%	140.63	100.00%	1,504.68
<b>Total 31 March 2020</b>	100.00%	4,624.89	100.00%	655.04	100.00%	(49.27)	100.00%	605.77
<b>Total 31 March 2019</b>	100.00%	4,011.05	100.00%	326.70	100.00%	(88.41)	100.00%	238.29

^ Amount is below the rounding off norm adopted by the Group.

# Disposed off during the year ended 31 March 2019 u.e.f. 15 January 2019

\* includes information related to Tega Industries Chile SpA and its subsidiaries.

**Note: 51**

The Code on Social Security, 2020 ('Code') relating to employee benefits during employment and post employment received Indian Parliament approval and Presidential assent in September 2020. The Code has been published in the Gazette of India and subsequently on 13 November 2020 draft rules were published and invited for stakeholders' suggestions. However, the date on which the Code will come into effect has not been notified. The Holding Company and its Joint Venture will assess the impact of the Code when it comes into effect and will record any related impact in the period the Code becomes effective.

**Note: 52**

The Group is engaged in the business of designing, manufacturing and installation of process equipment and accessories to cater the mineral processing, mining, material handling and environment industries. The Group has assessed the possible impact of COVID-19 on its Restated Consolidated Financial Information based on the internal and external information available up to the date of approval of these Restated Consolidated Financial Information and concluded no adjustment is required in these Restated Consolidated Financial Information. The Group has made a detailed assessment of its liquidity position for the next one year and of the recoverability and carrying value of its assets, including but not limited to Property, Plant and Equipment, Intangible Assets, Trade Receivables and Investments as at the Balance sheet date. The Group continues to monitor the impact of COVID-19 and the future economic conditions.

**Note: 53**

(a) The Holding Company had received foreign direct investment for issue of 668,637 compulsorily convertible participatory preference shares ("CCPP") on 11 May 2011 to Wagner Limited and thereafter issued bonus shares comprising (922,716 equity shares and 8,023,644 CCPP) to Wagner Limited on 5 October 2013. As per Para 9(1)(B) of Schedule I to the Foreign Exchange Management (Transfer or issue of security by a person resident outside India) Regulations, 2000 vide Notification no. FEMA 20/2000-RB dated 3 May 2000, amended from time to time, an Indian company is required to file Form FC-GPR to the Regional Office concerned of Reserve Bank of India ("RBI") with respect to issuance of shares to foreign investor within 30 days from the date of issue. It was observed that there has been an inadvertent delay in filing of Form FC-GPR, which is in contravention of the aforesaid regulation. On 6 August 2021, the management has made an application to RBI in accordance with Foreign Exchange Management Act, 1999 for compounding of contravention. Subsequent query raised by RBI was duly replied by the Holding Company. While further reply on compounding application from RBI is awaited, based on the assessment by the management, the impact of the said contravention is not expected to be material on the Restated Consolidated Financial Information.

(b) The Holding Company has issued certain stock options as part of Employee Stock Option Plan 2011 ("ESOP 2011") to non-resident employees outside India. Five grants (Grant I to V) were made by the Holding Company in four tranches on various dates being 4 March 2011, 16 November 2012, 2 July 2013 and 28 January 2015, respectively. As per regulation 8 to the Foreign Exchange Management (Transfer or issue of security by a person resident outside India) Regulations, 2000 vide Notification no. FEMA 20/2000-RB dated 3 May 2000, amended from time to time, an Indian company is required to file Form ESOP to the Regional Office concerned of Reserve Bank of India ("RBI") with respect to issue of stock options to non-resident employees within 30 days from the date of issue. It was observed that there has been an inadvertent delay in filing of Form ESOP, which is in contravention of the aforesaid regulation. On 7 August 2021, management wrote a letter to RBI for filing Form ESOP in Foreign Investment Reporting and Management System (FIRMS), an online portal. On 10 August 2021 for the first tranche of grant made on 4 March 2011, Form ESOP was filed via FIRMS which was subsequently rejected. Subsequently, forms for all four tranches have been duly filed with RBI on 8 September 2021, 20 September 2021, 24 September 2021 and 30 September 2021 respectively. The RBI vide its letter dated 27 October 2021 has acknowledged the aforesaid forms submitted by the Holding Company subject to application by the Holding Company for compounding of the contravention of aforesaid Regulation. On 1 November 2021, the management made an application to RBI in accordance with Foreign Exchange Management (Transfer or Issue of Security by a Person Resident outside India) Regulations, 2000 for compounding of contravention. While further reply on compounding application from RBI is awaited, based on the assessment by the management, the impact of the said contravention is not expected to be material on the Restated Consolidated Financial Information.

(c) As at 30 June 2021, foreign currency receivables amounting to INR 1.91 Mn, due for more than the time period permitted under the Master Direction on Export of goods and Services vide FED Master Direction No. 16/2015-16 dated 1 January 2016 (as amended), issued by the Reserve Bank of India (RBI). The Holding Company has approached the Authorised Dealer (AD) Bank seeking to self-write off the said amount under aforesaid regulation since the amount has been deducted by the customer on account of late delivery charges. AD bank has confirmed that amount is eligible for self-write off subject to fulfillment of conditions mentioned in aforesaid regulation. Currently, Holding Company is in the process of completing the procedures required to fulfill those conditions. Based on the assessment by the management, the impact of the said contravention is not expected to be material on the Restated Consolidated Financial Information.

(d) As at 30 June 2021, foreign currency payables with respect to Merchanting Trade Transaction amounting to INR 5.84 Mn and other import dues amounting to INR 0.47 million, outstanding beyond the time period permitted under the Master Direction on Import of Goods and Services vide FED Master Direction No. 17/2016-17 dated January 1, 2016 (as amended), issued by the Reserve Bank of India (RBI). The Holding Company has submitted application to AD bank seeking approval for making payment in case of Merchanting Trade Transaction since all the related exports proceeds have been realised and seeking extension of time in case of other import dues since payments are outstanding on account of quality issues. Based on the assessment by the management, the impact of the said contravention is not expected to be material on the Restated Consolidated Financial Information.

**Note: 54 Relationship with Struck off Companies**

The Group and its Joint Venture has no transactions with companies struck off under section 248 of the Companies Act, 2013 or section 560 of the Companies Act, 1956.

**Note: 55 Reconciliation of quarterly bank returns**

Quarter	Particulars	Name of the bank	Amount as per books of account	Amount as reported in the quarterly returns/ statements	Amount of difference
30 June 2021	Stock	Working Capital Lenders*	1,390.29	1,113.86	(276.43)
30 June 2021	Debtors	Working Capital Lenders*	1,590.71	1,763.69	172.98
30 June 2021	Creditors	Working Capital Lenders*	750.76	657.22	(93.54)
31 March 2021	Stock	Working Capital Lenders*	1,080.47	1,022.18	(58.29)
31 March 2021	Debtors	Working Capital Lenders*	1,795.50	1,840.85	45.35
31 March 2021	Creditors	Working Capital Lenders*	634.53	670.99	36.46
31 December 2020	Stock	Working Capital Lenders*	746.58	716.86	(29.72)
31 December 2020	Debtors	Working Capital Lenders*	2,352.61	2,182.66	(169.95)
31 December 2020	Creditors	Working Capital Lenders*	382.30	387.96	5.66
30 September 2020	Stock	Working Capital Lenders*	723.09	697.58	(25.51)
30 September 2020	Debtors	Working Capital Lenders*	2,288.74	2,331.80	43.06
30 September 2020	Creditors	Working Capital Lenders*	354.75	362.22	7.47
30 June 2020	Stock	Working Capital Lenders*	750.73	725.22	(25.51)
30 June 2020	Debtors	Working Capital Lenders*	2,048.27	2,001.29	(46.98)
30 June 2020	Creditors	Working Capital Lenders*	262.45	271.51	9.06
31 March 2020	Stock	Working Capital Lenders*	876.85	861.37	(15.48)
31 March 2020	Debtors	Working Capital Lenders*	1,891.56	1,929.72	38.16
31 March 2020	Creditors	Working Capital Lenders*	372.12	362.60	(9.52)
31 December 2019	Stock	Working Capital Lenders*	802.45	762.20	(40.25)
31 December 2019	Debtors	Working Capital Lenders*	2,058.31	2,116.29	57.98
31 December 2019	Creditors	Working Capital Lenders*	229.18	245.94	16.76
30 September 2019	Stock	Working Capital Lenders*	846.13	789.80	(56.33)
30 September 2019	Debtors	Working Capital Lenders*	2,229.57	2,299.84	70.27
30 September 2019	Creditors	Working Capital Lenders*	316.53	290.35	(26.18)
30 June 2019	Stock	Working Capital Lenders*	813.70	767.01	(46.69)
30 June 2019	Debtors	Working Capital Lenders*	2,485.86	2,264.82	(221.04)
30 June 2019	Creditors	Working Capital Lenders*	395.75	370.16	(25.59)
31 March 2019	Stock	Working Capital Lenders*	782.84	714.33	(68.51)
31 March 2019	Debtors	Working Capital Lenders*	2,250.08	2,279.91	29.83
31 March 2019	Creditors	Working Capital Lenders*	594.61	575.34	(19.27)
31 December 2018	Stock	Working Capital Lenders*	729.02	696.31	(32.71)
31 December 2018	Debtors	Working Capital Lenders*	2,234.80	2,212.53	(22.27)
31 December 2018	Creditors	Working Capital Lenders*	403.27	317.76	(85.51)
30 September 2018	Stock	Working Capital Lenders*	682.94	650.23	(32.71)
30 September 2018	Debtors	Working Capital Lenders*	2,243.91	2,297.84	53.93
30 September 2018	Creditors	Working Capital Lenders*	343.60	226.54	(117.06)
30 June 2018	Stock	Working Capital Lenders*	627.97	615.60	(12.37)
30 June 2018	Debtors	Working Capital Lenders*	2,193.34	2,168.18	(25.16)
30 June 2018	Creditors	Working Capital Lenders*	406.80	353.85	(52.95)

\* ICICI Bank Limited, Standard Chartered Bank, Axis Bank Limited, RBL Bank Limited, CITI Bank N.A, Yes Bank Limited and Syndicate Bank are represented as Working Capital Lenders.

**Note for discrepancies :**

The Bank returns were prepared and filed before the completion of all financial statement closure activities including Ind AS related adjustments/ reclassifications, as applicable, which led to these differences between the final books of accounts and the bank return which were based on provisional books of accounts.

**Tega Industries Limited**  
**CIN: U25199WB1976PLC030532**  
**Annexure V - Notes to the Restated Consolidated Financial Information**

(All amounts in INR million, unless otherwise stated)

**Note: 56 Ratios analysis and its element:**

**Ratios**

Particulars	30 June 2021	31 March 2021	31 March 2020	31 March 2019	% change from 31 March 2021 to 30 June 2021 *	% change from 31 March 2020 to 31 March 2021	% change from 31 March 2019 to 31 March 2020
(a) Current Ratio	2.23	2.25	1.82	1.48	(0.89%) #	23.63%	22.97%
(b) Debt-Equity Ratio	0.29	0.31	0.53	0.53	(6.45%) #	-41.58%	0.00%
(c) Debt Service Coverage Ratio	1.15	6.22	3.58	2.24	NA*	73.74%	59.82%
(d) Return on Equity Ratio	1.88%	22.23%	14.16%	8.14%	NA*	56.99%	73.96%
(e) Inventory turnover ratio	0.33	2.04	2.06	2.13	NA*	-0.97%	-3.29%
(f) Trade Receivables turnover ratio	1.01	3.59	3.61	2.94	NA*	-0.55%	22.79%
(g) Trade payables turnover ratio	1.33	4.99	6.77	5.16	NA*	-26.29%	31.20%
(h) Net capital turnover ratio	0.27	1.31	1.48	1.58	NA*	-11.49%	-6.33%
(i) Net profit ratio	6.86%	16.93%	9.56%	5.15%	NA*	77.41%	85.63%
(j) Return on Capital employed	2.35%	24.76%	11.17%	11.12%	NA*	121.67%	0.45%
(k) Return on investment	1.79%	19.32%	8.25%	7.83%	NA*	134.18%	5.36%

# Change in ratio is not more than 25%

\* The numbers for three months period ended 30 June 2021 are not comparable to that of the year ended 31 March 2021 and hence not explained.

**Elements of Ratios**

Ratios	30 June 2021		31 March 2021		31 March 2020		31 March 2019	
	Numerator	Denominator	Numerator	Denominator	Numerator	Denominator	Numerator	Denominator
(a) Current Ratio	6,722.34	3,013.99	6,227.15	2,769.42	5,192.56	2,848.81	4,378.80	2,965.51
(b) Debt-Equity Ratio	1,842.38	6,311.52	1,878.02	6,137.22	2,439.34	4,624.89	2,126.90	4,011.05
(c) Debt Service Coverage Ratio	302.96	264.49	2,413.20	387.98	1,190.37	332.29	1,078.12	480.59
(d) Return on Equity Ratio	118.82	6,311.52	1,364.05	6,137.22	655.04	4,624.89	326.70	4,011.05
(e) Inventory turnover ratio	685.47	2,078.66	3,237.90	1,586.31	2,738.36	1,326.30	2,573.83	1,210.58
(f) Trade Receivables turnover ratio	1,711.85	1,697.76	7,936.43	2,208.64	6,690.02	1,852.18	6,193.04	2,103.24
(g) Trade payables turnover ratio	1,561.03	1,174.44	4,928.44	987.10	4,418.65	652.96	4,165.44	806.83
(h) Net capital turnover ratio	1,732.07	6,311.52	8,055.22	6,137.22	6,848.47	4,624.89	6,337.57	4,011.05
(i) Net profit ratio	118.82	1,732.07	1,364.05	8,055.22	655.04	6,848.47	326.70	6,337.57
(j) Return on Capital employed	191.80	8,153.90	1,984.62	8,015.24	788.73	7,064.23	682.48	6,137.95
(k) Return on investment	188.86	10,561.72	1,967.91	10,183.39	731.90	8,873.15	618.88	7,902.68

Note: 56 Ratios analysis and its element:

Reasons for change more than 25%:	Numerator	Denominator	% change from 31 March 2020 to 31 March 2021	% change from 31 March 2019 to 31 March 2020
(a) Current Ratio	Current Assets	Current Liabilities	Change in ratio is not more than 25%	Change in ratio is not more than 25%
(b) Debt-Equity Ratio	Borrowings	Total Equity	Lower due to : Repayment of debt and generations of higher operating cash flows.	Change in ratio is not more than 25%
(c) Debt Service Coverage Ratio	Restated Profit Before Tax + Finance costs + Depreciation and amortisation expenses	Finance Costs + Current maturities of long-term debt	Higher due to: Generations of higher operating cash flows resulting in higher Earnings before interest depreciation and taxes	Higher due to: Generations of higher operating cash flows resulting in higher Earnings before interest depreciation and taxes
(d) Return on Equity Ratio	Restated total profit for the period/ year	Total Equity	Higher due to: Higher Profits due to increase in Revenue from Operations.	Higher due to: Higher Profits due to increase in Revenue from Operations. Also recognition of Deferred tax assets in FY 20 on accumulated losses in one of the subsidiary has lead to higher profits.
(e) Inventory turnover ratio	Cost of materials consumed + Changes in inventories of finished goods and work-in-progress	Inventories	Change in ratio is not more than 25%	Change in ratio is not more than 25%
(f) Trade Receivables turnover ratio	Revenue from operations - Duty drawback and other export incentives	Trade receivables and contract assets	Change in ratio is not more than 25%	Change in ratio is not more than 25%
(g) Trade payables turnover ratio	Purchases + Other Expenses - (Bank charges + Directors' sitting fees + Allowance for expected credit loss + Warranty Expenses + Rates and taxes + Derivatives at FVTPL + Expenditure on corporate social responsibility activities + Net loss on foreign currency transaction and translations + Net loss on sale of property, plant and equipment + Loss on disposal of a subsidiary)	Trade Payables	Lower due to : Higher purchase during the last quarter of the year ended March 31, 2021	Higher due to : Generations of higher operating cash flows as a result of increase in revenue from operations used for liquidation of trade payables.
(h) Net capital turnover ratio	Revenue from operations	Total Equity	Change in ratio is not more than 25%	Change in ratio is not more than 25%
(i) Net profit ratio	Restated total profit for the period/ year	Revenue from operations	Higher due to :Higher Profits due to increase in Revenue from Operations.	Higher due to: Higher Profits due to increase in Revenue from Operations. Also recognition of Deferred tax assets in FY 20 on accumulated losses in one of the subsidiary has lead to higher profits.
(j) Return on Capital employed	Restated profit before share of restated net profit of joint venture accounted for using equity method and tax + Finance costs	Total Equity + Borrowings	Higher due to: Repayment of debt and generations of higher operating cash flows and also higher Profits due to increase in Revenue from Operations	Change in ratio is not more than 25%
(k) Return on investment	Restated profit before tax + Finance costs * (1 - tax rate#)	Total assets	Higher due to :Higher Profits due to increase in Revenue from Operations.	Change in ratio is not more than 25%

# as applicable to Holding Company

**Note: 57**

The Holding Company has granted loans and made investments in some of its foreign subsidiaries (intermediaries) with the understanding that the intermediaries shall directly or indirectly lend/ invest the said funds in other entities identified by the Holding Company. The said transactions are getting eliminated at the time of preparation of the Consolidated Financial Statements as at each reporting periods, hence the details of the said transactions are not reported in the Restated Consolidated Financial Informations.

**Note: 58**

(a) Subsequent to the three months period ended 30 June 2021, the Holding Company has filed Draft Red Herring Prospectus ("DRHP") with the Securities and Exchange Board of India ("SEBI"), National Stock Exchange of India Limited and BSE Limited in connection with proposed Initial Public Offering ("IPO") of its equity shares.

(b) Subsequent to 30 June 2021, the Board of Directors vide resolution dated 10 November 2021 has approved the conversion of the aforesaid CCPP into equity shares as per the terms of conversion, subject to shareholders approval.

**Signature to Note 1 to 58 above.**

**For Price Waterhouse & Co Bangalore LLP**  
Firm Registration Number: 007567S/S-200012  
Chartered Accountants

**For and on behalf of Board of Directors**

Avijit Mukerji  
Partner  
Membership Number: 056155

Madan Mohan Mohanka  
Chairman  
DIN: 00049388

Mehul Mohanka  
Managing Director  
DIN: 00052134

Sudipta Bhowal  
Company Secretary

Manoj Kumar Agarwal  
Chief Financial Officer

Place : Kolkata  
Date : 10 November 2021

Place : Kolkata  
Date : 10 November 2021



Summarized below are the restatement adjustments made to the Audited Special Purpose Interim Consolidated Financial Statements for the three months period ended June 30, 2021 and Audited Consolidated Financial Statements for the years ended March 31, 2021, March 31, 2020 and March 31, 2019 and their impact on equity and the profit of the Group and its joint venture:

**Part A: Statement of Adjustments to Audited Special Purpose Interim Consolidated Financial Statements and Audited Consolidated Financial Statements**

**Reconciliation between audited equity and restated equity:**

Particulars	Note No.	30 June 2021	31 March 2021	31 March 2020	31 March 2019
<b>Total Equity as per Audited Special Purpose Interim Consolidated Financial Statements and Audited Consolidated Financial Statements</b>		6,311.52	6,137.22	4,624.89	4,020.51
<b>Restatement adjustments:</b>					
Change in Accounting Policies					
a. Ind AS 116- Leases	I	-	-	-	(14.26)
b. Deferred tax impact on adjustments in (a), as applicable		-	-	-	4.60
c. Exchange differences on translation of foreign operations on (a) and (b) above		-	-	-	0.20
<b>Total impact of restatement adjustments</b>		-	-	-	<b>(9.46)</b>
<b>Total equity as per Restated Consolidated Financial Information</b>		<b>6,311.52</b>	<b>6,137.22</b>	<b>4,624.89</b>	<b>4,011.05</b>

**Reconciliation between audited total comprehensive income and restated total comprehensive income:**

Particulars	Note No.	For three months period ended 30 June 2021	For year ended 31 March 2021	For year ended 31 March 2020	For year ended 31 March 2019
<b>A. Total profit as per Audited Special Purpose Interim Consolidated Financial Statements and Audited Consolidated Financial Statements</b>		118.82	1,364.05	655.04	336.36
<b>Restatement adjustments:</b>					
Impact of Ind AS 116	I	-	-	-	(51.34)
(Increase)/ decrease in expenses		-	-	-	(29.11)
Depreciation of Right-of-Use Assets*		-	-	-	66.28
Interest expense on lease liabilities#		-	-	-	(0.09)
Other expenses##		-	-	-	4.60
Change in share of restated profit of joint venture accounted for using the equity method		-	-	-	-
Deferred tax impact on Ind AS 116 adjustments		-	-	-	4.60
<b>Total impact of restatement adjustments (a)</b>		-	-	-	<b>(9.66)</b>
<b>Restated total profit as per Restated Consolidated Statement of Profit and Loss</b>		<b>118.82</b>	<b>1,364.05</b>	<b>655.04</b>	<b>326.70</b>
<b>B. Other comprehensive income as per Audited Special Purpose Interim Consolidated Financial Statements and Audited Consolidated Financial Statements</b>		55.48	140.63	(49.27)	(88.61)
<b>Restatement adjustments:</b>					
Exchange differences on translation of foreign operations		-	-	-	0.20
<b>Total impact of restatement adjustments (b)</b>		-	-	-	<b>0.20</b>
<b>Restated other comprehensive income as per Restated Consolidated Statement of Profit and Loss</b>		<b>55.48</b>	<b>140.63</b>	<b>(49.27)</b>	<b>(88.41)</b>
<b>C. Total comprehensive income as per Audited Special Purpose Interim Consolidated Financial Statements and Audited Consolidated Financial Statements</b>		<b>174.30</b>	<b>1,504.68</b>	<b>605.77</b>	<b>247.75</b>
<b>Total restatement adjustments (a+b)</b>		-	-	-	<b>(9.46)</b>
<b>Restated total comprehensive income as per Restated Consolidated Statement of Profit and Loss</b>		<b>174.30</b>	<b>1,504.68</b>	<b>605.77</b>	<b>238.29</b>

\* the Company had leasehold land and plant and equipment which were accounted as 'finance lease' under Ind AS 17, Leases. INR 0.62 Mn relates to depreciation on leasehold land and plant and equipment which does not have an impact on the restated profit for the year ended 31 March 2019 due to transition to Ind AS 116 and therefore, does not form part of above reconciliation.

# INR 0.12 Mn relates to Interest and finance charges on lease liabilities relating to the leasehold plant & equipment, referred above, which does not have an impact on the restated profit for the year ended 31 March 2019 due to transition to Ind AS 116 and therefore, does not form part of above reconciliation.

## On account of reversal of rental expenses for which right-of-use assets have been recognised.

**Notes to adjustments:**

I) The lease standard i.e., Ind AS 116 has been notified to be effective for Audited Consolidated Financial Statements w.e.f 1 April 2019 which prescribes the accounting of the lease contracts entered in the capacity of a lessee and a lessor. The group has applied Ind AS 116 as of 1 April 2019 for preparing the Audited Consolidated Financial Statements for the period beginning from 1 April 2019. For the purpose of preparing Restated Consolidated Financial Information, Ind AS 116 has been applied retrospectively w.e.f. 1 April 2018.

Effective 1 April 2018, the group has recognised lease liability measured at an amount equal to present value of remaining lease payments and corresponding Right-of-use assets is measured at an amount equivalent to lease liability adjusted by the amount of any prepaid or accrued lease payments relating to that lease recognised in the balance sheet immediately before 1 April 2018.

II) Audit qualifications - Audit qualifications in auditor's report for the three months period ended 30 June 2021 does not require adjustments in Restated Consolidated Financial Information. Further, there are no audit qualifications in auditor's report for the financial years ended 31 March 2021, 31 March 2020 and 31 March 2019.

III) Material regrouping/ reclassification - Appropriate regrouping/ reclassification have been made in the Restated Consolidated Statement of Assets and Liabilities, Restated Consolidated Statement of Profit and Loss and Restated Consolidated Statement of Cash Flows, wherever required, by reclassification of the corresponding items of income, expenses, assets, liabilities and cash flows, in order to bring them in line with the accounting policies and classification as per the Audited Special Purpose Interim Consolidated Financial Statements for the three months period ended 30 June 2021 prepared in accordance with Schedule III (Division II) of the Act, requirements of Ind AS 1 - 'Presentation of financial statements' and other applicable Ind AS principles and the requirements of the Securities and Exchange Board of India (Issue of Capital and Disclosure Requirements) Regulations, 2018, as amended.

IV) Material errors - There were no material errors in Audited Special Purpose Interim Consolidated Financial Statements for the three months period ended 30 June 2021 and Audited Consolidated Financial Statements for the financial years ended 31 March 2021, 31 March 2020 and 31 March 2019 requiring any adjustments in Restated Consolidated Financial Information.

**Part B: Reconciliation of Retained Earnings and Foreign Currency Translation Reserve as per Audited Consolidated Financial Statements with Retained Earnings and Foreign Currency Translation Reserve as per Restated Consolidated Financial Information as at 31 March 2019**

The Group has followed the same accounting policy choices (transition options as per Ind AS 116) as at 1 April 2018 as adopted on 1 April 2019 for transition to Ind AS 116, while preparing the Restated Consolidated Financial Information. As specified in the Guidance Note, the Retained Earnings and Foreign Currency Translation Reserve balance computed under Restated Consolidated Financial Information as at 31 March 2019 and Retained Earnings and Foreign Currency Translation Reserve balance computed on transition (using modified retrospective approach) to Ind AS 116 as at 1 April 2019, differs due to restatement adjustments made for the year ended 31 March 2019. Accordingly, the closing Retained Earnings and Foreign Currency Translation Reserve balance as at 31 March 2019 of the Restated Consolidated Financial Information has not been carried forward to Restated Consolidated Statement of Asset and Liabilities as at 1 April 2019. The reconciliation of the same is as follows :

Particulars	31 March 2019
<b>Other Equity</b>	
<b>A. Retained earnings</b>	
Balance as at 31 March 2019 as per Restated Consolidated Financial Information	2,180.69
Add: Adjustment on account of transition to Ind AS 116	9.66
<b>Balance as at 1 April 2019 as per Audited Consolidated Financial Statements and Restated Consolidated Financial Information for the year ended 31 March 2020</b>	<b>2,190.35</b>
<b>B. Foreign Currency Translation Reserve</b>	
Balance as at 31 March 2019 as per Restated Consolidated Financial Information	(73.13)
Add: Adjustment on account of transition to Ind AS 116	(0.20)
<b>Balance as at 1 April 2019 as per Audited Consolidated Financial Statements and Restated Consolidated Financial Information for the year ended 31 March 2020</b>	<b>(73.33)</b>

**Part C: Non adjusting items**

**a) Emphasis of matter not requiring adjustments to Restated Consolidated Financial Information as given in the Independent Auditor's Examination Report dated 10 November 2021 on Restated Consolidated Financial Information:**

We draw your attention to the following:

"(i) Note 49 to the Restated Consolidated Financial Information regarding the accounting treatment of certain equity shares and compulsorily convertible participatory preference shares ("CCPP") presented as equity share capital and preference share capital respectively and the premium thereon presented under securities premium account in the Restated Consolidated Financial Information, in accordance with the requirements of the Companies Act, 2013. Such presentation and measurement is not in accordance with Ind AS 32 'Financial Instruments: Presentation' and Ind AS 109 'Financial Instruments' which requires the presentation of these equity shares, CCPP and the securities premium as a financial liability in its entirety, given the obligation on the Holding Company to buy-back these equity shares and CCPP from the holders and subsequent changes in measurement of financial liability to be recognised in the Restated Consolidated Statement of Profit and Loss. Further, the relevant disclosures required under Ind AS 107 'Financial Instruments: Disclosures' and under Ind AS 1 'Presentation of financial statements' for these equity shares and CCPP have not been made in the Restated Consolidated Financial Information in view of the reasons set out in the aforesaid Note. Our opinion is not modified in respect of this matter.

Note 49 referred above corresponds to Note 47 in the Special Purpose Interim Consolidated Financial Statements for the three months period ended June 30, 2021 and Note 49 in the Consolidated Financial Statements for the year ended March 31, 2021 and the above emphasis of matter paragraph has also been included in the auditor's report dated November 10, 2021 and auditor's report dated August 3, 2021 issued by us on the said Special Purpose Interim Consolidated Financial Statements of the company for the three months period ended June 30, 2021 and Consolidated Financial Statements of the company for the year ended March 31, 2021 respectively."

**b) Qualification not requiring adjustments to Restated Consolidated Financial Information as given in the Independent Auditor's Report dated 10 November 2021 on Special Purpose Interim Consolidated Financial Statement for the three months period ended 30 June 2021:**

**Basis for Qualified Opinion**

"We draw attention to Note 2.1 (i) to the Special Purpose Interim Consolidated Financial Statements in respect of non-disclosure of the comparative financial information, as the same is not considered relevant for the purpose for which these Special Purpose Interim Consolidated Financial Statements are prepared. This is not in compliance with the requirements of Ind AS 34, "Interim Financial Reporting". The impact of this non-compliance on the Special Purpose Interim Consolidated Financial Statements is presently not ascertainable.

**Qualified Opinion**

Based on our audit we report that, in our opinion and to the best of our information and according to the explanations given to us, except for the indeterminate effects of the matter described in the Basis for Qualified Opinion paragraph above, the Special Purpose Interim Consolidated Financial Statements, together with the notes thereon and attached thereto, fairly present, in all material respects, in conformity with the accounting principles generally accepted in India:

- (i) in the case of the Consolidated Balance Sheet, the state of affairs of the Group and its joint venture as at June 30, 2021;
- (ii) in the case of the Consolidated Statement of Profit and Loss, the total comprehensive income (comprising of profit and other comprehensive income) for the three months ended on that date;
- (iii) in the case of the Consolidated Statement of Changes in Equity, of the changes in equity for the three months ended on that date; and
- (iv) in the case of the Consolidated Statement of Cash Flows, of the cash flows for the three months ended on that date."

The above qualification doesn't require adjustments in the Restated Consolidated Financial Information as per the option available to the Issuer under para 11 (I) (A) (i) of the SEBI ICDR Regulations.

**c) Emphasis of matters not requiring adjustments to the Restated Consolidated Financial Information are reproduced below in respect of the Special Purpose Interim Consolidated Financial Statement for the three months period ended 30 June 2021 and the Audited Consolidated Financial Statements for the years ended 31 March 2020 and 31 March 2019:**

**1. Emphasis of Matters for the three months period ended 30 June 2021**

a) The following emphasis of matter paragraph has been included in the auditor's report dated November 10, 2021 on the Special Purpose Interim Consolidated Financial Statements for the three months period ended 30 June 2021:

"We draw your attention to Note 51 (d) to the Special Purpose Interim Consolidated Financial Statements regarding non-settlement of foreign currency payables as at June 30, 2021 amounting to INR 5.84 million and INR 0.47 million outstanding beyond the time period permitted under the Master Direction on Import of Goods and Services vide FED Master Direction No. 17/2016-17 dated January 1, 2016 (as amended), issued by the Reserve Bank of India (RBI), with respect to Merchanting Trade Transaction (MTT) and other import dues respectively. The holding company has submitted application to AD bank seeking RBI approval for extension of time for making payment for aforesaid foreign currency payables other than amount outstanding with respect to MTT, for which approval for making payment has been sought. Our opinion is not modified in respect of this matter."

**2. Emphasis of Matters for the year ended 31 March 2020**

a) The following emphasis of matter paragraph has been included in the auditor's report dated September 18, 2020 on the Consolidated Financial Statements for the year ended March 31, 2020:

"We draw your attention to emphasis of matter paragraph included in the Audit Report on the Consolidated Financial Statements of Tega Industries Chile SpA, a stepdown subsidiary of the Holding Company issued by an independent firm of Chartered Accountants vide its report dated August 26, 2020.

"As of March 31, 2020, the Parent Company presents a deferred tax asset for TH\$ 2,273,885 arising from accumulated tax losses. Its recoverability will depend on compliance with the respective business plan prepared by Management and approved by the Board of Directors of the Company, which is described in Note 21.

As described in Note 26 to the accompanying consolidated financial statements, the Company has recorded negative working capital for TH\$ 1,840,539 (TH\$ 4,567,385 in 2019). Our opinion is not modified with respect to this matter".

Note 21 and 26 above has been reproduced by the Management vide Note 47 in the notes to the consolidated financial statements. The Parent Company mentioned above is Tega Industries Chile SpA. Our opinion is not modified in respect of this matter."

**3. Emphasis of Matters for the year ended 31 March 2019**

a) The following emphasis of matter paragraph has been included in the auditor's report dated August 13, 2019 on the Consolidated Financial Statements for the year ended March 31, 2019:

"We draw your attention to the emphasis of matter paragraph included in the Audit Report on the Consolidated Financial Statements of Tega Industries Chile, SPA, a subsidiary of the Holding Company issued by an independent firm of Chartered Accountants vide its report dated June 26, 2019.

"The accompanying financial statements have been prepared assuming that the Company will continue as a going concern. As described in Note No. 18 to the accompanying consolidated financial statements, the Company has recorded negative working capital for M\$ 4,567,385 (M\$ 5,829,639 in 2018), and presents equity deficit in both periods, which introduces a significant doubt about the ability of the Company to continue as a going concern. Management's plan on this matter is also described in Note No. 18. The accompanying Consolidated Financial Statements include no adjustment that might lead to the resolution of the uncertainty expressed above."

Note 18 referred to above have been reproduced by the Management vide Note 50 in the notes to the Consolidated Financial Statements. Our opinion is not modified in respect of this matter."

**d) Auditor's Comments in Annexure to Auditors' Report:**

In addition to the audit opinion on the consolidated financial statements, the auditors are required to comment upon the matters included in the Companies (Auditor's Report) Order, 2016 ("the CARO 2016 Order") issued by the Central Government of India under sub-section (11) of Section 143 of Companies Act, 2013 on the standalone financial statements as at and for the financial years ended 31 March 2021, 31 March 2020 and 31 March 2019 respectively. Certain statements/ comments included in the CARO in the standalone financial statements, which do not require any adjustments in the Restated Consolidated Financial Information are reproduced below in respect of the financial statements presented. The information presented below is for the Holding Company and its joint venture whose audited financial statements are forming part of consolidated financial statements for each of the respective years.

**i) Tega Industries Limited (Holding Company)**

**Financial Year 2020-21**

**Clause vii(a) of CARO 2016 Order**

According to the information and explanations given to us and the records of the Company examined by us, in our opinion, the Company is regular in depositing the undisputed statutory dues, including provident fund, employees' state insurance, income tax, sales tax, service tax, duty of customs, duty of excise, value added tax, cess, goods and service tax and other material statutory dues, as applicable, with the appropriate authorities. Also refer note 42C to the Standalone Financial Statements regarding management's assessment on certain matters relating to provident fund.

**Clause vii(b) of CARO 2016 Order**

According to the information and explanations given to us and the records of the Company examined by us, there are no dues of goods and service tax as at March 31, 2021 which have not been deposited on account of any dispute. The particulars of dues of income tax, sales tax, service tax, duty of excise and value added tax as at March 31, 2021 which have not been deposited on account of a dispute, are as follows:

Name of the Statute	Nature of Dues	Amount (INR In millions)	Period to which amount relates	Forum where dispute is pending
Central Excise Act, 1994	Excise Duty	9.51	2006-07, 2007-08, 2008-09, 2009-10, 2010-11, 2011-12	CESTAT
Finance Act, 1994	Service Tax	0.58	2013-14	CESTAT
		0.34	2007-08	Commissioner (Appeals)
Income Tax Act, 1961	Income Tax	0.87	AY 2008-09	Assessing Officer
		123.66	AY 2003-04, AY 2016-17, AY 2018-19	Commissioner of Income Tax (Appeals)
		4.89	AY 2014-15, AY 2015-16	Income Tax Appellate Tribunal
		0.03	1995-96	Appellate and Revisional Board
Central Sales Tax Act, 1956	Declaration form due, Disallowances	1.10	2016-17	Sr. Joint Commissioner of Commercial Taxes (Appeals)
		0.65	2017-18	Deputy Commissioner of Commercial Tax
		5.35	2003-04, 2004-05, 2006-07	High Court at Kolkata
		1.08	2013-14, 2017-18	Deputy Commissioner of Commercial Tax
West Bengal Value Added Tax Act, 2003	VAT Liability, Disallowances	3.74	2016-17	Sr. Joint Commissioner of Commercial Taxes (Appeals)
		0.71	2003-04, 2004-05	High Court at Kolkata
		3.06	2016-17, 2017-18, 2018-19	Commissioner of Customs (Appeals) (Subsequently filed on July 20, 2021)
Customs Act, 1962	Custom Duty	3.06	2016-17, 2017-18, 2018-19	Commissioner of Customs (Appeals) (Subsequently filed on July 20, 2021)

**Financial Year 2019-20**

**Clause i(c) of CARO 2016 Order**

The title deeds of immovable properties, as disclosed in Note 3 (a) on property, plant and equipment to the Standalone Financial Statements, are held in the name of the Company except for cases below:

Asset Category	Gross Block as at March 31, 2020 (Rs. in millions)	Net Block as at March 31, 2020 (Rs. in millions)	Remarks
Freehold Land	4.40	4.40	Title deed pending to be transferred in the name of the Company
Freehold Buildings	3.38	3.00	Title deed pending to be transferred in the name of the Company

**Clause vii(a) of CARO 2016 Order**

According to the information and explanations given to us and the records of the Company examined by us, in our opinion, the Company is regular in depositing undisputed statutory dues, including provident fund, employee's state insurance, income tax, sales tax, service tax, duty of customs, duty of excise, value added tax, cess, goods and service tax and other material statutory dues, as applicable, with the appropriate authorities. Also refer note 41(c) to the standalone financial statements regarding management's assessment on certain matters relating to provident fund.

**Clause vii(b) of CARO 2016 Order**

According to the information and explanations given to us and the records of the Company examined by us, there are no dues of goods and service tax as at March 31, 2020 which have not been deposited on account of any dispute. The particulars of dues of income tax, sales tax, service tax, duty of excise and value added tax as at March 31, 2020 which have not been deposited on account of a dispute, are as follows:

Name of the Statute	Nature of Dues	Amount (Rs. in millions)	Period to which amount relates	Forum where dispute is pending
Central Excise Act, 1994	Excise Duty	9.51	2006-07, 2007-08, 2008-09, 2009-10, 2010-11, 2011-12	CESTAT
Finance Act, 1994	Service Tax	0.58	2013-14	CESTAT
		0.34	2007-08	Commissioner (Appeals)
Income Tax Act, 1961	Income Tax	0.87	AY 2008-09	Assessing Officer
		5.82	AY 2003-04, AY 2016-17	Commissioner of Income Tax (Appeals)
		4.89	AY 2014-15, AY 2015-16	Income Tax Appellate Tribunal
Central Sales Tax Act, 1956	Declaration form due, Disallowances	4.73	1995-96, 2015-16	Appellate and Revisional Board
		2.30	2012-13, 2016-17	Sr. Joint Commissioner of Commercial Taxes (Appeals)
		0.65	2017-18	Deputy Commissioner of Commercial Tax
		6.03	2003-04, 2004-05, 2006-07	High Court at Kolkata
West Bengal Value Added Tax Act, 2003	VAT Liability, Disallowances	0.24	2016-17	Appellate and Revisional Board
		1.08	2013-14, 2017-18	Deputy Commissioner of Commercial Tax
		3.77	2012-13, 2016-17	Sr. Joint Commissioner of Commercial Taxes (Appeals)
		0.75	2003-04, 2004-05	High Court at Kolkata

**Financial Year 2018-19**

**Clause i(c) of CARO 2016 Order**

The title deeds of immovable properties, as disclosed in Note 3 (a) on fixed assets to the Standalone Financial Statements, are held in the name of the Company except for cases below:

Asset Category	Gross Block as at March 31, 2019 (Rs. in millions)	Net Block as at March 31, 2019 (Rs. in millions)	Remarks
Freehold Land	4.40	4.40	Title deed pending to be transferred in the name of the Company
Freehold Buildings	3.38	3.05	Title deed pending to be transferred in the name of the Company

**Clause vii(a) of CARO 2016 Order**

According to the information and explanations given to us and the records of the Company examined by us, in our opinion, the Company is generally regular in depositing undisputed statutory dues in respect of income tax, provident fund and employees' state insurance, though there has been a slight delay in a few cases, and is regular in depositing undisputed statutory dues, including, sales tax, service tax, duty of customs, duty of excise, value added tax, cess, goods and service tax and other material statutory dues, as applicable, with the appropriate authorities. Also refer note 44(c) to the Standalone Financial Statements regarding management's assessment on certain matters relating to provident fund.

**Clause vii(b) of CARO 2016 Order**

According to the information and explanations given to us and the records of the Company examined by us, there are no dues of goods and service tax as at March 31, 2019 which have not been deposited on account of any dispute. The particulars of dues of income tax, sales tax, service tax, duty of excise and value added tax as at March 31, 2019 which have not been deposited on account of a dispute, are as follows:

Name of the Statute	Nature of Dues	Amount (Rs. in millions)	Period to which amount relates	Forum where dispute is pending
Central Excise Act, 1994	Excise Duty	17.86	2006-07, 2007-08, 2008-09, 2009-10, 2010-11, 2011-12, 2012-13, 2013-14, 2014-15, 2015-16	CESTAT
		2.20	2012-13, 2013-14, 2014-15, 2015-16, 2016-17	Commissioner (Appeals)
Finance Act, 1994	Service Tax	3.46	2009-10, 2013-14	CESTAT
		0.44	2007-08, 2012-13	Commissioner (Appeals)
Income Tax Act, 1961	Income Tax	0.87	AY 2008-09	Assessing Officer
		0.70	AY 1993-94, AY 2003-04	Commissioner of Income Tax (Appeals)
		39.71	AY 2007-08, AY 2009-10, AY 2010-11, AY 2011-12, AY 2012-13, AY 2013-14, AY 2014-15	Income Tax Appellate Tribunal
Central Sales Tax Act, 1956	Declaration form due, Disallowances	4.73	1995-96, 2015-16	Appellate and Revisional Board
		18.12	2012-13	Sr. Joint Commissioner of Commercial Taxes (Appeals)
		2.01	2016-17	Deputy Commissioner of Commercial Tax
		6.03	2003-04, 2004-05, 2006-07	High Court at Kolkata
West Bengal Value Added Tax Act, 2003	VAT Liability, Disallowances	0.24	2016-17	Appellate and Revisional Board
		1.92	2013-14, 2016-17	Deputy Commissioner of Commercial Tax
		0.75	2003-04, 2004-05	High Court at Kolkata

ii) Hosch Equipment (India) Limited (Joint Venture)

**Financial Year 2020-21**

**Clause vii(a) of CARO 2016 Order**

According to the information and explanations given to us and the records of the Company examined by us, in our opinion, the Company is regular in depositing the undisputed statutory dues, including provident fund, employees' state insurance, income tax, sales tax, service tax, duty of customs, duty of excise, value added tax, cess, goods and service tax and other material statutory dues, as applicable, with the appropriate authorities. Also refer note 35(b) to the financial statements regarding management's assessment on certain matters relating to provident fund.

**Clause vii(b) of CARO 2016 Order**

According to the information and explanations given to us and the records of the Company examined by us, there are no dues of service-tax, duty of customs and goods and service tax which have not been deposited on account of any dispute. The particulars of dues of income tax, sales tax, duty of excise and value added tax as at March 31, 2021 which have not been deposited on account of a dispute, are as follows:

Name of the Statute	Nature of Dues	Amount (Rs. in thousands)	Period to which amount relates	Forum where dispute is pending
Central Excise Act, 1994	Excise Duty	31,262.59	2007-08 to 2011-12	CESTAT
Central Sales Tax Act, 1956	Declaration form due, disallowances	313.74	2002-03	Appellate and revisional Board
		428.16	2004-05	Appellate and revisional Board
West Bengal Value Added Tax Act, 2003	VAT Liability, Disallowances	40.54	2003-04	Appellate and revisional Board
		228.41	2004-05	Appellate and revisional Board
		1.05	2009-10	Joint Commissioner of Commercial Taxes
Income Tax Act, 1961	Income Tax	1,003.54	AY 2014-15	Income Tax Appellate Tribunal
		144.80	AY 2018-19	Commissioner of Income Tax (Appeals)

**Financial Year 2019-20**

**Clause vii(a) of CARO 2016 Order**

According to the information and explanations given to us and the records of the Company examined by us, in our opinion, the Company is regular in depositing the undisputed statutory dues, including provident fund, employees' state insurance, income tax, sales tax, service tax, duty of customs, duty of excise, value added tax, cess, goods and service tax and other material statutory dues, as applicable, with the appropriate authorities. Also refer note 36(b) to the financial statements regarding management's assessment on certain matters relating to provident fund.

**Clause vii(b) of CARO 2016 Order**

According to the information and explanations given to us and the records of the Company examined by us, there are no dues of service-tax, duty of customs and goods and service tax which have not been deposited on account of any dispute. The particulars of dues of income tax, sales tax, duty of excise and value added tax as at March 31, 2020 which have not been deposited on account of a dispute, are as follows:

Name of Statute	Nature of dues	Amount (Rs. in thousands)	Period to which the amount relates	Forum where the dispute is pending
Central Excise Act, 1944	Excise Duty	31,262.59	2007-08 to 2011-12	CESTAT
Central State Tax Act, 1956	Declaration form due, Disallowances	313.74	2002-03	Appellate and revisional Board
		575.37	2004-05	Appellate and revisional Board
		980.96	2015-16, 2016-17, 2017-18	Joint Commissioner of Commercial Taxes
West Bengal Value Added Tax Act, 2003	VAT Liability, Disallowances	40.54	2003-04	Appellate and revisional Board
		228.41	2004-05	Appellate and revisional Board
		1.05	2009-10	Joint Commissioner of Commercial Taxes
Income Tax Act, 1961	Income Tax	1,148.34	AY 2014-15, 2018-19	Commissioner of Income Tax (Appeals)

**Financial Year 2018-19**

**Clause vii(a) of CARO 2016 Order**

According to information and explanation given to us and as per the records of the Company examined by us, the Company is generally regular in depositing with appropriate authorities undisputed statutory dues including provident fund, employees' state insurance, income-tax, sales tax, service tax, duty of custom, duty of excise, value added tax, goods & service tax, cess and other statutory dues applicable to it. No undisputed amount of statutory dues were outstanding, as at 31st March 2019 for a period of more than six months from the date they became payable.

**Clause vii(b) of CARO 2016 Order**

According to information and explanations given to us and the records of the Company examined by us, there are no dues of income tax, sales tax, service tax, custom duty, excise duty, value added tax and goods & service tax as on 31st March, 2019 which have not been deposited on account of any dispute other than the following :

Under West Bengal VAT Act, 2003				
Period	Tax Assessed including penalty (INR)*	Tax Admitted (INR)*	Dispute (INR)*	Remarks
2009-10	1,047	NIL	1,047	Case lying with Dy commissioner of –Commercial Taxes, Alipore charge.
2010 - 11	123,120	25,220	97,900	Revision filed before The West Bengal Commissioner Tax Appeal & Revision Board.
Under CST Act, 1956				
2002 - 03	562,485	248,744	313,741	Revision filed before The Honourable President West Bengal Commercial Taxes Appellate & Revision Board.
2004 - 05	2,732,811	2,157,443	575,368	Revision filed before The Honourable President West Bengal Commercial Taxes Appellate & Revision Board.
2010-11	2,452,866	801,463	1,651,403	SOD applied and paid
2011-12	3,360,809	1,249,182	2,111,627	SOD applied and paid.
2012-13	2,642,455	941,391	1,701,064	SOD applied and paid.
2013-14	3,117,668	428,304	2,689,364	SOD applied and paid.
Under Central Excise Act, 1944				
Anti-Evasion case	32,762,594 Including penalty	1,500,000	31,262,594	Demand confirmed by Commissioner of Central Excise, Kol-VII, Appeal to Tribunal under process. Rs. 15,00L deposited as per order of Tribunal.
Anti-Evasion case	53,858	4,042	49,816	Appeal Filled before Commissioner (Appeals).
Under Income Tax Act, 1961				
AY 2014-15	20,11,726	Nil	20,11,726	Appeal filed before the Commissioner of Income Tax –Appeal.

\* Amount in absolute figures

**For Price Waterhouse & Co Bangalore LLP**

Firm Registration Number: 0075678/S-200012  
Chartered Accountants

Avijit Mukerji  
Partner  
Membership Number: 056155

Place : Kolkata  
Date : 10 November 2021

**For and on behalf of Board of Directors**

Madan Mohan Mohanka  
Chairman  
DIN: 00049388

Mehul Mohanka  
Managing Director  
DIN: 00052134

Sudipta Bhowal  
Company Secretary

Place : Kolkata  
Date : 10 November 2021

Manoj Kumar Agarwal  
Chief Financial Officer

## OTHER FINANCIAL INFORMATION

The audited standalone financial statements of our Company and our Material Subsidiaries as at and for the year ended March 31, 2021, March 31, 2020, and March 31, 2019 and the reports thereon dated, as mentioned below, (the “**Audited Financial Statements**”) are available at [www.tegaindustries.com/investorrelations/](http://www.tegaindustries.com/investorrelations/).

Entity	As at and for March 31, 2021	As at and for March 31, 2020	As at and for March 31, 2019
Company	August 3, 2021	September 18, 2020	August 13, 2019
Tega Africa	May 13, 2021	July 14, 2020	August 12, 2019
Tega Chile	May 20, 2021	August 26, 2020	July 26, 2019
Tega Holdings Pte Ltd	July 21, 2021	September 18, 2020	August 13, 2019
Losugen	May 19, 2021	July 9, 2020	August 8, 2019

Our Company is providing a link to this website solely to comply with the requirements specified in the SEBI ICDR Regulations. The Audited Financial Statements do not constitute, (i) a part of this Red Herring Prospectus; or (ii) a prospectus, a statement in lieu of a prospectus, an offering circular, an offering memorandum, an advertisement, an offer or a solicitation of any offer or an offer document to purchase or sell any securities under the Companies Act 2013, the SEBI ICDR Regulations, or any other applicable law in India or elsewhere in the world. The Audited Financial Statements should not be considered as part of information that any investor should consider to subscribe for or purchase any securities of our Company, or any entity in which it or its shareholders have significant influence and should not be relied upon or used as a basis for any investment decision. Due caution is advised when accessing and placing reliance on any historic or other information available in the public domain. None of the BRLMs or the Selling Shareholders, nor any of their respective employees, directors, affiliates, agents or representatives accept any liability whatsoever for any loss, direct or indirect, arising from any reliance being made for any investment decision, on any information presented or contained in the Audited Financial Statements, or the opinions expressed therein.

Set forth below are the details of accounting ratios as at June 30, 2021, March 31, 2021, March 31, 2020 and March 31, 2019 calculated on the of basis Restated Consolidated Financial Information:

<i>(in ₹ million, except otherwise stated)</i>				
Particulars	June 30, 2021	March 31, 2021	March 31, 2020	March 31, 2019
<b>Restated earnings per Equity Share<sup>#</sup></b>				
Basic	2.10	24.10	11.57	5.76
Diluted	1.78	20.48	9.84	4.90
<b>Return on Net Worth %<sup>*</sup></b>	1.88	22.23	14.16	8.14
Net asset value per share <sup>^</sup>	108.06	105.04	78.78	68.13
- Weighted average number of equity shares for Basic	56,601,259	56,601,259	56,601,259	56,601,259
- Weighted average number of equity shares for Dilutive	66,596,337	66,594,043	66,562,303	66,570,780
Earnings before finance cost, depreciation, amortisation, tax and exceptional items (EBITDA <sup>***</sup> )	296.79	2,386.42	1,172.28	1,060.03
Restated total profit for the period/ year <sup>#</sup>	118.82	1,364.05	655.04	326.70
Equity share capital <sup>#</sup>	576.01	576.01	576.01	576.01
Preference share capital <sup>#</sup>	86.92	86.92	86.92	86.92
Other equity <sup>#</sup>	5,648.59	5,474.29	3,961.96	3,348.12
Non-controlling interest <sup>###</sup>	0.00	0.00	0.00	0.00
Net worth	6,311.52	6,137.22	4,624.89	4,011.05

<sup>^</sup> Net Asset Value per equity share represents net worth attributable to Equity Shareholder (Equity Share capital together with other equity as per Restated Consolidated Financial Information) as at the end of the period/ fiscal year divided by the number of Equity Shares outstanding at the end of the year

<sup>\*</sup> Return on Net Worth (%) = Restated profit for the year/ period attributable to equity shareholders of the Company divided by net worth.

<sup>\*\*</sup> Amount is below the rounding off norms adopted by the Group

<sup>\*\*\*</sup> EBITDA means the restated profit before share of restated net profit of joint venture accounted for using equity method and tax, finance costs, depreciation and amortisation expenses

<sup>#</sup> Based on Restated Consolidated Financial Information



## FINANCIAL INDEBTEDNESS

Pursuant to our Articles of Association, subject to applicable laws and pursuant to the Board resolution dated August 22, 2014 and the special resolution passed by our Shareholders on September 29, 2014, our Board has been authorised to borrow sums of money for or on behalf of the Company, from time to time, from any persons, firms, bodies corporate, bankers, financial institutions or from other ways of advances, deposits, loans or otherwise and whether unsecured or secured by mortgage, charge, hypothecation or lien or pledge on the Company's assets, whether moveable or immovable, so borrowed together with moneys, if any, already borrowed by the Company (apart from temporary loans obtained from the Company's bankers in the ordinary course of business) will or may exceed the aggregate of the paid capital of the Company and its free reserves which have not been set apart for any specific purposes, provided that the total amount up to which the moneys can be borrowed whether in foreign currency and/or Indian National Rupees, in whatever manner, for a sum not exceeding ₹ 5,000 million, together with interest, compound interest, accumulated interest, liquidated damages, commitment charges, and such other costs, charges, expenses, and other monies payable by the Company in terms of loans and any other documents entered into between the Company and the lenders, agents, financial/investment institutions, banks, trustees, in respect to of the said loans/borrowings/debentures and containing such terms and conditions and covenants in respect of enforcement of security as may be stipulated in that behalf and agreed to between the Board and the lenders, agents, financial/investment institutions, banks and trustees.

The details of aggregate indebtedness of our Company and our Subsidiaries as on September 30, 2021 is set forth below:

Category of borrowing	Sanctioned amount	Outstanding amount as on September 30 2021 <sup>#</sup>
<i>(in ₹ million, unless otherwise specified)</i>		
<b>Secured</b>		
Term loans	1,242.46	945.87
Working capital facilities		
- Fund based <sup>(1)</sup>	2,118.13	793.54
- Non-fund based <sup>(2)</sup>	817.86	1,084.96
<b>Unsecured</b>		
Term Loans	58.73	43.35
<b>Total</b>	<b>4,237.18</b>	<b>2,867.72</b>

Note: The exchange rates as of September 30, 2021 for the relevant currencies are i) USD = ₹74.23 (Source: FEDAI), ii) CAD = ₹58.33 (Source: FEDAI), iii) CLP = ₹0.09205 (Source: Oanda), iv) ZAR = ₹4.90 (Source: FEDAI), and v) UF= ₹30,088.37 CLP (Source: Central Bank of Chile)

<sup>\*</sup>As certified by SDT & Co, Chartered Accountants, by way of their certificate dated November 10, 2021

<sup>#</sup>Includes the vehicle loans availed by our Company as on September 30, 2021

<sup>(1)</sup> Out of this amount ₹1,770 million has interchangeability between fund to non-fund base.

<sup>(2)</sup>For the facility from ACF Capital to Tega Industries Chile SpA sanction limit is not ascertainable. As per terms of sanction it is upto the discretion of the ACF Capital for sanctioning limit for the acceptance of the factoring which will be decided on contract to contract basis. Hence, utilized amount of Rs. 60.13 million is consider as sanctioned amount above.

### Principal terms of the borrowings availed of by our Company and our Subsidiaries

Set out below are the principal terms of the borrowing availed of by us:

**Interest:** In terms of the foreign currency denominated term loans availed by us, interest rate is typically tied to the USD LIBOR. In terms of the working capital facilities availed by us, the interest rate is typically tied to MCLR and spread, with varying reset options. For certain working capital facilities, the interest rates are subject to the extant RBI guidelines on trade credit.

**Tenor:** The tenor of the term loan facilities typically ranges from sixty to eighty-four months. The tenor of the working capital facilities typically ranges from seven days to twelve months. The bank guarantees may extend up to three years.

**Security:** In terms of our borrowings where security needs to be created, such security typically includes:

- a) Charge by way of mortgage on the fixed assets of the Company (both moveable and immovable);
- b) Charge by way of hypothecation on the entire current assets of the Company;
- c) Charge on the encumbered cash and cash equivalents of minimum reserve amounts, as may be determined by the lenders; and

- d) Pledge of units of certain mutual funds held by the Company.

In terms of the working capital borrowings of our Subsidiaries, where security needs to be created, such security typically includes:

- a) Charge by way of an assignment or security cession of all present and future debts of the Subsidiaries; and
- b) Charge by way of an assignment or security cession of the insurance policies held in favour of the Subsidiaries.

This is an indicative list and there may be additional requirements for creation of security under the various borrowing arrangements entered into by us.

**Re-payment:** The term loans are typically repayable in quarterly instalments. For working capital facilities, while the facilities are typically repayable on demand with an option for annual review for each of the sub-limits, there may exist certain exclusive provisions of repayment for each of the sub-limits, subject to the facility documentation for each lender.

**Prepayment:** The term loans and working capital facilities availed by us typically have prepayment provisions which allow for pre-payment of the outstanding loan amount subject to such prepayment penalties as may be decided by the lender at the time of such prepayment, or as laid down in the facility document, as the case may be. For certain working capital facilities, prepayment penalties may not be payable, subject to the conditions as specified in the facility documentation.

**Covenants:** Borrowing arrangements entered into by our Company for the term loans and working capital facilities entered into by us typically contain various restrictive conditions and covenants restricting certain corporate actions, and we are required to take the prior approval of the lender before carrying out such activities, including, among others, for:

- a) effect any change in the constitutional documents or management or capital structure of our Company;
- b) effect any change in the business of our Company;
- c) effect any reorganization, merger, amalgamation or scheme of arrangement or compromise;
- d) declare any dividend if any instalments towards principal amount or interest is unpaid after the due date
- e) changes in the shareholding pattern of the Company; and
- f) induct or continue with a person as a director or a promoter of our Company who has been identified as a wilful defaulter as per the RBI guidelines issued from time to time.

Borrowing arrangements entered into by our Subsidiaries for the term loans and working capital facilities entered into by them typically contain various restrictive conditions and covenants restricting certain corporate actions, and they are required to take the prior approval of the lender before carrying out such activities, including, among others, for:

- a) effect any change in the constitutional documents or management or capital structure of our Subsidiaries;
- b) effect any change in the business of our Subsidiaries; and
- c) effect any reorganization, merger, amalgamation or scheme of arrangement or compromise.

**Events of Default:** Borrowing arrangements entered into by us for the term loans and working capital loans contain standard events of default, including:

- a) non-payment or default of principal and/or interest due on the loan obligation by our Company and our Subsidiaries;
- b) breach of any covenant, condition, agreement or any other conditions by our Company and our Subsidiaries;

- c) proceedings relating to winding up, insolvency being initiated against our Company and our Subsidiaries;
- d) failure in business, commission of an act of bankruptcy and general assignment for the benefit of the creditors;
- e) if our Company and our Subsidiaries undergo any material adverse change, as may be determined by our Company.

This is an indicative list and there may be additional terms that may amount to an event of default under the various borrowing arrangements entered into by us.

## CAPITALIZATION STATEMENT

The following table sets forth our Company's capitalization as on June 30, 2021, on the basis of our Restated Consolidated Financial Information, and as adjusted for the Offer. This table should be read in conjunction with the sections titled "*Risk Factors*", "*Financial Information*" and "*Management's Discussion and Analysis of Financial Condition and Results of Operations*" on pages 23, 207 and 318, respectively.

<i>(in ₹ million)</i>		
Particulars	Pre-Offer as on June 30, 2021	As adjusted for the proposed Offer*
<b>Debt</b>		
Current borrowings	797.17	[•]
Non-current borrowings (including current maturities)	1,045.21	[•]
<b>Total Debt (A)</b>	1,842.38	[•]
<b>Shareholders' Funds</b>		
Equity share capital	576.01	[•]
Preference share capital	86.92	[•]
Other equity	5,648.59	[•]
<b>Total Shareholders' Funds (B)</b>	6,311.52	[•]
<b>Ratio: Non-current borrowings (including current maturities) / Total Equity</b>	0.17	[•]
<b>Ratio: Total Debt (A)/ Total Equity (B)</b>	0.29	[•]

\*The corresponding post-Offer capitalization data for each of the amounts given in the above table is not determinable at this stage pending the completion of the book building process and hence, the same have not been provided in the above statement.

Notes:

(1) Pursuant to resolutions dated November 10, 2021 passed by our Board and Shareholders, 8,692,281 CCPP held by Wagner Limited were converted to 8,692,281 Equity Shares. The above statement is not adjusted to effect the conversion.

## MANAGEMENT'S DISCUSSION AND ANALYSIS OF FINANCIAL CONDITION AND RESULTS OF OPERATIONS

*You should read the following discussion and analysis of our financial condition and results of operations, and our assessment of the factors that may affect our prospects and performance in future periods, together with our Restated Consolidated Financial Information, including the reports thereon, each included in this Red Herring Prospectus.*

*The Restated Consolidated Financial Information are prepared and presented in accordance with Ind AS, in each case restated in accordance with the requirements of Section 26 of the Companies Act 2013, as amended, the SEBI ICDR Regulations and the Guidance Note on Reports in Company Prospectuses (Revised 2019) issued by the ICAI.*

*Ind AS differs in certain material respects from IFRS and U.S. GAAP. Accordingly, the degree to which our financial statements will provide meaningful information to a prospective investor in countries other than India is entirely dependent on the reader's level of familiarity with Ind AS. As a result, the Restated Consolidated Financial Information may not be comparable to our historical financial statements. Please also see "**Financial Information**" on page 207..*

*This discussion and analysis contains forward-looking statements that reflect our current views with respect to future events and our financial performance, which are subject to numerous risks and uncertainties. Our actual results may differ materially from those anticipated in these forward-looking statements. As such, you should also read "**Forward-Looking Statements**" and "**Risk Factors**" and beginning on pages 16 and 23, respectively, which discuss a number of factors and contingencies that could affect our financial condition and results of operations.*

*Unless otherwise indicated, industry and market data used in this section have been derived from the report titled "Global Market Assessment – Select Mineral Processing Equipment" dated October 12, 2021, issued by Frost & Sullivan (the "**F&S Report**") prepared and released by Frost & Sullivan and commissioned and paid for by our Company in connection with the Offer. Unless otherwise indicated, all financial, operational, industry and other related information derived from the F&S Report and included herein with respect to any particular year refers to such information for the relevant calendar year. Also see, "**Certain Conventions, Use of Financial Information and Market Data and Currency of Presentation – Industry and Market Data**" on page 13. Our fiscal year ends on March 31 of each year.*

### Overview

We are a leading manufacturer and distributor of specialized 'critical to operate' and recurring consumable products for the global mineral beneficiation, mining and bulk solids handling industry, on the basis of sales as of June 30, 2021 (*Source: F&S Report*). Globally, we are the second largest producers of polymer-based mill liners, on the basis of revenues as of June 30, 2021 (*Source: F&S Report*).

We offer comprehensive solutions to marquee global clients in the mineral beneficiation, mining and bulk solids handling industry, through our wide product portfolio of specialized abrasion and wear-resistant rubber, polyurethane, steel and ceramic based lining components, used by our customers across different stages of mining and mineral processing, screening, grinding and material handling, including after-market spends on wear, spare parts, grinding media and power, which are regular operating expenses for our customers. Our engineering capability, which has evolved over decades, has enabled us to consistently offer our quality, complex manufactured products within stipulated timelines, allowing us to reduce downtime and maximize operational efficiency for our customers, and forge robust relationships with our customers leading to high recurring revenues.

We commenced operations in 1978 in India, with a foreign collaboration with Skega AB, Sweden. Madan Mohan Mohanka acquired the entire equity stake of Skega AB in our Company in 2001. Our individual Promoters are Madan Mohan Mohanka, Manju Mohanka, Manish Mohanka and Mehul Mohanka. Our MD and CEO, Mehul Mohanka, has been involved in the Company's business for the last 18 years, and has led our business as our CEO for the last 5 years. In 2011, we received funding from Wagner Ltd., an entity affiliated with TA Associates, a global private equity firm.

Our product portfolio comprises of more than 55 mineral processing and material handling products. As an average (sum of Fiscal 2021, 2020 and 2019 divided by 3) of the last three Fiscals, i.e. 2021, 2020 and 2019, sale of products constitutes 95.08% of our revenue from operations, while our sale of services and other operating revenue constitutes 2.15% and 2.77%, respectively of our revenue from operations. For the three months period

ended June 30, 2021, the sale of products constitutes 94.56% of our revenue from operations, while the sale of services and other operating revenue constitutes 3.33% and 2.11%, respectively of our revenue from operations.

Our products offering include consumables required in the mines and mineral processing industry. In the sequence of their usage in the mineral processing value chain, after blasting to floatation, our products include chutes and its liners, grinding mill liners, trommels and screens, hydrocyclones, pumps and flotation parts and conveyor products. Our product range is engineered with a combination of mineral processing engineering, mechanical engineering and material sciences, while utilising our expertise in tribology.

We have a track-record of servicing leading global mining companies for a long period of time. Revenue from operation from outside India constituted 84.48%, 86.42%, 85.92% and 85.83% of our revenue from operations in the three months period ended June 30, 2021 and Fiscals 2021, 2020 and 2019, respectively. For the last three Fiscals, we have presence in 513, 498 and 479 installation sites in over 70 countries. Further, for the three months period ended June 30, 2021, we have presence in 212 installation sites. Revenue from operation from outside India include North America, South America, EMER (Europe, Middle East and Russia), Africa, and Asia Pacific (South East Asia and Australia) which constituted 17.66%, 19.23%, 14.18%, 21.18% and 12.23% of our revenue from operations for the three months period ended June 30, 2021 and 13.74%, 24.71%, 15.49%, 22.62% and 9.85% of our revenue from operations in Fiscal 2021. We are further expanding our operations in major markets including North America, South America, Australia (part of Asia Pacific) and South Africa. Our focus end-customers are mineral processing sites involved in gold and copper ore beneficiation, accounting for 34.92% and 27.25% respectively of our sale of products as an average of the last three Fiscals and 45.48% and 20.76% respectively of our sale of products for the three months period ended June 30, 2021. We have six manufacturing sites, including three in India, at Dahej in Gujarat and at Samali and Kalyani in West Bengal, and three sites in major mining hubs of Chile, South Africa and Australia, with a total built-up area of 74255 Sq. mts. Our facilities in India caters to the domestic and overseas markets across mineral processing and materials handling industries, while our facilities in Chile, South Africa and Australia caters to their respective local and regional mineral processing and materials handling industries. Additionally, our joint venture in India with U.K. branch of Hosch Group, Germany is engaged in precision conveyer belt cleaning and caters to various industries in India. We also have 18 global and 14 domestic sales offices located close to our key customers and mining sites.

With on-ground presence in all major mining locations, we are well positioned to cater to our customers across the world which comprise large global mining companies as well as small and medium size companies in the mining and mineral beneficiation industry in developed countries as well as in emerging regions.

In order to expand our operations globally, we acquired Tega Industries Africa (Pty) Ltd. (formerly, Beruc Equipment (Proprietary) Limited) (“**Tega Africa**”) in 2006 which is a South Africa based manufacturer and distributor of grinding mill liners and screen media, amongst others and this gave us access to manufacturing capabilities and customers in Africa’s mining and industrial markets. Our facilities in South Africa also give us access to the member countries of the Southern African Development Community (SADC). We continued our expansion and acquired Chile based Tega Industries Chile SpA (formerly Acotec SA) (“**Tega Chile**”) in 2011 which is involved in the manufacture of pumps, screen media and wear products. Our facilities in Chile give us access to the Latin American markets including Chile, Peru and Bolivia (According to the F&S Report, Latin American countries contribute 40% of the global copper production and 8% of the global gold production output). In 2010, we also acquired Perth based Losugen Pty. Ltd. (“**Losugen**”) which specialized in the design, distribution, installation, wear monitoring of wear liners, rubber lining, screens for mining handling industries. We increased our market share in Australia by acquiring our competitor at the time, which gave us access to a ready platform to launch our conveyor accessories and screens in that market.

Our total income was ₹1,793.86 million, ₹8,566.84 million, ₹6,955.42 million and ₹6,430.13 million for the three months period ended June 30, 2021 and Fiscals 2021, 2020 and 2019, respectively. Our restated total profit for the period/year was ₹118.82 million, ₹1,364.05 million, ₹655.04 million and ₹326.70 million for the three months period ended June 30, 2021 and Fiscals 2021, 2020 and 2019 respectively. Our net cash generated from operating activities was ₹492.35 million, ₹1,702.46 million, ₹1,283.75 million and ₹686.69 million for the three months period ended June 30, 2021 and in Fiscals 2021, 2020 and 2019 respectively. Our EBITDA was ₹296.79 million, ₹2,386.42 million, ₹1,172.28 million and ₹1,060.03 million for the three months period ended June 30, 2021 and the Fiscals 2021, 2020 and 2019, having increased at a CAGR of 50.04%, from Fiscal 2019 to Fiscal 2021. Our EBITDA Margin (EBITDA as a percentage of our total income) was 16.54%, 27.86%, 16.85% and 16.49%, respectively, in the same periods, having increased at a CAGR of 29.99%, from Fiscal 2019 to Fiscal 2021.

For Fiscals 2021, 2020 and 2019, our Return on Capital Employed (“**ROCE**”) was 24.76%, 11.17% and 11.12%. Our net worth was ₹6,311.52 million ₹6,137.22 million, ₹4,624.89 million and ₹4,011.05 million as on June 30,

2021, March 31, 2021, March 31, 2020 and March 31, 2019, respectively, while our Return on Equity (“ROE”) was 22.23%, 14.16% and 8.14% for the Fiscals 2021, 2020 and 2019.

## Significant Factors Affecting our Results of Operations

### *Macro-Economic Conditions and Factors Affecting the Sectors in which we Operate*

We derive our revenue from the mining, mineral processing and material handling industries across the world. Sales of our products, which are consumables, is directly linked to the processing and handling of ores by the respective industries. This is further dependent on the demand cycle of the underlying metals, and the number of operational processing and handling plants in a given period. The mining sector is highly vulnerable to geo-political changes, local mining regulations and global demand / supply imbalances, which have resulted in changes in metal prices across cycles. Despite volatility in metal prices, we are insulated from this cyclicity because our products are consumed as long as a mill or mineral processing facility is operational. Some of the general macro-economic factors that can affect demand for our products and as a result for our business, include the following:

- Geo-political risks and local political risks associated with the countries we have manufacturing or sales operations, particularly related to mining and mineral processing industries.
- Compliance with a variety of local laws and regulations, which may be materially different than those to which we are subject in India, including legal constraints on ownership and corporate structure, environmental, health, safety, labour and accounting laws.
- Economic and financial conditions, including potential hyperinflationary conditions, any instability of credit markets, foreign currency fluctuations and controls, particularly the ability to repatriate funds to India and to any other countries.
- Global and local economic growth, fiscal stability, growth in personal disposable incomes impact consumption and hence demand for end products.
- Gross capital formation, planned expenditure and government revenues and its impact on overall levels of capital expenditure.
- Global oil prices, which impacts industries globally and in India.
- Trade agreements with nations and international trading barriers by India and other countries, export and import regulations and tariffs.
- Global and local shortages of input materials, which in our case, primarily includes carbon black, high grade natural rubber, polyurethane rubber, styrene-butadiene rubber and wear plates. Refer to “**Risk Factors – We are dependent on a few key suppliers of certain raw materials and do not have long term contracts or exclusive arrangements with these key suppliers. Accordingly, the loss of, or a significant reduction in supply by, such suppliers could adversely affect our business, financial condition and results of operations.**” on page 28 for details on the impact of raw material supply on our operations.
- Logistical challenges and bottlenecks in movement of cargo across international regions. Refer to “**Risk Factors – We are dependent on third party logistic and support service providers for the delivery of raw materials and finished products and any disruptions in their services including transportation services or a decrease in the quality of their services may adversely affect our business, financial condition and results of operations.**” on page 25 for details on third party logistics and support services on our operations.
- Volatility in exchange rates, which has an impact on our Company’s ability to win against local competitors.

The current outbreak of COVID-19 (“Covid”) pandemic has adversely impacted the global economy. The World Health Organization declared the outbreak of COVID-19 as a public health emergency of international concern on January 30, 2020 and a pandemic on March 11, 2020. The Government of India announced a nation-wide lockdown on March 23, 2020 and imposed several restrictions. Covid continues to spread across the globe and has since affected the world economy including India, leading to significant volatility and a decline in financial markets and general economic activity. However, Covid had limited impact on the mining industry, since it was

declared as an essential service in various countries globally. Mines were running continuously since temporary shutdowns of mines are expensive and therefore there was resilient demand for critical mining consumables for regular operations.

Since our products are critical to operate consumables for the mines, we were largely unaffected. Further, our plant in Chile remained functional with no halts in operations, our plant in South Africa had limited halt in operations, however our plant in Australia was impacted due to stricter and longer inter-boundaries lockdown within Australia, which has since been relaxed. Our strong customer profile, which includes senior miners and mining industries, were resilient during the period. However, we faced temporary logistical issues in terms of limited availability of labour, logistics and supply chain constraints. Our exports and production in some of our domestic facilities were temporarily disrupted from March 2020 onwards, across successive waves of national and regional lockdowns in India. Since then, we have resumed our operations in phases as per the Government of India and state government's directives. Our plant utilization has improved, raw material suppliers have resumed operations and supply and logistics have become more regular. The future impact of COVID-19 or any other severe communicable disease on our business and results of operations depends on several factors including those discussed in "**Risk Factors – The extent to which COVID-19 affects our business, results of operations and financial condition will depend on future developments, which are uncertain and cannot be predicted.**" on page 36. We are continuously monitoring the economic conditions and have outlined certain measures to combat the pandemic situation and to minimize the impact on our business.

### ***Raw Material Costs, Operating Costs and Efficiencies***

Our business, financial condition, results of operations and prospects are significantly impacted by the prices of raw materials purchased by us as well as any changes in global price indices, particularly, Steel and natural and synthetic rubber. As we are exporting majority of the goods across the globe and most of our inputs are imported we are also effected severely on account of global sea freight indices.

Raw material costs (consisting of the costs of materials consumed and changes in inventories of finished goods and work-in-progress) constitute the most significant portion of our expenditures, representing 39.58%, 40.20 %, 39.98%, and 40.61% of our revenue from operations for the three months period ended June 30, 2021 and Fiscals 2021, 2020 and 2019, respectively. Our financial condition and results of operations are significantly impacted by the availability and costs of raw materials, particularly wear steel, rubber and carbon black.

We rely significantly on selective suppliers for procurement of inputs required for manufacturing our products. Our stringent vendor approval process keeps a tab on how many suppliers are involved in any particular commodity. Raw material pricing can be volatile due to a number of factors beyond our control, including global demand and supply, general economic and political conditions, transportation and labour costs, labour unrest, natural disasters, competition, import duties, fuel prices and availability, power tariffs and currency exchange rates, and there are uncertainties inherent in estimating such variables, regardless of the methodologies and assumptions that we may use. This volatility in commodity prices can significantly affect our raw material costs. Further, volatility in fuel prices can also affect commodity prices worldwide which may significantly increase our raw material costs. We are currently having a hybrid pricing strategy.

We work on forecasted prices looking at the leading indicators. These forecasts are shared with the sales and offer preparation team so as they can quote basis the information at hand. But most of the forecasts are only accurate to a certain degree and hence we carry the risk while offer preparation which may impact our contributions either way.

Given the nature of our business, our ability to manage our operating costs and efficiencies is critical to maintaining our competitiveness and profitability. Our profitability is partially dependent on our ability to spread fixed production costs over higher production volumes. In addition, we face pressure from our key customers to reduce prices, and in order to maintain our profitability, we must be able to boost our productivity and reduce our operating expenses. We continually undertake efforts to reduce our costs in order to protect our margins, such as enhancing utilization of the press capacity, segregation and planning of orders to reduce the idle time by prioritizing the inputs for manufacturing, rationalising suppliers, negotiating volume discounts, outsourcing non-critical processes, reducing energy usage and rationalising our manpower. Our ability to reduce our operating costs in line with customer demand is subject to risks and uncertainties, as our costs depend, in part, on external factors beyond our control.

The improvements in operational efficiency is generally a gradual process. All our production facilities are equipped with a set up to take care of most of our customer's requirement irrespective of the location with



minimum impact. This gives additional option to the operation and planning team to alter the plan and utilize the plants to its maximum capacity. With increasing press utilization, our revenue is directly linked.

Our EBITDA Margin (EBITDA as a percentage of our total income) was 16.54%, 27.86%, 16.85% and 16.49%, respectively, for the three months period ended June 30, 2021 and Fiscals, 2021, 2020 and 2019, having increased at a CAGR of 29.99%, from Fiscal 2019 to Fiscal 2021.

Employee benefits expense comprises a large part of our expense after raw material costs. For the three months period ended June 30, 2021 and Fiscals 2021, 2020 and 2019, our employee benefits expense aggregated to ₹350.25 million, ₹1,226.70 million, ₹1,153.34 million and ₹1,113.91 million respectively, and, as a percentage of our revenue from operations, were 20.22%, 15.23%, 16.84%, and 17.58%, respectively in those periods. Our employee benefit expenses are affected by statutorily prescribed minimum wage and increase in headcount due to increase in volumes. As a material portion of our overall manpower is located in India, rising wages in India will have a material impact on our net income. In recent times, labour related costs have been rising in India. While our employee benefit expenses may increase in absolute terms, we have been able to improve our operational efficiencies, which has resulted in a reduction in our employee benefits expense as a percentage of our revenue from operations.

We also incur certain costs in order to ensure that the products that we supply to our customers are of high quality and free of defects. Such costs relate to matters such as capital expenditure, manpower, systems deployment and rejection and re-working of products. Quality control is critical to our operations and a failure to prevent the passing down of defects to our customers may lead to significant costs.

#### ***Ability to maintain and grow demand for our products from key customers***

We have a diversified client base with our top 10 customers accounting for 34.19%, 32.62%, 31.31% and 22.51% of our sale of products and services for the three months period ended June 30, 2021 and Fiscals 2021, 2020 and 2019, respectively. Changes in inventory and production levels of our key customers could lead to changes in demand for our products over time, which can have a significant impact on our revenue growth. We consciously follow a policy of diversifying our customer base. The loss of key customers has the potential to adversely impact our financial position.

As our products are largely consumed in the after-market, it provides for stable recurring revenues at each client site. However, the level of growth in demand for our product depends on our ability to convert existing and new customers through bringing new opportunities of customer value creation, focus on product quality relative to other competitors in the market. Our ability to drive value to our customers relative to competition is also key in helping us improve pricing and realisations over time.

We do not have a single competitor covering the entire product range and competing with us globally for market share. However, we face competition from both international and local players in respective geographies, product segments or sub-segments in which we operate. Our key competitive strengths include quality, cost, delivery, technical capability, and quality of management. Our sales to our customers also depend largely on the number and type of products that we supply to them and our ability to increase our overall share of our customers' purchases.

While our customers continue to implement various cost-cutting strategies, which include restructuring of operations, relocation of production/ procurement to low-cost regions, vendor rationalisation, etc., we believe that the criticality of the products we manufacture, our strong customer relationships, lack of alternate vendors, high switching costs, our ability to quickly scale up our production, our ability to maintain high quality and delivery commitments and ability to produce a diverse range of products across a number of geographies will allow us meet these business challenges.

Accordingly, our operations have generally grown with our customers' businesses over time, while being more resilient than our customers to any changes associated with pricing and capital expenditure cycles. While our high-touch sales model with continuous customer interaction enables us to forecast our demand basis their business plans, it is difficult for us to predict with certainty when our customers will decide to increase or decrease inventory levels or levels of production, or initiate abrupt changes in strategic direction, or whether future inventory levels will be consistent with historical levels. Any increases or decreases in the levels of inventory and activity by our customers, in turn, are likely to have a positive or negative effect on our revenues and operational results.

### ***Expansion in Product Portfolio and addressable market***

Our product portfolio is diverse and includes a range of consumables required in the mines and mineral processing industry. In the sequence of their usage in the mineral processing mines, after blasting to floatation, our products include chutes and its liners, grinding mill liners, trommels and screens, hydrocyclones, pumps and flotation parts and conveyor products.

Our product range is engineered with a combination of mineral processing engineering, mechanical engineering and material sciences, while utilising our expertise in tribology. Our historical growth among existing and new customers is driven by our ability to leverage our strong engineering skills and expertise, combined with our ability to design and provide custom solutions and cater to global demand through our global network of manufacturing facilities. We intend to continue to use these capabilities to increase our wallet share among existing customers, and add new customers. We have also added in-house manufacturing capabilities over time that position us better as a comprehensive solutions provider across business segments. This will in turn, enable us to drive new growth opportunities among existing customers.

We have a track record of developing and commercializing a diverse and innovative product portfolio of 55 mineral processing and material handling products over the years, including DynaPrime launched by us in 2018. DynaPrime has unlocked a new addressable market for us. As of March 31, 2021, our order book for DynaPrime includes 23 target sites. As of June 30, 2021, our order book for DynaPrime includes 28 target sites. Our launch of DynaPrime has enabled us to increase our addressable market from catering to rubber and composite liners to large mineral processing units which conventionally had relied on traditionally used metallic liners. According to the F&S Report, we are the only player providing a 'hybrid liner' across both larger SAG mills in the segment range of (>9.5 dia) and Ball Mills (>5.5 dia). Going forward, we believe that important pillars of growth in our results of operations will be continuous momentum and success of DynaPrime pilots and a sustained DynaPrime order book, coupled with momentum in other differentiated product launches backed by our strong in-house R&D capabilities.

### ***Foreign exchange fluctuations***

We are exposed to foreign exchange rate fluctuations (mainly in USD, CAD, AUD, EUR, SGD, ZAR CLP, GHS and GBP) in respect of (i) revenue from overseas business in foreign denominations; (ii) our foreign currency denominated borrowings; (iii) currency translation losses for the purpose of preparing our consolidated financial statements (which are presented in Indian Rupees), on account of our global operations; and (iv) value of our foreign assets. While we seek to pass on all losses on account of foreign currency fluctuations to our customers, our ability to foresee future foreign currency fluctuations is limited. For details on the impact of foreign exchange on the results of our operations, see "***Risk Factors – Depreciation of the Indian Rupee and exchange rate fluctuations in currencies in which we do business or have outstanding borrowings may materially and adversely impact our business, financial condition and results of operations.***" on page 28.

### ***Operational efficiencies and margin expansion***

We intend to continue enhancing our operational efficiencies, to increase economies of scale, better absorb our fixed costs, reduce our other operating costs and strengthen our competitive position. We have, in the past and intend to in the future, continue using a variety of other manufacturing strategies and cost reduction strategies to continue to improve our operational efficiencies. For example, to attain cost structure sustainability over the years, we emphasize on economies of scale, employment of learnings acquired in manufacturing composite components, and a robust supply chain developed for sourcing of raw materials. To meet the growing demand from our customers, we have invested in our manufacturing facilities, infrastructure, machines, equipment and technology to allow us to offer a diverse product suite, reduce operating costs and drive productivity and scale of our business without incurring significant incremental costs in the future. In addition, we shall also focus on cycle time reduction by adopting advanced technologies that will also result in process optimisation, thereby increasing our capacity to undertake more number of projects.

### ***Funds for Capital Expenditure and Working Capital Requirements***

Given the sector in which we operate, we have substantial capital expenditure and working capital requirements for growth. We have significantly invested in our manufacturing capacities to meet the growing demand from our customers and to expand our product portfolio. For the three months period ended June 30, 2021 and the last three Fiscals 2021, 2020 and 2019, additions to our property, plant and equipment were ₹64.86 million, ₹243.29 million, ₹237.91 million and ₹244.30 million, respectively.

As of the three months period ended June 30, 2021 and Fiscals 2021, 2020 and 2019, the net carrying value of property, plant and equipment (PPE) was ₹1,693.12 million, ₹1,691.96 million, ₹1,691.49 million, and ₹1,852.56 million. Going forward, we may spend on capex to take care of growing demand from our customers from internal sources and external borrowing.

For Fiscals 2021, 2020 and 2019, our ROCE was 24.76%, 11.17% and 11.12%. Our net worth was ₹6,311.52 million, ₹6,137.22 million, ₹4,624.89 million and ₹4,011.05 million as on June 30, 2021, March 31, 2021, March 31, 2020 and March 31, 2019, respectively, while our ROE was 22.23%, 14.16% and 8.14% for the Fiscals 2021, 2020 and 2019, respectively.

Our finance costs in earlier years, have been higher due to higher exposure to debt, taken for the purpose of acquisitions and capex at the time, with a view to further enhance our manufacturing capacities not only in India but other parts of the world. Our finance costs include interest expenses, other borrowing costs, Interest on finance charges on lease liabilities and net gain/loss on foreign currency transactions and translation. In the three months period ended June 30, 2021 and the last three Fiscals, our finance cost is gradually going down due to repayment of borrowings and lower interest rates due to subvention in export borrowing. The finance costs was ₹36.13 million, ₹172.78 million, ₹214.39 million and ₹236.02 million for the three months period ended June 30, 2021 and Fiscals 2021, 2020 and 2019 respectively. As a percentage of our total income, our finance costs is 2.01%, 2.02%, 3.08% and 3.67% for the three months period ended June 30, 2021 and Fiscal 2021, 2020 and 2019, respectively, which is showing a gradual downtrend. There is no guarantee that the rate of interest will continue to be soft in the future and that the government will continue to subsidise the interest rate by way of subventions to the exporters in the future. Any changes to these stands will result in higher finance cost in the future for the Company.

As of June 30, 2021, our aggregate outstanding borrowings was ₹1,842.38 million. As of June 30, 2021, our aggregate cash and cash equivalent (including investments under current assets) was ₹2,524.75 million, which makes our net debt position favourable.

Further given the sector in which we operate, we need to buy the majority of our inputs either in advance or with lesser credit period and in turn we have to provide the higher credit period to our customers due to market conditions and larger logistics duration for some geographies for exports and competition from both local and global players. Further, there are inputs for which we rely on a few suppliers in India and worldwide and hence require to have little larger inventory to avoid disruption in production for want of materials. All these factors resulted in higher involvement of working capital requirement in the business. Our gross working capital (total current assets less current investments) in the three months period ended June 30, 2021 and Fiscals 2021, 2020 and 2019 was ₹4,843.36 million, ₹4,665.23 million, ₹4,025.93 million and ₹3,996.65 million, respectively.

### **Critical Accounting Policies**

#### **Critical estimates and judgements**

The preparation of Restated Consolidated Financial Information requires the use of accounting estimates which, by definition, will seldom equal the actual results. Company also needs to exercise judgement in applying the accounting policies.

This note provides an overview of the areas that involved a higher degree of judgement or complexity, and of items which are more likely to be materially adjusted due to estimates and assumptions turning out to be different than those originally assessed.

- (a) Estimation of defined benefit obligation

#### Post-employment benefits

- (i) Defined contribution plan - We make provident fund, superannuation fund and other fund contributions to defined contribution plans for qualifying employees. Under the schemes, we are required to contribute a specified percentage of the payroll costs to fund the benefits. The contributions payable to these plans by us are at rates specified in the rules of the schemes.
- (ii) Defined benefit plan (Gratuity) - We provide for gratuity, a defined benefit retirement plan covering eligible employees. As per the scheme, the gratuity trust fund managed by the trust, makes payment to vested employees on retirement, death, incapacitation or termination of employment, of an amount based on the respective employee's eligible salary (half month's salary) depending upon the tenure of service

subject to a revised maximum limit of amount payable under Payment of Gratuity Act. Liabilities with regard to the gratuity plan are determined by actuarial valuation based upon which, we contribution to the gratuity fund.

- (iii) Other long term employee benefit plan - Leave obligations covers our liability for other long term benefits. Compensated absences covers our liability for earned leave. As we do not have an unconditional right to defer the payment beyond 12 months, the entire amount has been treated as current.

(b) Impairment of Goodwill

Goodwill is tested for impairment at least on annual basis or more frequently when events or change in circumstances indicate that it might be impaired. The recoverable amount of the Cash Generating unit (CGU) is determined based on value in use calculations which require the use of assumptions. The calculations use cash flow projection based on financial budgets approved by management covering a five year period. We use various assumptions inter-alia growth in the revenue, earnings before Interest, tax depreciation and amortisation. (EBITDA), long term growth rates, discount rates to reflect the risk involved.

(c) Current and Deferred Tax

We review the carrying amount of deferred tax assets at the end of each reporting period.

The current income tax charge is calculated on the basis of the tax laws enacted or substantively enacted at the end of the reporting period in the countries where we operate and generate taxable income. We periodically evaluate positions taken in tax returns with respect to situations in which applicable tax regulation is subject to interpretation. We establish provisions where appropriate, on the basis of amounts expected to be paid to the tax authorities.

Deferred income tax is provided in full, using the liability method, on temporary differences arising between the tax bases of assets and liabilities and their carrying amounts in the Restated Consolidated Financial Information. However, deferred tax liabilities are not recognised if they arise from the initial recognition of goodwill. Deferred income tax is also not accounted for if it arises from initial recognition of an asset or liability in a transaction other than a business combination that at the time of the transaction affects neither accounting profit nor taxable profit (tax loss). Deferred income tax is determined using tax rates (and laws) that have been enacted or substantially enacted by the end of the reporting period and are expected to apply when the related deferred income tax asset is realised or the deferred income tax liability is settled.

Deferred tax assets are recognised for all deductible temporary differences and unused tax losses only if it is probable that future taxable amounts will be available to utilise those temporary differences and losses. Deferred tax liabilities are not recognised for temporary differences between the carrying amount and tax bases of investments in subsidiaries, branches and interest in joint arrangements where the Group is able to control the timing of the reversal of the temporary differences and it is probable that the differences will not reverse in the foreseeable future. Deferred tax assets are not recognised for temporary differences between the carrying amount and tax bases of investments in subsidiaries, branches and associates and interest in joint arrangements where it is not probable that the differences will reverse in the foreseeable future and taxable profit will not be available against which the temporary difference can be utilised.

Deferred tax assets and liabilities are offset when there is a legally enforceable right to offset current tax assets and liabilities and when the deferred tax balances relate to the same taxation authority. Current tax assets and tax liabilities are offset where the entity has a legally enforceable right to offset and intends either to settle on a net basis, or to realise the asset and settle the liability simultaneously.

Current and deferred tax is recognised in restated consolidated statement of profit or loss, except to the extent that it relates to items recognised in restated consolidated statement of other comprehensive income or directly in equity. In this case, the tax is also recognised in restated consolidated statement of other comprehensive income or directly in equity, respectively.

Minimum Alternate Tax (MAT) credit is recognised as an asset only when and to the extent there is convincing evidence that the group will pay normal income tax during the specified period. Such asset is reviewed at each balance sheet date and the carrying amount of the MAT credit asset is written down to the extent there is no longer a convincing evidence to the effect we will pay normal income tax during the specified period.

(d) Critical judgement in determining the lease term

We determine the lease term on the basis of termination and renewal options in various lease contracts where we apply our judgement.

#### As a lessee

Our significant leasing arrangements include assets dedicated for use under long-term arrangements, lease of land, office space, equipment, vehicles and some IT equipment. Lease of land have lease term of up to 60 years, leases of plant and equipment and office equipments have lease terms between 2 to 30 years, offices and guest houses generally have lease terms between 12 months to 60 years and vehicle generally have lease term between 2 years to 5 years. Lease terms are negotiated on an individual basis and contain a wide range of different terms and conditions. Until March 31, 2019, leases were classified as either finance leases or operating leases. From April 1, 2019, leases are recognised as a right-of-use asset and a corresponding liability at the date at which the leased asset is available for use. We also have certain leases of offices and guest houses with lease term of up to 12 months. We apply the 'short-term lease' recognition exemptions for these leases. For leases recognised under long term arrangements involving use of a dedicated asset, non-lease components are excluded based on the underlying contractual terms and conditions.

For the purpose of preparing Restated Consolidated Financial Information, Ind AS 116 has been applied retrospectively with effect from April 1, 2018.

#### Transition related disclosures

- (i) The weighted average incremental borrowing rate applied to lease liabilities as at April 1, 2018 ranges from 2.59% to 11.70%.
- (ii) The following is the summary of practical expedients elected on initial application:
  - accounting for operating leases with a remaining lease term of less than 12 months as at April 1, 2018 as short-term leases;
  - excluding initial direct costs for the measurement of the right-of-use asset at the date of initial application; and
  - using hindsight in determining the lease term where the contract contains options to extend or terminate the lease.

#### **Compliance with Ind AS**

Our Restated Consolidated Financial Information have been prepared to comply in all material aspects with Indian Accounting Standards (Ind AS) notified under Section 133 of the Companies Act, 2013, Companies (Indian Accounting Standards) Rules, 2015 and Companies (Indian Accounting Standards) Amendment Rules, 2016 and other relevant provisions of the Act.

#### **Historical cost convention**

Our Restated Consolidated Financial Information have been prepared as going concern on accrual basis and under the historical cost convention, except for:

- certain financial assets and liabilities measured at fair value (refer accounting policy regarding financial instruments);
- defined benefit plans – plan assets measured at fair value; and
- share-based payments.

#### **Current versus non-current classification**

All assets and liabilities have been classified as current or non-current as per our operating cycle and other criteria set out in the Indian Accounting Standards (Ind AS) and Schedule III to the Companies Act, 2013. Based on the nature of products and the time between the acquisition of assets for processing and their realisation in cash and cash equivalents, we have ascertained our operating cycle as 12 months for the purpose of current – non-current classification of assets and liabilities.

## **Use of estimates**

The preparation of Restated Consolidated Financial Information requires the use of accounting estimates which, by definition, will seldom equal the actual results. Estimates are continually evaluated. They are based on historical experience and other factors, including expectations of future events that may have a financial impact on us and that are believed to be reasonable under the circumstances.

## **Principles of consolidation and equity accounting**

### **Subsidiaries**

Subsidiaries are all entities over which we have control. We control an entity when we are exposed to, or have a right to, variable returns from our involvement with the entity and have the ability to affect those returns through our power to direct the relevant activities of the entity. Subsidiaries are fully consolidated from the date on which control is transferred to us. They are deconsolidated from the date that control ceases. The acquisition method of accounting is used to account for business combinations by us. We combine the financial statements of the Company and its subsidiaries line by line adding together like items of assets, liabilities, equity, income and expenses. Intercompany transactions, balances and unrealised gains on transactions between the Company and subsidiaries are eliminated. Unrealised losses are also eliminated unless the transaction provides evidence of an impairment of the transferred asset. Accounting policies of subsidiaries have been changed where necessary to ensure consistency with the policies adopted by us. IND AS 12 'Income Tax' applies to temporary differences that arise from the elimination of profits and losses resulting from intercompany transaction.

Non-controlling interests in the results and equity of subsidiaries are shown separately in the restated consolidated statement of profit and loss, restated consolidated statement of changes in equity and restated consolidated statement of assets and liabilities respectively.

### **Interest in joint ventures accounted for using equity method**

Under Ind AS 111, joint arrangements, investments in joint arrangements are classified as either joint operations or joint ventures. The classification depends on the contractual rights and obligations of each investor, rather than the legal structure of the joint arrangement. We only have investment in joint venture.

Under the equity method of accounting, the investment is initially recognised at cost and adjusted thereafter to recognise our share of the post-acquisition profits or losses of the investee restated in profit and loss, and our share of other comprehensive income of the investee in restated other comprehensive income. Dividend received or receivable from joint venture is recognised as a reduction in the carrying amount of investment.

When our share of losses in an equity-accounted investment equals or exceeds its interest in the entity, including any other long term receivables, we do not recognise further losses, unless it has incurred obligations or made payments on behalf of the other entity.

Unrealised gains on transactions between us and our joint venture are eliminated to the extent of our interest in joint venture. Unrealised losses are also eliminated unless the transaction provides evidence of an impairment of the asset transferred. Accounting policies of equity accounted investee are changed where necessary to ensure consistency with the policies adopted by us.

### **Property, plant and equipment**

Freehold land is carried at historical cost. All other items of property plant and equipment are stated at historical cost net of accumulated depreciation and accumulated impairment losses, if any. Historical cost includes expenditure that is directly attributable to the acquisition of the items.

Subsequent costs are included in the asset's carrying amount or recognised as a separate asset, as appropriate, only when it is probable that future economic benefits associated with the item will flow to us and the cost of the item can be measured reliably. The carrying amount of any component accounted for as a separate asset is derecognised when replaced. All other repairs and maintenance are charged to restated consolidated statement of profit and loss during the reporting period in which they are incurred.

An asset's carrying amount is written down immediately to its recoverable amount if the asset's carrying amount is greater than its estimated recoverable amount. Gains and losses on disposals are determined by comparing proceeds with carrying amount. These are included in the restated consolidated statement of profit and loss.

On transition to Ind AS, the Group has elected to continue with the carrying value of its property plant and equipment measured at the previous GAAP and use that carrying value as the deemed cost of property plant and equipment.

## Depreciation

Depreciation is calculated using a straight line method to allocate the cost of the assets, net of their residual values, over their estimated useful lives, wherever applicable. The estimated useful lives of the property, plant and equipment have been presented below:

Class of assets	Estimated useful life (in years)
Buildings	30 - 60 years
Plant and Equipment*	3 - 8 years
Furniture and Fixtures	10 years
Vehicles	5-8 years
Office equipment	5 years
Electrical installation	10 years

*\*For these class of assets, based on internal assessment and independent technical evaluation carried out by external valuers, we believe that the useful lives as given above best represent the year over which we expect to use these assets. Hence, the useful lives for these assets are different from the useful lives as prescribed under Part C of Schedule II to the Companies Act, 2013.*

Leasehold improvements are depreciated over the shorter of their useful life or the lease term, unless the entity expects to use the assets beyond the lease term. The assets' residual values and useful lives are reviewed by the management, and adjusted if appropriate, at the end of each reporting period.

## Intangible assets

Goodwill on acquisition of subsidiaries is included in intangible assets. Goodwill is not amortised but it is tested for impairment annually, or more frequently if events or changes in circumstances indicate that it might be impaired, and is carried at cost less accumulated impairment losses if any. Gains and losses on the disposal of an entity include the carrying amount of goodwill relating to the entity sold.

Goodwill is allocated to cash-generating units for the purpose of impairment testing. The allocation is made to those cash-generating units or groups of cash-generating units that are expected to benefit from the business combination in which the goodwill arose. The units or groups of units are identified at the lowest level at which goodwill is monitored for internal management purposes.

Computer software is stated at cost of acquisition net of accumulated amortisation and accumulated impairment losses, if any. Costs associated with maintaining software programmes are recognised as an expense as incurred.

An asset's carrying amount is written down immediately to its recoverable amount if the asset's carrying amount is greater than its estimated recoverable amount. Gains and losses on disposals are determined by comparing proceeds with carrying amount. These are included in our restated consolidated statement of profit and loss.

On transition to Ind AS, the Group has elected to continue with the carrying value of its intangible assets measured at the previous GAAP and use that carrying value as the deemed cost of intangible assets.

## Amortisation

We amortise computer software using the straight line method over the following periods:

Class of assets	Estimated useful life (in years)
Software	3 Years

## Research and development expenditure

Research expenditure and development expenditure that do not meet the criteria mentioned below are recognised as an expense as incurred. Development costs previously recognised as an expense are not recognised as an asset in a subsequent period. Property, plant and equipment used in Research and Development are capitalised.

Development costs are recognised as intangible assets when the following criteria are met:

- (a) it is technically feasible to complete the intangible asset so that it will be available for use;

- (b) management intends to complete the intangible asset and use or sell it;
- (c) there is an ability to use or sell the intangible asset;
- (d) it can be demonstrated how the intangible asset will generate probable future economic benefits;
- (e) adequate technical, financial and other resources to complete the development and to use or sell the intangible asset are available; and
- (f) the expenditure attributable to the intangible asset during its development can be reliably measured.

Capitalised development costs are recorded as intangible assets and amortised from the point at which the asset is available for use.

### **Impairment**

At each balance sheet date, we review the carrying values of our property, plant and equipment and intangible assets to determine whether there is any indication that the carrying value of those assets may not be recoverable through continuing use. If any such indication exists, the recoverable amount of the asset is reviewed in order to determine the extent of impairment loss (if any). Where the asset does not generate cash flows that are independent from other assets, we estimate the recoverable amount of the cash generating unit to which the asset belongs.

Recoverable amount is the higher of fair value less costs to sell and value in use. In assessing value in use, the estimated future cash flows are discounted to their present value using a pre-tax discount rate that reflects current market assessments of the time value of money and the risks specific to the asset for which the estimates of future cash flows have not been adjusted. An impairment loss is recognised in our restated consolidated statement of profit and loss as and when the carrying value of an asset exceeds its recoverable amount.

Where an impairment loss subsequently reverses, the carrying value of the asset (or cash generating unit) is increased to the revised estimate of its recoverable amount so that the increased carrying value does not exceed the carrying value that would have been determined had no impairment loss been recognised for the asset (or cash generating unit) in prior years. A reversal of an impairment loss is recognised in our restated consolidated statement of profit and loss immediately.

### **Investment Properties**

Property that is held for long term rental yields or for capital appreciation or both, and is not occupied by us, is classified as Investment property. Investment property is measured initially at its cost, including related transaction costs and where applicable borrowing costs. Subsequent expenditure is capitalised to the assets carrying amount only when it is probable that future economic benefits associated with the expenditure will flow to us and the cost of the item can be measured reliably. All repair and maintenance cost are expensed when incurred. When part of Investment property is replaced, the carrying amount of the replaced part is derecognised.

On transition to Ind AS, we have elected to continue with the carrying value of its investment properties measured at the previous GAAP and use that carrying value as the deemed cost of investment properties.

### **Business combinations**

Acquisition of subsidiaries and businesses are accounted for using the acquisition method under Ind AS 103. The consideration transferred for acquisition of a business generally comprises of fair value of assets transferred, liabilities incurred by us to the former owners of the acquired businesses, and equity interests issued by us. Acquisition related costs are expenses as incurred in the restated consolidated statement of profit and loss.

Goodwill arising on acquisition is recognised as an asset and measured at cost, being the excess of the consideration transferred in the business combination over the fair value of the net identifiable assets acquired. Where the fair value of the net identifiable assets exceed the consideration transferred, the difference is recognised in other comprehensive income and accumulated in equity as capital reserve provided there is clear evidence of the underlying reasons for classifying the business combination as a bargain purchase. In other cases, the bargain purchase gain is recognised directly in equity as capital reserve.

We treat transactions with non-controlling interests that do not result in a loss of control as transactions with equity owners of our group. A change in ownership interest results in an adjustment between the carrying amounts



of the controlling and non-controlling interests to reflect their relative interests in the subsidiary. Any difference between the amount of the adjustment to non-controlling interests and any consideration paid or received is recognised within equity.

Business combinations arising from transfers of interests in entities that are under the common control are accounted for using the pooling of interest method. The difference between any consideration transferred and the aggregate historical carrying values of assets and liabilities of the acquired entity are recognised in shareholder's equity.

When a transaction or other event does not meet the definition of a business combination due to the asset or group of assets not meeting the definition of a business, it is termed an 'asset acquisition'. In such circumstances, the acquirer:

- (a) identifies and recognises the individual identifiable assets acquired; and
- (b) allocates the cost of assets and liabilities to the individual identifiable assets and liabilities on the basis of their relative fair values at the date of purchase.

Such a transaction or event does not give rise to goodwill or bargain purchase gain.

## **Financial instruments**

### Investment in debt instruments

The financial assets are classified in the following categories:

- (a) financial assets measured at amortised cost;
- (b) financial assets measured at fair value through profit and loss (FVTPL); and
- (c) financial assets measured at fair value through other comprehensive income (FVOCI).

The classification of financial assets depends on our business model for managing financial assets and the contractual terms of the cash flow.

At initial recognition, the financial assets are measured at its fair value plus, in the case of a financial asset not at fair value through profit or loss, transaction costs that are directly attributable to the acquisition of the financial asset. Transaction costs of financial assets carried at fair value through profit and loss are expensed in restated consolidated statement of profit and loss.

### Financial assets measured at amortised cost

Assets that are held for collection of contractual cash flows where those cash flows represent solely payments of principal and interest are measured at amortised cost. After initial recognition, such financial assets are subsequently measured at amortised cost using the effective interest rate method. The losses arising from impairment are recognised in the restated consolidated statement of profit and loss.

### Financial assets measured at fair value through other comprehensive income (FVOCI)

Financial assets are measured at fair value through other comprehensive income if these financial assets are held within a business model whose objective is achieved by both collecting contractual cash flows and selling financial assets and the contractual terms of the financial asset give rise on specified dates to cash flows that are solely payments of principal and interest on the principal amount outstanding.

### Financial assets measured at fair value through profit and loss (FVTPL)

Assets that do not meet the criteria for amortised cost or FVOCI are measured at fair value through profit or loss. A gain or loss on a debt investment that is subsequently measured at fair value through profit or loss is recognised in restated consolidated statement of profit and loss in the period in which it arises. Investments in units of mutual funds are subsequently measured at FVTPL and the changes in fair value are recognised in restated consolidated statement of profit and loss.

### De-recognition of financial asset

A financial asset is derecognised only when:

- (a) we have transferred the rights to receive cash flows from the financial asset; or
- (b) it retains the contractual rights to receive the cash flows of the financial asset, but assumes a contractual obligation to pay the cash flows to one or more recipients.

#### Impairment of financial assets

We assess on a forward looking basis the expected credit losses associated with its financial assets carried at amortised cost and FVOCI debt instruments. The impairment methodology applied depends on whether there has been a significant increase in credit risk. For trade receivables only, we apply the simplified approach required by Ind AS 109, which requires expected lifetime losses to be recognised from initial recognition of the receivables.

#### **Financial liabilities**

Borrowings are initially recognised at fair value, net of transaction costs incurred. Financial liabilities are subsequently measured at amortised cost using the effective interest rate method. Any difference between the proceeds (net of transaction costs) and the redemption amount is recognised in restated consolidated statement of profit and loss over the period of the borrowings using the effective interest method.

Borrowings are classified as current liabilities unless we have an unconditional right to defer settlement of the liability for at least 12 months after the reporting period. Where there is a breach of a material provision of a long-term loan arrangement on or before the end of the reporting period with the effect that the liability becomes payable on demand on the reporting date, the entity does not classify the liability as current, if the lender agreed, after the reporting period and before the approval of the Restated Consolidated Financial Information, not to demand payment as a consequence of the breach.

Trade and other payables represent liabilities for goods and services provided to the group prior to the end of the financial year which are unpaid. The amounts are unsecured and are usually paid within 30-90 days of recognition. Trade and other payables are presented as current liabilities unless payment is not due within 12 months after the reporting period. They are recognised initially at their fair value and subsequently measured at amortised cost using the effective interest method.

#### **De-recognition of financial liabilities**

A financial liability (or a part of financial liability) is de-recognised from our restated consolidated statement of assets and liabilities when the obligation specified in the contract is discharged or cancelled or expired.

#### **Derivative instruments**

Derivatives are only used for economic hedging purposes and not as speculative investments. We use certain derivative financial instruments to reduce business risks which arise from its exposure to foreign exchange and interest rate fluctuations. The instruments are confined principally to forward foreign exchange contracts, interest rate swaps and options. The derivative contracts to hedge risks are not designated as hedges.

Derivatives are initially recognised at fair value on the date a derivative contract is entered into and are subsequently re-measured to their fair value at the end of each reporting period. Net mark to market gains/ losses on derivatives taken by us are recorded in other income/ expenses respectively.

#### **Cash and cash equivalents**

For the purpose of presentation in the restated consolidated statement of cash flows, cash and cash equivalents include cash on hand, demand deposits with banks, other short term highly liquid investments, if any, with original maturities of three months or less that are readily convertible to known amount of cash and subject to an insignificant change in value.

#### **Offsetting financial instruments**

Financial assets and liabilities are offset and the net amount is reported in our restated consolidated statement of assets and liabilities where there is a legally enforceable right to offset the recognised amounts and there is an intention to settle on a net basis or realise the asset and settle the liability simultaneously. The legally enforceable

right must not be contingent on future events and must be enforceable in the normal course of business and in event of default, insolvency or bankruptcy of us or the counterparty.

### **Government grants**

Grants from the government are recognised at their fair value where there is a reasonable assurance that the grant will be received and we will comply with all attached conditions. Government grants relating to income are deferred and recognised in the restated consolidated statement of profit and loss over the period necessary to match them with the costs that they are intended to compensate and presented within other operating revenue.

### **Inventories**

Inventories are valued at the lower of cost and net realisable value. Cost of raw materials and traded goods comprises cost of purchases. Cost of work-in-progress and finished goods comprises direct materials, direct labour and an appropriate proportion of variable and fixed overhead expenditure, the latter being allocated on the basis of normal operating capacity. Cost of inventories also include all other costs incurred in bringing the inventories to their present location and condition. Costs are assigned to individual items of inventory on the basis of weighted-average cost method. Net realisable value is the estimated selling price in the ordinary course of business less the estimated costs of completion and the estimated costs necessary to make the sale.

### **Revenue recognition**

Revenue shall be recognised to depict the transfer of promised goods or services to customers in an amount that reflects the consideration to which the entity expects to be entitled in exchange for those goods and services.

#### Sales of goods

Sales are recognised when control of the products has been transferred to the buyer, being when the products are dispatched/ delivered to the customer depending on the contract terms. This occurs when the products have been shipped or delivered to the specific location as the case may be, the risk of loss has been transferred, and either the customer has accepted the products in accordance with the sales contract, or we have objective evidence that all criteria for acceptance have been satisfied. Revenue from contract with customers is primarily recorded at a point in time. In few contracts our performance does not create an asset with alternative use to us and we have concluded that it has an enforceable right to payment for performance completed to date. In the said cases, the we transfer control of a good or service over time and, therefore, satisfies a performance obligation and recognises revenue over time. We use the input method to recognise revenue.

We have determined that the input method is the best method for measuring progress for these contracts because there is a direct relationship between the costs incurred by us and the transfer of goods and services to the customer. No element of financing is deemed present as the sales are generally made with a credit term up to 180 days which is consistent with market practice.

#### Revenue is recognised based on the price specified in the contract

Some contracts include multiple deliverables, such as sale of product and certain related services. However, the services are simple, does not include an integration service and could be performed by another party. It is therefore accounted for as a separate performance obligation. Where the contracts include multiple performance obligations, the transaction price will be allocated to each performance obligation based on the stand-alone selling prices. Where these are not directly observable, they are estimated based on the expected cost plus margin. If contracts include the installation of product, revenue for the product is recognized at a point in time when the product is delivered, the legal title has passed and the customer has accepted the product.

A receivable is recognised when the goods are despatched or delivered, depending on the contract terms, as this is the point in time that the consideration is unconditional because only the passage of time is required before the payment is due. A contract asset is recognised in respect of those performance obligations where the control of the goods has been transferred to the buyer, and only delivery of the goods is pending. In these cases the consideration is due after the shipping obligation is complete, accordingly these are classified as contract assets as the consideration is conditional on something other than the passage of time.

We do not have any contracts where the period between the transfer of the promised goods or services to the customer and payment by the customer exceeds one year. As a consequence, we do not adjust any of the transaction prices for the time value of money.

## **Other income**

### Interest

Interest income is calculated by applying the effective interest rate to the gross carrying amount of a financial asset.

### Dividend

Dividend income from investments is recognised when the shareholder's rights to receive payment is established.

## **Borrowing costs**

Borrowing costs include interest, other costs incurred in connection with borrowing and exchange differences arising from foreign currency borrowings to the extent that they are regarded as an adjustment to the interest cost. General and specific borrowing costs directly attributable to the acquisition, construction or production of qualifying assets, are capitalised during the period of time that is required to complete and prepare the assets for its intended use or sale. Qualifying assets are assets that necessarily take a substantial period of time to get ready for their intended use or sale. All other borrowing costs are expensed in the period in which they are incurred.

## **Foreign currencies**

### Functional and presentation currency

Our Restated Consolidated Financial Information are presented in Indian rupees (INR), which is the functional currency of the parent and the presentation currency for the financial information.

### Transaction and balances

Transactions in foreign currencies are translated into the functional currency at exchange rates prevailing on the date of the transaction. Foreign exchange gains and losses resulting from the settlement of such transactions are generally recognised in the restated consolidated statement of profit and loss. Monetary assets and liabilities related to such foreign currency transactions at the end of the period/ year are translated at period/ year end exchange rates and are generally recognised in restated consolidated statement of profit and loss. Non-monetary assets and non-monetary liabilities denominated in a foreign currency and measured at fair value are translated at the exchange rate prevalent at the date when the fair value was determined. Non-monetary assets and non-monetary liabilities denominated in a foreign currency and measured at historical cost are translated at the exchange rate prevalent at the date of transaction.

### Foreign operations

The result and financial position of foreign operations (none of which has the currency of a hyper-inflationary economy) that have a functional currency different from the presentation currency are translated into the presentation currency as follows:

- (a) Assets and liabilities are translated at the closing rate at the date of our restated consolidated statement of assets and liabilities;
- (b) Income and expenses are translated at average exchange rates (unless this is not a reasonable approximation of cumulative effect of the rates prevailing on the transaction dates, in which case income and expenses are translated at the dates of the transactions); and
- (c) All resulting exchange differences are recognised in restated other comprehensive income.

On consolidation, exchange differences arising from the translation of any net investment in foreign entities, are recognised in restated other comprehensive income. Goodwill and fair value adjustments arising on the acquisition of a foreign operation are treated as assets and liabilities of the foreign operation and translated at the exchange rate in effect at the balance sheet date.

## **Employee benefits**

### Short-term employee benefits

Short-term employee benefits (i.e., benefits payable within one year) are recognised in the period in which employee services are rendered.

### Defined contribution plans

Payments to defined contribution plans are charged as an expense as they fall due. Payments made to state managed retirement benefit schemes are dealt with as payments to defined contribution schemes as we have no further payment obligations once the contributions have been paid.

### Defined benefit plans

For defined benefit retirement schemes the cost of providing benefits is determined using the Projected Unit Credit Method, with actuarial valuation being carried out at each balance sheet date. Re-measurement gains and losses of the net defined benefit liability/ (asset) are recognised immediately in restated other comprehensive income. The service cost and net interest on the net defined benefit liability/ (asset) is treated as a net expense within employment costs.

Past service cost is recognised as an expense when the plan amendment or curtailment occurs or when any related restructuring costs or termination benefits are recognised, whichever is earlier. The retirement benefit obligation recognised in our restated consolidated statement of assets and liabilities represents the present value of the defined-benefit obligation as reduced by the fair value plan assets.

### Other long-term employee benefits:

#### Compensated absences

Accumulated compensated absences which are expected to be availed or encashed within 12 months from the period/ year end are treated as short term employee benefits. The obligation towards the same is measured at the expected cost of accumulating compensated absences as the additional amount expected to be paid as a result of the unused entitlements as at the period/ year end.

Accumulated compensated absences which are expected to be availed or encashed beyond 12 months from the period/ year end are treated as other long term employee benefits. Our liability is actuarially determined (using the Projected Unit Credit method) at the end of each period/ year. Actuarial loss/gains are recognised in our restated consolidated statement of profit and loss in the period/ year in which they arise.

#### Share based payments

Share-based compensation benefits are provided to employees via the Tega Industries Limited Employee Stock Option Scheme namely ESOP Scheme 2011. Employees of the Company receive remuneration in the form of share-based payments, whereby employees render services as consideration for equity instruments (equity-settled transactions).

The cost of equity-settled transactions is determined by the fair value at the date when the grant is made using an appropriate valuation model. That cost is recognised, together with a corresponding increase in employee stock options outstanding account in equity, over the period in which the performance and/or service conditions are fulfilled, in employee benefit expense. The cumulative expense recognised for equity-settled transactions at each reporting date until the vesting date reflects the extent to which the vesting period has expired and the Company's best estimate of the number of equity instruments that will ultimately vest. Service and non-market performance conditions are not taken into account when determining the grant date fair value of awards, but the likelihood of the conditions being met is assessed as part of our best estimate of the number of equity instruments that will ultimately vest. Market performance conditions are reflected within the grant date fair value. The dilutive effect of outstanding options is reflected as additional share dilution in the computation of diluted earnings per share.

## **Current and deferred tax**

The current income tax charge is calculated on the basis of the tax laws enacted or substantively enacted at the end of the reporting period in the countries where the Company and its subsidiaries operate and generate taxable

income. Our management periodically evaluates positions taken in tax returns with respect to situations in which applicable tax regulation is subject to interpretation. It establishes provisions where appropriate on the basis of amounts expected to be paid to the tax authorities.

Deferred income tax is provided in full, using the liability method, on temporary differences arising between the tax bases of assets and liabilities and their carrying amounts in our Restated Consolidated Financial Information. However, deferred tax liabilities are not recognised if they arise from the initial recognition of goodwill. Deferred income tax is also not accounted for if it arises from initial recognition of an asset or liability in a transaction other than a business combination that at the time of the transaction affects neither accounting profit nor taxable profit (tax loss). Deferred income tax is determined using tax rates (and laws) that have been enacted or substantially enacted by the end of the reporting period and are expected to apply when the related deferred income tax asset is realised or the deferred income tax liability is settled.

Deferred tax liabilities are not recognised for temporary differences between the carrying amount and tax bases of investments in subsidiaries, branches and interest in joint arrangements where the Group is able to control the timing of the reversal of the temporary differences and it is probable that the differences will not reverse in the foreseeable future.

Deferred tax assets are not recognised for temporary differences between the carrying amount and tax bases of investments in subsidiaries, branches and associates and interest in joint arrangements where it is not probable that the differences will reverse in the foreseeable future and taxable profit will not be available against which the temporary difference can be utilised. Deferred tax assets and liabilities are offset when there is a legally enforceable right to offset current tax assets and liabilities and when the deferred tax balances relate to the same taxation authority. Current tax assets and tax liabilities are offset where the entity has a legally enforceable right to offset and intends either to settle on a net basis, or to realise the asset and settle the liability simultaneously. Current and deferred tax is recognised in restated profit or loss, except to the extent that it relates to items recognised in restated other comprehensive income or directly in equity. In this case, the tax is also recognised in restated other comprehensive income or directly in equity, respectively.

Minimum Alternate Tax (MAT) credit is recognised as an asset only when and to the extent there is convincing evidence that we will pay normal income tax during the specified period. Such asset is reviewed at each Balance Sheet date and the carrying amount of the MAT credit asset is written down to the extent there is no longer a convincing evidence to the effect that we will pay normal income tax during the specified period.

### **Provision, contingent liabilities and contingent assets**

We recognise a provision where there is a present obligation as a result of a past event that probably requires an outflow of resources and a reliable estimate can be made of the amount of the obligation. However, provisions are not recognised for future operating losses. Where there are a number of similar obligations, the likelihood that an outflow will be required in settlement is determined by considering the class of obligations as a whole. A provision is recognised even if the likelihood of an outflow with respect to any one item included in the same class of obligations may be small.

Provisions are measured at the present value of our management's best estimate of the expenditure required to settle the present obligation at the end of the reporting period. The discount rate used to determine the present value is a pre-tax rate that reflects current market assessments of the time value of money and the risks specific to the liability. The increase in the provision due to the passage of time is recognised as interest expense. A disclosure of a contingent liability is made when there is a possible obligation or a present obligation that may, but probably will not, require an outflow of resources or there is a present obligation, reliable estimate of the amount of which cannot be made. Where there is a possible obligation or a present obligation and the likelihood of outflow of resources is remote, no provision or disclosure for contingent liability is made.

#### Provision for warranty

The estimated liability for warranty is recorded when products are sold. These estimates are established using historical information on the nature, frequency and average cost of obligations and management estimates regarding possible future incidence based on corrective actions on product failure.

### **Non-current assets (or disposal groups) held for sale and discontinued operations**

A discontinued operation is a component of the entity that has been disposed of or is classified as held for sale and that represents a separate major line of business or geographical area of operations, is part of a single co-

ordinated plan to dispose of such a line of business or area of operations, or is a subsidiary acquired exclusively with a view to resale. The results of discontinued operations are presented separately in our restated consolidated statement of profit and loss. Non-current assets classified as held for sale and the assets of a disposal group classified as held for sale are presented separately from the other assets in our restated consolidated statement of assets and liabilities. The liabilities of a disposal group classified as held for sale are presented separately from other liabilities in our restated consolidated statement of assets and liabilities.

Non-current assets (or disposal groups) are classified as held for sale if their carrying amount will be recovered principally through a sale transaction rather than through continuing use and a sale is considered highly probable. They are measured at the lower of their carrying amount and fair value less costs to sell, except for assets such as deferred tax assets, assets arising from employee benefits, financial assets and contractual rights under insurance contracts, which are specifically exempt from this requirement.

### **Earnings per Share**

Basic earnings per share is calculated by dividing net profit or loss for the period attributable to equity shareholders by the weighted average number of equity shares outstanding during the period. Earnings considered in ascertaining our earnings per share is the net profit or loss for the period. The weighted average number of equity shares outstanding during the period and for all periods presented is adjusted for events, such as bonus shares, other than the conversion of potential equity shares, if any, that have changed the number of equity shares outstanding, without a corresponding change in resources. For the purpose of calculating diluted earnings per share, the net profit or loss for the period attributable to equity shareholders and the weighted average number of shares outstanding during the period are adjusted for the effects of all dilutive potential equity shares.

### **Segment reporting**

Operating segments are reported in a manner consistent with the internal reporting provided to the chief operating decision maker. The executive committee of the Company assesses the financial performance and our position and they are our chief operating decision maker.

### **Rounding off**

All amounts in the financial statements have been rounded off to the nearest million with two decimal places as per the requirement of Schedule III to the Companies Act, 2013, unless otherwise indicated.

### **Exceptional items**

An exceptional item is an item of income or expense within profit or loss, which is of such size, nature and incidence that its disclosure is relevant to explain our performance for the period. The nature and amount of such item is disclosed separately in our restated consolidated statement of profit and loss.

### **Leases**

#### As lessee

We account for each lease component within the contract as a lease separately from non-lease components of the contract and allocates the consideration in the contract to each lease component on the basis of the relative stand-alone price of the lease component and the aggregate stand-alone price of the non-lease components. We recognise right-of-use asset representing its right to use the underlying asset for the lease term at the lease commencement date. The cost of the right-of-use asset measured at inception comprises of the amount of initial measurement of the lease liability adjusted for any lease payments made at or before the commencement date.

Certain lease arrangements include options to extend or terminate the lease before the end of the lease term. The right-of-use assets and lease liabilities include these options when it is reasonably certain that such options would be exercised. The right-of-use assets is subsequently measured at cost less any accumulated depreciation, accumulated impairment losses, if any and adjusted for any re-measurement of the lease liability. The right-of-use assets is depreciated using the straight-line method from the commencement date over the shorter of lease term or useful life of right-of-use asset. Right-of-use assets are tested for impairment whenever there is any indication that their carrying amounts may not be recoverable. Impairment loss, if any, is recognized in our restated consolidated statement of profit and loss.

Lease liability is measured at the present value of the lease payments that are not paid at the commencement date of the lease. The lease payments are discounted using the interest rate implicit in the lease, if that rate can be readily determined. If that rate cannot be readily determined, we use the incremental borrowing rate. The lease liability is subsequently re-measured by increasing the carrying amount to reflect interest on the lease liability, reducing the carrying amount to reflect the lease payments made and re-measuring the carrying amount to reflect any reassessment or lease modifications. We recognize the amount of the re-measurement of lease liability as an adjustment to the right-of-use asset. Where the carrying amount of the right-of-use asset is reduced to zero and there is a further reduction in the measurement of the lease liability, we recognize any remaining amount of the re-measurement in our statement of restated consolidated profit and loss.

Variable lease payments not included in the measurement of the lease liabilities are expensed to our restated consolidated statement of profit and loss in the period in which the events or conditions which trigger those payments occur.

### IPO Expenses

The transaction costs incurred by the Holding Company on behalf of the selling shareholders, with respect to the proposed IPO, is recognised as an asset, being recoverable from the selling shareholders.

### Non-GAAP Financial Measures

In addition to our results determined in accordance with Ind AS, we believe certain Non-GAAP measures are useful to investors in evaluating our operating performance. We use these Non-GAAP financial information to evaluate our ongoing operations and for internal planning and forecasting purposes. We believe that Non-GAAP financial information, when taken collectively with financial measures prepared in accordance with Ind AS, may be helpful to investors because it provides an additional tool for investors to use in evaluating our ongoing operating results and trends and in comparing our financial results with other companies in our industry because it provides consistency and comparability with past financial performance. However, our management does not consider these Non-GAAP measures in isolation or as an alternative to financial measures determined in accordance with Ind AS.

Non-GAAP financial information is presented for supplemental informational purposes only, has limitations as an analytical tool and should not be considered in isolation or as a substitute for financial information presented in accordance with Ind AS. Non-GAAP financial information may be different from similarly-titled Non-GAAP measures used by other companies. The principal limitation of Non-GAAP financial measures is that they exclude significant expenses and income that are required by Ind AS to be recorded in our financial statements. In addition, they are subject to inherent limitations as they reflect the exercise of judgment by management about which expenses and income are excluded or included in determining these Non-GAAP financial measures.

### Summary of Results of Operations

The following is a summary of our profit and loss account as per our Restated Consolidated Financial Information for the periods indicated:

Particulars	For three months period ended 30 June 2021		Fiscal 2021		Fiscal 2020		Fiscal 2019	
	in ₹ million	% of total income	in ₹ million	% of total income	in ₹ million	% of total income	in ₹ million	% of total income
<b>Income</b>								
Revenue from Operations	1,732.07	96.56	8,055.22	94.03	6,848.47	98.46	6,337.57	98.56
Other Income	61.79	3.44	511.62	5.97	106.95	1.54	92.56	1.44
<b>Total Income</b>	<b>1,793.86</b>	<b>100.00</b>	<b>8,566.84</b>	<b>100.00</b>	<b>6,955.42</b>	<b>100.00</b>	<b>6,430.13</b>	<b>100.00</b>
<b>Expenses</b>								
Cost of materials consumed	764.32	42.61	3,282.36	38.31	2,847.43	40.94	2,650.29	41.22
Changes in inventories of finished goods and work-in-progress	(78.85)	(4.40)	(44.46)	(0.52)	(109.07)	(1.57)	(76.46)	(1.19)
Employee benefits expense	350.25	19.52	1,226.70	14.32	1,153.34	16.58	1,113.91	17.32
Finance costs	36.13	2.01	172.78	2.02	214.39	3.08	236.02	3.67



Particulars	For three months period ended 30 June 2021		Fiscal 2021		Fiscal 2020		Fiscal 2019	
	in ₹ million	% of total income	in ₹ million	% of total income	in ₹ million	% of total income	in ₹ million	% of total income
Depreciation and amortisation expenses	105.00	5.85	401.80	4.69	383.55	5.51	377.55	5.87
Other expenses	461.34	25.72	1,715.82	20.03	1,891.44	27.19	1,682.36	26.16
<b>Total expenses</b>	<b>1638.19</b>	<b>91.32</b>	<b>6,755.00</b>	<b>78.85</b>	<b>6,381.08</b>	<b>91.74</b>	<b>5,983.67</b>	<b>93.06</b>
<b>Restated Profit before share of restated net profit of joint venture accounted for using equity method and tax</b>	<b>155.67</b>	<b>8.68</b>	<b>1,811.84</b>	<b>21.15</b>	<b>574.34</b>	<b>8.26</b>	<b>446.46</b>	<b>6.94</b>
Share of restated net profit of joint venture accounted for using the equity method	6.16	0.34	26.78	0.31	18.09	0.26	18.09	0.28
<b>Restated Profit before tax</b>	<b>161.83</b>	<b>9.02</b>	<b>1,838.62</b>	<b>21.46</b>	<b>592.43</b>	<b>8.52</b>	<b>464.55</b>	<b>7.22</b>
Income Tax expense:								
- Current Tax	69.67	3.88	372.81	4.35	154.89	2.23	155.96	2.43
- Deferred Tax	(26.66)	(1.49)	101.76	1.19	(217.50)	(3.13)	(18.11)	(0.28)
<b>Total tax expense/ (credit)</b>	<b>43.01</b>	<b>2.40</b>	<b>474.57</b>	<b>5.54</b>	<b>(62.61)</b>	<b>(0.90)</b>	<b>137.85</b>	<b>2.14</b>
<b>Restated total Profit for the period/year (A)</b>	<b>118.82</b>	<b>6.62</b>	<b>1,364.05</b>	<b>15.92</b>	<b>655.04</b>	<b>9.42</b>	<b>326.70</b>	<b>5.08</b>
<b>Restated Other Comprehensive Income/ (loss) (OCI)</b>								
<b>Items that will not be reclassified to profit or loss</b>								
Re-measurement gain/ (loss) on post-employment defined benefit plans	(2.40)	(0.13)	3.11	0.04	(6.36)	(0.09)	(4.87)	(0.08)
Income tax related to above	0.60	0.03	(0.78)	(0.01)	2.22	0.03	1.70	0.03
Share of restated other comprehensive income/ (loss) of joint ventures accounted using the equity method	(0.05)	0.00	0.03	0.00 <sup>^</sup>	(0.02)	0.00 <sup>^</sup>	(0.75)	(0.01)
<b>Items that will be reclassified to profit/ (loss)</b>								
Exchange differences on translation of foreign operations	57.33	3.20	138.27	1.61	(45.11)	(0.65)	(84.49)	(1.31)
<b>Restated Other comprehensive income/ (loss) for the period/year, net of tax (B)</b>	<b>55.48</b>	<b>3.09</b>	<b>140.63</b>	<b>1.64</b>	<b>(49.27)</b>	<b>(0.71)</b>	<b>(88.41)</b>	<b>(1.37)</b>
<b>Restated Total comprehensive income for the</b>	<b>174.30</b>	<b>9.72</b>	<b>1,504.68</b>	<b>17.56</b>	<b>605.77</b>	<b>8.71</b>	<b>238.29</b>	<b>3.71</b>

Particulars	For three months period ended 30 June 2021		Fiscal 2021		Fiscal 2020		Fiscal 2019	
	in ₹ million	% of total income	in ₹ million	% of total income	in ₹ million	% of total income	in ₹ million	% of total income
period/ year (A+B)								
Restated Earnings per equity share (Nominal value per equity share of ₹ 10)								
- Basic (in ₹)	2.10	-	24.10	-	11.57	-	5.76	-
- Diluted (in ₹)	1.78	-	20.48	-	9.84	-	4.90	-

^Amount is below the rounding off norm adopted

## Components of Income and Expenditure

### Total Income

Our total income comprises our revenue from operations and other income.

### Revenue from operations

Our revenue from operations comprises sale of products, sale of services, and other operating revenues.

Our revenue from sale of products accounted for 91.30%, 90.32%, 93.54% and 92.59% of our total income for the three months period ended June 30, 2021 and Fiscals 2021, 2020 and 2019, respectively. Our revenue from sale of services accounted for 3.22%, 1.54%, 1.92% and 2.97% of our total income for the three months period ended June 30, 2021 and Fiscals 2021, 2020 and 2019, respectively.

Our other operating revenues accounted for 2.04%, 2.17%, 3.00% and 3.00% of our total income for the three months period ended June 30, 2021 and Fiscals 2021, 2020 and 2019, respectively. Our other operating revenues comprise revenue from sale of scrap, commission income in relation to sales and marketing support for our joint venture, Hosch India, duty drawback and other export incentives and service fees.

Particulars	For three months period ended 30 June 2021		Fiscal 2021		Fiscal 2020		Fiscal 2019	
	in ₹ million	% of Total revenue from operations	in ₹ million	% of Total revenue from operations	in ₹ million	% of Total revenue from operations	in ₹ million	% of Total revenue from operations
Sale of products (A)	1,637.79	94.56	7,737.28	96.05	6,506.37	95.00	5,953.42	93.94
Sale of services (B)	57.72	3.33	131.82	1.64	133.66	1.95	191.00	3.01
Other operating revenue (C)	36.56	2.11	186.12	2.31	208.44	3.05	193.15	3.05
<b>Total Revenue from operations (A+B+C)</b>	<b>1,732.07</b>	<b>100.00</b>	<b>8,055.22</b>	<b>100.00</b>	<b>6,848.47</b>	<b>100.00</b>	<b>6,337.57</b>	<b>100.00</b>

### Other income

Our other income accounted for 3.44%, 5.97%, 1.54% and 1.44% of our total income for the three months period ended June 30, 2021 and Fiscals 2021, 2020 and 2019, respectively.

Our other income comprises interest income on financial instruments (measured at amortized cost), interest income on income tax refund, dividend income from investments, net fair value gain on investments, net gain on sale of investments, mark-to-market profit on derivative instruments, liabilities/ provisions no longer required written back, a one-time government grant received on account of Covid-19 in Fiscal 2021, net gain on foreign currency transaction and translation and miscellaneous receipts. All the afore-mentioned are non-recurring in nature.

## Expenses

### *Cost of materials consumed*

Our cost of materials consumed comprises cost of raw materials.

The following table sets out the cost of our materials consumed as a percentage of our total income for the periods indicated:

Particulars	For three months period ended June 30, 2021		Fiscal 2021		Fiscal 2020		Fiscal 2019	
	in ₹ million	% of total income	in ₹ million	% of total income	in ₹ million	% of total income	in ₹ million	% of total income
Cost of materials consumed	764.32	42.61	3,282.36	38.31	2,847.43	40.94	2,650.29	41.22

### *Change in inventories of finished goods and work in progress*

Our change in inventories of finished goods and work-in-progress indicate the difference between our opening and closing inventory of, finished goods and work-in-progress, and the exchange difference. Change in inventories of finished goods and work-in-progress accounted for (4.40)%, (0.52)%, (1.57)% and (1.19)% of our total income for the three months period ended June 30, 2021 and Fiscals 2021, 2020 and 2019, respectively.

### *Employee benefits expense*

Employee benefits expense primarily comprise salary and wages, contributions to provident and other funds and staff welfare expenses. Employee benefits expense accounted for 19.52%, 14.32%, 16.58% and 17.32% of our total income for the three months period ended June 30, 2021 and Fiscals 2021, 2020 and 2019, respectively.

### *Finance Costs*

Finance costs comprise (a) interest expenses on leases, income tax and others; (b) other borrowing costs; and (c) applicable loss on foreign currency transactions and translations. Finance costs accounted for 2.01%, 2.02%, 3.08% and 3.67% of our total income for the three months period ended June 30, 2021 and Fiscals 2021, 2020 and 2019, respectively.

### *Depreciation and amortisation expenses*

Depreciation and amortisation expense comprises (a) depreciation of property, plant and equipment; (b) depreciation of right of use of asset; and (c) amortisation of intangible assets. Depreciation and amortisation expenses accounted for 5.85%, 4.69%, 5.51% and 5.87% of our total income for the three months period ended June 30, 2021 and Fiscals 2021, 2020 and 2019, respectively.

### *Other expenses*

Other expenses primarily comprised manufacturing expenses (which consisted of expenses in relation to stores, spares and tool consumed, power and fuel, repairs and maintenance towards machinery, building, and others), administrative expenses (which primarily consisted of professional and consultancy charges, rent, travelling expenses, managerial remuneration, insurance charges and others), and selling expenses (which comprised packing and forwarding, warranty expenses, carriage outwards, and sales promotion expenses).

Our other expenses accounted for 25.72%, 20.03%, 27.19% and 26.16% of our total income for the three months period ended June 30, 2021 and Fiscals 2021, 2020 and 2019, respectively.

### *Restated profit before tax*

Our restated profit before tax was ₹161.83 million, ₹1,838.62 million, ₹592.43 million and ₹464.55 million for the three months period ended June 30, 2021 and Fiscals 2021, 2020 and 2019, respectively.

#### ***Tax expenses***

Our tax expenses include current tax and deferred tax.

Our current tax was ₹69.67 million, ₹372.81 million, ₹154.89 million and ₹155.96 million for the three months period ended June 30, 2021 and Fiscals 2021, 2020 and 2019, respectively.

Our deferred tax charge/ (income) was ₹(26.66) million, ₹101.76 million, ₹(217.50) million, and ₹(18.11) million for the three months period ended June 30, 2021 and Fiscals 2021, 2020 and 2019, respectively.

#### ***Restated total profit for the period/year***

Our restated total profit for the period/year was ₹118.82 million, ₹1,364.05 million ₹655.04 million and ₹326.70 million for the three months period ended June 30, 2021 and Fiscals 2021, 2020 and 2019, respectively.

#### ***Restated other comprehensive income/ (loss) for the period/year***

Our restated other comprehensive income/ (loss) for the period/ year was ₹55.48 million, ₹140.63 million, ₹(49.27) million, and ₹(88.41) million for the three months period ended June 30, 2021 and Fiscals 2021, 2020 and 2019, respectively.

#### ***Restated total comprehensive income/(loss) for the period/year***

Our restated total comprehensive income for the period/year was ₹174.30 million, ₹1,504.68 million, ₹605.77 million, and ₹238.29 million for the three months period ended June 30, 2021 and Fiscals 2021, 2020 and 2019, respectively.

Our restated total comprehensive income for the period/year accounted for 9.72%, 17.56%, 8.71% and 3.71% of our total income for the three months period ended June 30, 2021 and Fiscals 2021, 2020 and 2019, respectively.

### **Three months period ended June 30, 2021**

#### **Total Income**

Our total income for the three months period ended June 30, 2021 was ₹1,793.86 million.

#### ***Revenue from operations***

Our revenue from operations for the three months period ended June 30, 2021 was ₹1,732.07 million and accounted for 96.56% of our total income.

#### ***Revenue from sale of products***

Our revenue from sale of products was ₹1,637.79 million and accounted for 91.30% of our total income, for the three months period ended June 30, 2021.

#### ***Revenue from Sale of Services***

Our revenue from sale of services was ₹57.72 million and accounted for 3.22% of our total income in the three months period ended June 30, 2021.

#### ***Other operating revenues***

Our other operating revenue aggregated to ₹36.56 million and accounted for 2.04% of our total income in the three months period ended June 30, 2021.

#### ***Other income***

Our other income was ₹61.79 million and accounted for 3.44% of our total income, in the three months period ended June 30, 2021.

## **Expenses**

### *Cost of materials consumed*

Our cost of materials consumed was ₹764.32 million and accounted for 42.61% of our total income in the three months period ended June 30, 2021.

### *Change in inventories of finished goods and work in progress*

Our stock of finished goods and work-in-progress was ₹700.16 million as on April 1, 2021.

Our stock of finished goods and work-in-progress was ₹787.25 million as on June 30, 2021.

### *Employee benefits expense*

Our employee benefits expense was ₹350.25 million and came to 19.52% of our total income in the three months period ended June 30, 2021.

### *Finance costs*

Our finance costs were ₹36.13 million and accounted for 2.01%, of our total income, for the three months period ended June 30, 2021.

### *Depreciation and amortisation expense*

Our depreciation and amortisation expense was ₹105.00 million and accounted for 5.85% of our total income, for the three months period ended June 30, 2021.

### *Other expenses*

Our other expenses were ₹461.34 million and came to 25.72% of our total income in the three months period ended June 30, 2021.

***Restated profit before tax*** Our restated profit before tax was ₹161.83 million for three months period ended June 30, 2021.

### ***Tax expenses***

Our total tax expense was ₹43.01 million for the three months period ended June 30, 2021.

### ***Restated total profit***

Our restated total profit was ₹118.82 million for the three months period ended June 30, 2021.

Our restated total profit was 6.62%, as a percentage of our total income, for the three months period ended June 30, 2021.

### ***Restated total comprehensive income***

Our restated total comprehensive income was ₹174.30 million for the three months period ended June 30, 2021.

Our restated total comprehensive income came to 9.72%, as a percentage of our total income, for the three months period ended June 30, 2021.

## **Fiscal 2021 compared to Fiscal 2020**

### **Total Income**

Our total income increased by ₹1,611.42 million, or 23.17%, from ₹6,955.42 million in Fiscal 2020 to ₹8,566.84 million in Fiscal 2021, on account of the factors discussed below.

### ***Revenue from operations***

Our total revenue from operations increased by ₹1,206.75 million, or 17.62%, from ₹6,848.47 million in Fiscal 2020 to ₹8,055.22 million in Fiscal 2021. This was primarily attributable to an increase in the sale of products from ₹6,506.37 million in Fiscal 2020 to ₹7,737.28 million in Fiscal 2021. However, such increase was partially offset by a reduction in revenue from sale of services, which decreased from ₹133.66 million in Fiscal 2020 to ₹131.82 million in Fiscal 2021 and a reduction in duty drawback and other export incentives which decreased from ₹158.45 million in Fiscal 2020 to ₹118.79 million in Fiscal 2021.

The reduction in revenue from duty drawback and other export incentives in Fiscal 2021 was on account of a decrease in export incentive on account of the Merchandise Exports From India Scheme (MEIS) benefit being capped between September 2020 and December 2020 and thereafter discontinuation of MEIS from January 1, 2021 and introduced Remission of Duties and Taxes on Export Products (RoDTEP) Scheme, a new export benefit scheme with effect from January 1, 2021, the rates for which were notified on August 17, 2021. This resulted in lower income on account of export benefits.

Further, our revenue from operations from India business increased by ₹152.41 million, or 20.17%, from ₹755.51 million in Fiscal 2020 to ₹907.92 million in Fiscal 2021, while our revenue from operations from outside India increased by ₹1,076.66 million, or 18.30%, from ₹5,884.52 million in Fiscal 2020 to ₹6,961.18 million in Fiscal 2021.

The increase in our revenue from operations from our overseas business was primarily attributable to an increased sale of DynaPrime mill liners in North America and South America; and higher carry over orders from Fiscal 2020 of non DynaPrime mill liners and continuous order flow in Fiscal 2021. This was offset by lower and delayed repeat orders in EMER due to higher life of product supplied.

Further, the increase in our revenue from operations from our domestic business was primarily attributable to increase in sales of mill liners (other than DynaPrime) from project business and non-mill products.

Our revenue from operations accounted for 94.03 % of our total income in Fiscal 2021, compared to 98.46% in Fiscal 2020.

### ***Revenue from sale of products***

Our revenue from sale of products increased by ₹1,230.91 million, or 18.92%, from ₹6,506.37 million in Fiscal 2020 to ₹7,737.28 million in Fiscal 2021, primarily as a result of increase in volume of growth and improved realization.

Our revenue from sale of products accounted for 90.32% of our total income in Fiscal 2021, compared to 93.54% in Fiscal 2020.

### ***Revenue from Sale of Services***

Our revenue from sale of services decreased by ₹1.84 million, or 1.38 %, from ₹133.66 million in Fiscal 2020 to ₹131.82 million in Fiscal 2021, primarily as a result of decline in installation income which is in line with previous Fiscals. This was also due to a one-time project installation order received from certain overseas customers, which had resulted in an increase in installation income in Fiscal 2020.

Our revenue from sale of services accounted for 1.54 % of our total income in Fiscal 2021, compared to 1.92 % in Fiscal 2020.

### ***Other operating revenues***

Our other operating revenues decreased by ₹22.32 million, or 10.71%, from ₹ 208.44 million in Fiscal 2020 to ₹186.12 million in Fiscal 2021. This was primarily as a result of a decrease in export incentive on account of the Merchandise Exports from India Scheme (MEIS) benefit being capped between September 2020 and December 2020 and thereafter discontinuation of MEIS from January 1, 2021, and partially offset by an increase in the sale of scrap and other operating income which consists of service fee and commission income.

Our other operating revenues accounted for 2.17% of our total income in Fiscal 2021, compared to 3.00% in Fiscal 2020.

### ***Other income***

Our other income increased by ₹404.67 million, or 378.37%, from ₹106.95 million in Fiscal 2020 to ₹511.62 million in Fiscal 2021, primarily as a result of increase in net gain on foreign currency transactions and translations of ₹277.40 million, mark to market profit on derivative instruments (net) of ₹61.59 million on derivatives, government grant of ₹42.59 million earned on account of Covid-19 in Fiscal 2021. The net gain on foreign currency transactions and translations was mainly due to the local currency of one of our subsidiaries strengthening against the USD resulting in gains.

The government grant of ₹42.59 million was earned as a one-time grant in Fiscal 2021 on account of Covid-19 in Fiscal 2021 from the governments of various countries in which we operate. These were provided for certain operating expenses such as salaries and wages and in terms of certain interest free borrowings and forgivable loans.

Our other income accounted for 5.97% of our total income in Fiscal 2021, compared to 1.54% in Fiscal 2020.

### **Expenses**

#### *Cost of materials consumed*

Our cost of materials consumed increased by ₹434.93 million, or 15.27 %, from ₹2,847.43 million in Fiscal 2020 to ₹3,282.36 million in Fiscal 2021. This is primarily as a result of increase in the purchase of raw materials consumed on account of higher production resulting from an increase in volume of sales. Such increase was due the overall growth of our business.

Our cost of materials consumed accounted for 38.31% of our total income in Fiscal 2021, compared to 40.94% in Fiscal 2020.

#### *Changes in inventories of finished goods and work in progress*

Inventories of finished goods and work-in-progress at the beginning of the Fiscal year 2020 was ₹511.39 million, while the inventories of finished goods and work-in-progress at the end of Fiscal year 2020 was ₹604.34 million.

Inventories of finished goods and work-in-progress at the beginning of the Fiscal year 2021 was ₹604.34 million, while the inventories of finished goods and work-in-progress at the end of Fiscal year 2021 was ₹700.16 million. The changes in inventories and work in progress was primarily a result of decrease in foreign exchange gain on translation.

#### *Employee benefits expense*

Our employee benefits expense marginally increased by ₹73.36 million, or 6.36%, from ₹1,153.34 million in Fiscal 2020 to ₹1,226.70 million in Fiscal 2021, primarily as a result of increase in the number of employees owing to an increase in operating activities as well as an increase in salaries and wages in Fiscal 2021.

Our employee benefits expense accounted for 14.32% of our total income in Fiscal 2021, compared to 16.58% in Fiscal 2020.

#### *Finance costs*

Our finance costs decreased by ₹41.61 million, or 19.41%, from ₹214.39 million in Fiscal 2020 to ₹172.78 million in Fiscal 2021. This decrease was primarily as a result of decrease in our borrowings, lower utilisation and lower cost of funds during Fiscal 2021.

Our finance costs accounted for 2.02% of our total income in Fiscal 2021, compared to 3.08% in Fiscal 2020.

#### *Depreciation and amortisation expenses*

Our depreciation and amortisation expenses marginally increased by ₹18.25 million, or 4.76%, from ₹383.55 million in Fiscal 2020 to ₹401.80 million in Fiscal 2021, primarily as a result of increase in capital expenditure on property, plant and equipment, leading to higher depreciation.

Our depreciation and amortisation expense accounted for 4.69% of our total income in Fiscal 2021, compared to 5.51% in Fiscal 2020.

### *Other expenses*

Our other expenses decreased by ₹175.62 million, or 9.28%, from ₹ 1,891.44 million in Fiscal 2020 to ₹1,715.82 million in Fiscal 2021. This is primarily as a result of decrease in administrative expenses (primarily due to a decrease in travelling expenses) and selling expenses (primarily due to a decrease in marketing expenses) and no mark-to-market net losses on derivatives.

Our other expenses accounted for 20.03% of our total income in Fiscal 2021, compared to 27.19% in Fiscal 2020.

### *Restated profit before tax*

Our share of restated net profit of joint venture accounted for using the equity method increased by ₹8.69 million, or 48.04%, from ₹18.09 million in Fiscal 2020 to ₹26.78 million in Fiscal 2021, primarily as a result of growth in business.

Our share of restated net profit of joint venture accounted for using the equity method is 0.31% of our total income in Fiscal 2021, compared to 0.26% in Fiscal 2020.

For the reasons discussed above, our restated profit before tax increased by ₹1,246.19 million, or 210.35%, from ₹592.43 million in Fiscal 2020 to ₹1,838.62 million in Fiscal 2021.

Our restated profit before tax accounted for 21.46% of our total income in Fiscal 2021, compared to 8.52% in Fiscal 2020.

### *Tax expenses*

Our total tax expense/ (credit) increased by ₹537.18 million from ₹(62.61) million in Fiscal 2020 to ₹474.57 million in Fiscal 2021. This was driven by an increase in current tax expenses and deferred tax charge in Fiscal 2021. The higher current tax was as a result of the growth in the business, resulting in higher profit, while the higher deferred tax charge was primarily due to reversal of deferred tax asset recognised on the accumulated losses of one of our subsidiaries, Tega Chile in Fiscal 2020, which was reversed on the basis of profits of Tega Chile in Fiscal 2021.

### *Restated total profit for the year*

For the reasons discussed above, our restated total profit for the year increased by ₹709.01 million, or 108.24%, from ₹655.04 million in Fiscal 2020 to ₹1,364.05 million in Fiscal 2021.

Our restated total profit for the year accounted for 15.92% of our total income in Fiscal 2021, compared to 9.42% in Fiscal 2020.

### *Restated total comprehensive income for the year*

Our restated total comprehensive income for the year increased by ₹898.91 million, or 148.39%, from ₹605.77 million in Fiscal 2020 to ₹1,504.68 million in Fiscal 2021, due to the factors discussed above, including an increase in our other income due to net gain on foreign currency transactions and translations.

Our restated total comprehensive income for the year accounted for 17.56% of our total income in Fiscal 2021, compared to 8.71% in Fiscal 2020.

## **Fiscal 2020 compared to Fiscal 2019**

### **Total Income**

Our total income increased by ₹525.29 million, or 8.17%, from ₹6,430.13 million in Fiscal 2019 to ₹6,955.42 million in Fiscal 2020, on account of the factors discussed below.

### *Revenue from operations*

Our total revenue from operations increased by ₹510.90 million, or 8.06%, from ₹6,337.57 million in Fiscal 2019 to ₹ 6,848.47 million in Fiscal 2020. This was primarily attributable to an increase in the sale of products from ₹5,953.42 million in Fiscal 2019 to ₹6,506.37 million in Fiscal 2020 and increase in duty drawback and other export incentives from ₹ 144.53 million in Fiscal 2019 to ₹158.45 million in Fiscal 2020. However, such increase



was partially offset by a reduction in revenue from sale of services, which decreased from ₹191.00 million in Fiscal 2019 to ₹133.66 million in Fiscal 2020.

Further, our revenue from operations from India business increased by ₹50.64 million, or 7.18%, from ₹704.87 million in Fiscal 2019 to ₹755.51 million in Fiscal 2020, while our revenue from operations outside India increased by ₹444.97 million, or 8.18%, from ₹5,439.55 million in Fiscal 2019 to ₹5,884.52 million in Fiscal 2020.

The increase in our revenue from operations outside India was primarily attributable to an increased sale of DynaPrime mill liners in North America, South America and EMER. This was offset by lower and delayed orders in Africa by certain customers and two major mines in Africa under maintenance; and lower revenue from Asia Pacific due to loss of few customers.

Further, the increase in our revenue from operations from India was primarily attributable to increase in sales of non-mill products.

Our revenue from operations accounted for 98.46% of our total income in Fiscal 2020, compared to 98.56 % in Fiscal 2019.

#### *Revenue from sale of products*

Our revenue from sale of products increased by ₹552.95 million, or 9.29%, from ₹5,953.42 million in Fiscal 2019 to ₹6,506.37 million in Fiscal 2020, primarily as a result of increase in the volume of growth.

Our revenue from sale of products accounted for 93.54% of our total income in Fiscal 2020, compared to 92.59% in Fiscal 2019.

#### *Sale of Services*

Our revenue from sale of services decreased by ₹57.34 million, or 30.02%, from ₹191.00 million in Fiscal 2019 to ₹133.66 million in Fiscal 2020, primarily as a result of decline in installation income which is in line with previous Fiscals. This was primarily due to a one-time project installation order received from certain overseas customers in Fiscal 2019.

Our revenue from sale of services accounted for 1.92% of our total income in Fiscal 2020, compared to 2.97% in Fiscal 2019.

#### *Other operating revenues*

Our other operating revenues marginally increased by ₹15.29 million, or 7.92 %, from ₹193.15 million in Fiscal 2019 to ₹208.44 million in Fiscal 2020. This was primarily as a result of an increase in duty drawback and export incentives.

Our other operating revenues accounted for 3.00% of our total income in Fiscal 2020, compared to 3.00% in Fiscal 2019.

#### *Other income*

Our other income increased by ₹14.39 million, or 15.55%, from ₹92.56 million in Fiscal 2019 to ₹106.95 million in Fiscal 2020, primarily as a result of increase in foreign exchange gain (net), an increase in the liabilities no longer required written back and net gain on foreign currency transactions and translations. This was offset by a decrease in the net gain on the sale of investments and a decrease in net mark to market gains on derivatives.

Our other income accounted for 1.54% of our total income in Fiscal 2020, compared to 1.44% in Fiscal 2019.

### **Expenses**

#### *Cost of materials consumed*

Our cost of materials consumed increased by ₹197.14 million, or 7.44%, from ₹2,650.29 million in Fiscal 2019 to ₹2,847.43 million in Fiscal 2020. This is primarily as a result of increase in the purchase of raw materials consumed on account of higher production resulting from an increase in volume of sales. Such increase was due the overall growth of our Company.

Our cost of materials consumed accounted for 40.94% of our total income in Fiscal 2020, compared to 41.22% in Fiscal 2019.

#### *Change in inventories of finished goods and work in progress*

Inventories of finished goods and work-in-progress at the beginning of the Fiscal 2019 was ₹441.26 million while Inventories of finished goods and work-in-progress at the end of the Fiscal 2019 was ₹511.39 million.

Inventories of finished goods and work-in-progress at the beginning of the Fiscal 2020 was ₹511.39 million while Inventories of finished goods and work-in-progress at the end of the Fiscal 2020 it was ₹604.34 million.

The changes in inventories and work in progress were primarily a result of increased production of finished goods and work in progress stock due to an increase in volume of sales.

#### *Employee benefits expense*

Our employee benefits expense marginally increased by ₹39.43 million, or 3.54%, from ₹1,113.91 million in Fiscal 2019 to ₹1,153.34 million in Fiscal 2020, primarily as a result of increase in the number of employees owing to an increase in operating activities as well as an increase in salaries and wages in this period.

Our employee benefits expense accounted for 16.58% of our total income in Fiscal 2020, compared to 17.32% in Fiscal 2019.

#### *Finance costs*

Our finance costs decreased by ₹21.63 million, or 9.16 %, from ₹236.02 million in Fiscal 2019 to ₹214.39 million in Fiscal 2020. This decrease was primarily as a result of decrease in lower cost of fund during this period.

Our finance costs accounted for 3.08% of our total income in Fiscal 2020, compared to 3.67% in Fiscal 2019.

#### *Depreciation and amortisation expenses*

Our depreciation and amortisation expenses increased by ₹6.00 million, or 1.59 %, from ₹377.55 million in Fiscal 2019 to ₹383.55 million in Fiscal 2020, primarily as a result of increase in capital expenditure on property, plant and equipment, leading to higher depreciation.

Our depreciation and amortisation expenses accounted for 5.51% of our total income in Fiscal 2020, compared to 5.87% in Fiscal 2019.

#### *Other expenses*

Our other expenses increased by ₹209.08 million, or 12.43%, from ₹1,682.36 million in Fiscal 2019 to ₹1,891.44 million in Fiscal 2020. This is primarily as a result of increase in mark-to-market net losses on derivatives, increase in foreign exchange losses and increase in the provisions for expected credit losses (ECL).

Our other expenses accounted for 27.19% of our total income in Fiscal 2020, compared to 26.16% in Fiscal 2019.

#### ***Restated profit before tax***

Our share of restated net profit of joint venture accounted for using the equity method remained constant, from ₹18.09 million in Fiscal 2019 to ₹ 18.09 million in Fiscal 2020.

Our share of restated net profit of joint venture accounted for using the equity method is 0.26% of our total income in Fiscal 2020, compared to 0.28% in Fiscal 2019.

For the reasons discussed above, our restated profit before tax increased by ₹127.88 million, or 27.53%, from ₹464.55 million in Fiscal 2019 to ₹592.43 million in Fiscal 2020.

Our restated profit before tax accounted for 8.52% of our total income in Fiscal 2020, compared to 7.22% in Fiscal 2019.

### ***Tax expense***

Our total tax expenses decreased by ₹200.46 million, or 145.42%, from ₹ 137.85 million in Fiscal 2019 to ₹ (62.61) million in Fiscal 2020. This was driven by a decrease in current tax expenses and increase in the deferred tax credit in Fiscal 2020. The deferred tax credit in Fiscal 2020 was primarily due to deferred tax asset recognised on the accumulated losses of one of our subsidiaries, Tega Chile.

### ***Restated total profit for the year***

For the reasons discussed above, our restated total profit for the year increased by ₹328.34 million, or 100.50%, from ₹326.70 million in Fiscal 2019 to ₹655.04 million in Fiscal 2020.

Our restated total profit for the year accounted for 9.42 % of our total income in Fiscal 2020, compared to 5.08 % in Fiscal 2019.

### ***Restated total comprehensive income for the year***

Our restated total comprehensive income for the year increased by ₹367.48 million, or 154.22%, from ₹238.29 million in Fiscal 2019 to ₹605.77 million in Fiscal 2020.

Our restated total comprehensive income for the year accounted for 8.71% of our total income in Fiscal 2020, compared to 3.71% in Fiscal 2019.

### **Financial Condition, Liquidity and Capital Resources**

Historically, we have maintained liquidity for our business operations primarily from the cash generated from operations and bank borrowings. As of June 30, 2021, we had cash and cash equivalents in our operations of ₹645.77 million. From time to time, we may obtain loan facilities to finance our short term working capital requirements. For further information, see “*Management’s Discussion and Analysis of Financial Condition and Results of Operations - Indebtedness*” below. Based on our current level of expenditures, we believe that our current working capital, together with cash flows from operating activities will be adequate to meet our anticipated cash requirements for capital expenditure and working capital for the next 12 months.

### ***Cash Flows***

The following table sets forth selected items from our Restated Consolidated Financial Information-Restated Consolidated Statement of Cash Flows for the periods indicated:

Particulars	Three months period ended 30 June 2021	Fiscal		
		2021	2020	2019
Net cash generated from operating activities	492.35	1,702.46	1,283.75	686.69
Net cash (used in) investing activities	(205.76)	(797.29)	(1,012.97)	(134.21)
Net cash (used in) financing activities	(118.59)	(790.04)	(92.03)	(932.12)
Net increase/ (decrease) in cash and cash equivalents	168.00	115.13	178.75	(379.64)
Cash and cash equivalents as at beginning of period/ year	478.70	368.63	192.64	576.91
Exchange differences on translation of foreign currency cash and cash equivalents	(0.93)	(5.06)	(2.76)	(4.63)
Cash and cash equivalents as at end of period/ year	645.77	478.70	368.63	192.64

### ***Cash flow from operating activities***

Net cash generated from operating activities for three months period ended June 30, 2021 was ₹492.35 million and our restated operating profit before working capital changes for that period was ₹290.39 million. The key adjustments were made to restated operating profit before working capital changes to arrive at cash flow from operating activities:

- (a) Decrease in Non-Current / Current financial and other assets of ₹497.69 million primarily on account decrease in receivables.

- (b) (Increase) in inventories of ₹(491.33) million primarily on account of building up the inventory to ensure adequate material in plant so to take care of production amidst challenges in supply chain due to COVID Pandemic.
- (c) Increase in Non-Current / Current financial and other liabilities/ provisions of ₹247.47 million primarily on account of increase in trade payable.

Net cash generated from operating activities in Fiscal 2021 was ₹1,702.46 million and our restated operating profit before working capital changes for that period was ₹2,390.70 million. The key adjustments were made to restated operating profit before working capital changes to arrive at cash flow from operating activities:

- (a) (Increase) in Non Current/ Current financial and other assets of ₹(396.65) million primarily on account of commensurate increase in revenue from operations.
- (b) (Increase) in inventories of ₹(312.92) million primarily on account of commensurate increase in revenue from operations.
- (c) Increase in Non Current/ Current financial and other liabilities/ provisions of ₹324.69 million primarily on account of acceptance

Net cash generated from operating activities in Fiscal 2020 was ₹1,283.75 million and our restated operating profit before working capital changes for that period was ₹1,358.74 million. The key adjustments were made to restated operating profit before working capital changes to arrive at cash flow from operating activities:

- (a) Decrease in Non Current/ Current financial and other assets of ₹430.51 million primarily on account of improved collections.
- (b) (Increase) in inventories of ₹ (165.18) million primarily on account of commensurate increase in revenue from operations.
- (c) (Decrease) in Non Current/ Current financial and other liabilities/ provisions of ₹(145.07) million primarily on account of lower acceptance.

Net cash generated from operating activities in Fiscal 2019 was ₹686.69 million and our restated operating profit before working capital changes for that period was ₹1,169.35 million.

The key adjustments were made to restated operating profit before working capital changes to arrive at cash flow from operating activities:

- (a) (Increase) in Non Current/ Current financial and other assets of ₹(389.90) million primarily on account of commensurate increase in revenue from operations.
- (b) (Increase) in inventories of ₹(100.18) million primarily on account of commensurate increase in revenue from operations.
- (c) Decrease in Non Current/ Current financial and other liabilities/ provisions of ₹153.70 million primarily on account of trade payables.

#### ***Cash flow from investing activities***

Net cash (used in) investing activities in the three months period ended June 30, 2021 was ₹205.76 million, primarily consisting of purchase of capital assets of ₹93.11 million and payment for purchase of investments of ₹319.98 million. This was partially offset by proceeds from sale of investments of ₹206.93 million, sale of capital assets of ₹1.61 million and interest received of ₹0.95 million.

Net cash (used in) investing activities in Fiscal 2021 was ₹797.29 million, primarily consisting of purchase of capital assets of ₹486.12 million, payment for purchase of investments of ₹1,659.56 million and deposits with bank placed of ₹111.02 million. This was partially offset by proceeds from sale of investments of ₹1,341.46 million, deposits with bank matured of ₹110.06 million, interest received of ₹3.37 million and dividend received of ₹2.25 million.

Net cash (used in) investing activities in Fiscal 2020 was ₹1,012.97 million, primarily consisting of purchase of capital assets of ₹277.99 million, payment for purchase of investments of ₹1,244.30 million and deposits with

bank placed of ₹202.36 million. This was partially offset by proceeds from sale of investments of ₹486.68 million, deposits with bank matured of ₹199.26 million, interest received of ₹5.42 million and dividend received of ₹6.75 million.

Net cash (used in) investing activities in Fiscal 2019 was ₹134.21 million, primarily consisting of purchase of capital assets of ₹261.57 million, payment for purchase of investments of ₹606.96 million and deposits with bank placed of ₹325.19 million. This was partially offset by proceeds from sale of investments of ₹711.96 million, proceeds from the disposal of a subsidiary of ₹7.45 million, deposits with bank matured of ₹326.45 million, interest received of ₹3.86 million and dividend received of ₹2.25 million.

### ***Cash Flow from financing activities***

Net cash (used in) financing activities in the three months period ended June 30, 2021 was ₹118.59 million. This primarily consisted of repayment of long term borrowings of ₹47.75 million, repayment of short-term borrowings (net) of ₹8.27 million, finance cost paid of ₹22.66 million, finance cost paid on account of lease liability of ₹6.54 million and repayment of lease liability of ₹21.88 million.

Net cash (used in) financing activities in Fiscal 2021 was ₹790.04 million. This primarily consisted of repayment of long term borrowings of ₹128.36 million, repayment of short-term borrowings (net) of ₹574.03 million, finance cost paid of ₹110.71 million, finance cost paid on account of lease liability of ₹26.52 million and repayment of lease liability of ₹77.32 million. This was partially offset by ₹171.46 million received as proceeds from long term borrowings.

Net cash (used in) financing activities in Fiscal 2020 was ₹92.03 million. This primarily consisted of repayment of long term borrowings of ₹564.18 million, finance cost paid of ₹168.51 million, finance cost paid on account of lease liability of ₹25.71 million and repayment of lease liability of ₹53.56 million. This was partially offset by ₹697.59 million received as proceeds from long term borrowings and ₹45.48 million received as proceeds from short term borrowings (net).

Net cash (used in) financing activities in Fiscal 2019 was ₹932.12 million. This primarily consisted of repayment of long term borrowings of ₹450.27 million, repayment of short term borrowings (net) of ₹206.81 million, finance cost paid of ₹196.06 million, finance cost paid on account of lease liability of ₹29.23 million and repayment towards lease liability of ₹36.42 million.

### **Indebtedness**

Set forth below is a summary of our Company's aggregate borrowings, in a consolidated basis, as on September 30, 2021 For further information, see "**Financial Indebtedness**" on page 314:

<i>(in ₹ million, unless otherwise specified)</i>		
<b>Category of borrowing</b>	<b>Sanctioned amount</b>	<b>Outstanding amount as on September 30 2021<sup>#</sup></b>
<b>Secured</b>		
Term loans	1242.46	945.87
<b>Working capital facilities</b>		
- Fund based <sup>(1)</sup>	2118.13	793.54
- Non-fund based <sup>(2)</sup>	817.86	1084.96
<b>Unsecured</b>		
Term Loans	58.73	43.35
<b>Total</b>	<b>4237.18</b>	<b>2,867.72</b>

Note: The exchange rates as of September 30, 2021 for the relevant currencies are i) USD = ₹74.23 (Source: FEDAI), ii) CAD = ₹58.33 (Source: FEDAI), iii) CLP = ₹0.09205 (Source: Oanda), iv) ZAR = ₹4.90 (Source: FEDAI), and v) UF= ₹30,088.37 CLP (Source: Central Bank of Chile)

<sup>#</sup>As certified by SDT & Co, Chartered Accountants, by way of their certificate dated November 10, 2021

<sup>#</sup>Includes the vehicle loans availed by our Company as on September 30, 2021

<sup>(1)</sup> Out of this amount ₹ 1,770 million is convertible to non- fund based facilities<sup>3</sup>

<sup>(2)</sup>For the facility from ACF Capital to Tega Industries Chile SpA sanction limit is not ascertainable. As per terms of sanction it is upto the discretion of the ACF Capital for sanctioning limit for the acceptance of the factoring which will be decided on contract to contract basis. Hence, utilized amount of Rs.60.13 million is considered as sanctioned amount above.

The loan agreements that we have entered into with the lenders typically contain certain restrictive covenants that limit our ability to undertake certain types of transactions. Also, see "**Risk Factors – We may not meet our obligations, including financial and other covenants under our debt financing arrangements, which could adversely affect our cash flows, business, results of operations and financial condition.**" on page 49.

## Contingent Liabilities and Capital Commitments

The following table sets forth the principal components of our contingent liabilities and capital commitments:

Particulars	(in ₹ million)			
	As of June 30, 2021	As of March 31, 2021	As of March 31, 2020	As of March 31, 2019
<b>Claims against us not acknowledged as debt</b>				
- Disputed Excise Duty	14.75	14.75	14.75	25.37
- Disputed Service Tax	3.08	3.08	3.08	6.17
- Disputed Income Tax	64.54	64.54	10.45	85.18
- Disputed Sales Tax	6.56	6.56	13.89	26.82
- Disputed ESI Dues	-	-	-	0.31
<b>Other money for which we are contingently liable*</b>				
- Customer claims*	4.05	4.05	4.05	19.74
- Surety in connection with bond executed by a group company**	1.50	1.50	1.50	1.50
<b>Commitment on Capital Account</b>	<b>52.90</b>	<b>56.40</b>	<b>11.20</b>	<b>67.41</b>

\* Extent of eventual liability, against a customer's claims, (not admitted by the Company) for alleged unsatisfactory product performance as may arise, which is currently not ascertainable and no provision in this regard has been considered necessary by the Company;

\*\* Company is a surety in connection with a general bond executed by one of our Group Companies, MM Aqua Technologies Limited for the due despatch of excisable goods for export without payment of duty.

For further information, see “*Financial Statements – Restated Consolidated Financial Information – Annexure V - Note 44A*” on page 285.

## Contractual Obligations and Commitments

Our estimated amount of contracts remaining to be executed on capital account and not provided for amounted to ₹52.90 million as of June 30, 2021, ₹56.40 million as of March 31, 2021, ₹11.20 million as of March 31, 2020 and ₹67.41 million as of March 31, 2019.

## Off-balance Sheet Arrangements

In the ordinary course of business, we do not have any material off-balance sheet arrangements that have or are reasonably likely to have a current or future effect on our financial condition, revenues or expenses, results of operations, liquidity, capital expenditures or capital resources that we believe are material to investors.

## Related Party Transactions

We enter into various transactions with related parties in the ordinary course of business. For further information, see “*Risk Factors - We have entered into transactions with related parties. These or any future related party transactions may potentially involve conflicts of interest and there can be no assurance that we could not have achieved better terms, had such arrangements been entered into with unrelated parties.*” and “*Financial Statements – Restated Consolidated Financial Information – Annexure V – Note No. 46*” on pages 55 and 287, respectively.

## Auditor Qualifications

There are no qualifications in the audit reports that require adjustments in the Restated Consolidated Financial Information.

## Significant Developments after June 30, 2021

Except as set out in this Red Herring Prospectus, to our knowledge, no circumstances have arisen since the date of the last financial statements as disclosed in this Red Herring Prospectus which have materially or adversely affected or are likely to affect, our operations or profitability, or the value of our assets or our ability to pay our material liabilities within the next 12 months.

## Quantitative and Qualitative Disclosure about Market Risks

*General market risk*

Market risk is the risk that changes in market prices, liquidity and other factors could have an adverse effect on realizable fair values or future cash flows. Our activities expose us primarily to the financial risks of changes in foreign currency exchange rates and interest rates.

Also see, “**Risk Factors**” on page 23.

#### *Foreign exchange rate risk*

Changes in currency exchange rates influence our results of operations. We deal with foreign currency bank accounts, trade receivables and contract assets, borrowings, trade payables and is therefore exposed to foreign exchange risk associated with exchange rate movement. We operate internationally and portion of the business is transacted in several currencies and consequently we are exposed to foreign exchange risk from sales overseas and purchases from overseas suppliers in various foreign currencies. Foreign currency exchange rate exposure is partly balanced by purchasing of goods, commodities and services in the respective currencies. We primarily use derivatives to hedge its risk against foreign currency balances of borrowings, trade payables and trade receivables and contract assets. Such exposures are managed within approved policy parameters utilising foreign exchange forward contracts and options. We also have variable interest rate loan in foreign currency. To manage its risk against interest rate movements we have taken an interest rate swap.

Also see, “**Risk Factors**” on page 23.

#### *Interest rate risk*

Interest rate risk results from changes in prevailing market interest rates, which can cause a change in the fair value of fixed-rate instruments and changes in the interest payments of the variable-rate instruments. Our exposure to the risk of changes in market interest rates relates primarily to our long-term debt obligations with floating interest rates. Our main interest rate risk arises from long-term borrowings with variable rates, which expose the us to cash flow interest rate risk. Our fixed rate borrowings are carried at amortised cost. They are therefore not subject to interest rate risk as defined in Ind AS 107, since neither the carrying amount nor the future cash flows will fluctuate because of a change in market interest rates.

Also see, “**Risk Factors**” on page 23.

#### *Credit Risk*

We are exposed to the risk that our counterparties may not comply with their obligations under a financial instrument or customer contract, leading to a financial loss. We are exposed to credit risk from its operating activities (primarily trade receivables and contract assets) including deposits with banks, investments and other financial instruments. We periodically monitors the recoverability and credit risks of its other financial assets including security deposits and other receivables. We mitigate our risk by diversification of bank deposits and investments, and entering into transactions with a customer base largely comprising creditworthy counterparties, however, there can be no assurance that our counterparties may not default on their obligations, which may adversely affect our business and financial condition.

Also see, “**Risk Factors**” on page 23.

#### *Liquidity Risk*

We are exposed to liquidity risk, which is the risk that an entity will encounter difficulty in meeting obligations associated with financial liabilities that are settled by delivering cash or another financial asset. Prudent liquidity risk management implies maintaining sufficient cash and marketable securities and the availability of funding through an adequate amount of committed credit facilities to meet obligations when due and to close out market positions. Due to the dynamic nature of the underlying businesses, our treasury maintains flexibility in funding by maintaining availability under committed credit lines. We monitor rolling forecasts of the Company’s liquidity position and cash and cash equivalents on the basis of expected cash flows.

Also see, “**Risk Factors**” on page 23.

### **Significant Economic Changes that Materially Affected or are likely to Affect Revenue from Operations**

Except as described in this section and in “*Risk Factors*”, “*Industry Overview*” and “*Business*” on pages 23, 108 and 141, respectively, to our knowledge, there are no significant economic changes that materially affected our operations or are likely to affect income from continuing operations.

### **Unusual or infrequent events or transactions**

Except as discussed in this Red Herring Prospectus, there have been no other events or transactions that, to our knowledge, may be described as “unusual” or “infrequent”.

### **Known trends or uncertainties**

To our knowledge, except as we have described in this Red Herring Prospectus, including under this section and under “*Risk Factors*” on page 23, there are no known trends or uncertainties, which we expect to have a material adverse impact on our revenues or income from continuing operations.

### **Expected future changes in relationship between costs and revenues**

Except as described in this section and in “*Risk Factors*” and “*Business*” on pages 23 and 141, respectively, to our knowledge, there is no future relationship between expenditure and income that will have a material adverse impact on our operations and finances.

### **Material increases in net sales or revenue**

Material increases in our net sales or revenue are primarily due to the reasons described in the section “ – *Summary of Results of Operations*” above.

### **Total turnover of each major Industry segment**

For the three months period ended June 30, 2021 and Fiscals 2021, 2020 and 2019, we operated in only a single segment group. Operating segments are reported in a manner consistent with the internal reporting provided to the chief operating decision maker, in accordance with the relevant accounting standards.

### **New Product or Business Segments**

Other than as described above and in “*Business*” on page 141, there are no new products or business segments that have or are expected to have a material impact on our business prospects, results of operations or financial condition.

### **Significant regulatory changes that materially affected or are likely to affect income from continuing operations**

Except as described in “*Risk Factors*” and “*Key Regulations and Policies in India*” on pages 23 and 167, respectively, there have been no significant regulatory changes that have materially affected or are likely to affect our income from continuing operations.

### **The extent to which our business is seasonal**

There is no seasonality in our business.

### **Competitive conditions**

For a description of the competitive conditions in which we operate, see “*Industry Overview*” and “*Business - Competition*” on pages 108 and 166, respectively.

### **Supplier or customer concentration**

We procure certain of our primary raw materials, i.e. carbon black, high grade natural rubber, polyurethane rubber, styrene-butadiene rubber and wear plates from certain key suppliers which are established players in India and overseas. Further, we have a diversified client base with our top 10 customers accounting for 34.19%, 32.62%, 31.31% and 22.51% of our revenue from operations for the three months period ended June 30, 2021 and Fiscals 2021, 2020 and 2019, respectively. However, see, “*Risk Factors - We are dependent on a few key suppliers of*



*certain raw materials and do not have long term contracts or exclusive arrangements with these key suppliers. Accordingly, the loss of, or a significant reduction in supply by, such suppliers could adversely affect our business, financial condition and results of operations” and “Business” on pages 28 and 141, respectively, and the discussion of credit risk in “- Credit Risk ” above.*

**Material developments since the last balance sheet date**

No circumstances have arisen since June 30, 2021, the date of the Restated Consolidated Financial Information disclosed in this Red Herring Prospectus, which materially and adversely affect or are likely to affect the value of our consolidated assets or our ability to pay our material liabilities within the next 12 months.

## SECTION VI: LEGAL AND OTHER INFORMATION

### OUTSTANDING LITIGATION AND OTHER MATERIAL DEVELOPMENTS

Except as stated in this section, there are no outstanding, (i) criminal proceedings; (ii) actions taken by statutory or regulatory authorities; (iii) claims related to direct or indirect taxes, in a consolidated manner; or (iv) material civil litigation as per the Materiality Policy, in each case involving our Company, Subsidiaries, Promoters or Directors (collectively, the “**Relevant Parties**”). Further, except as stated in this section, there are no (i) disciplinary actions including penalties imposed by SEBI or stock exchanges against our Promoters in the last five Financial Years including any outstanding action. Furthermore, except as stated in this section, there is no pending litigation involving our Group Companies, the adverse outcome of which may have a material impact on our Company.

In accordance with the Materiality Policy, any outstanding civil litigation involving the Relevant Parties would be considered ‘material’, if the monetary amount of claim made by or against the Relevant Party in any such outstanding litigation is in excess of 0.5 % of the restated total profit for the year of our Company for Financial Year 2021, being ₹ 6.82 million as per the Restated Consolidated Financial Information or any other outstanding litigation, an adverse outcome of which would materially and adversely affect our Company’s business, operations, prospects, financial position or reputation, irrespective of the amount involved in such litigation.

Except as stated in this section, there are no outstanding material dues to creditors of our Company. In accordance with the Materiality Policy, any outstanding dues to any creditor of our Company would be considered ‘material’ if the amount of such outstanding dues to any creditor is in excess of 5% of the total consolidated trade payables of our Company as at June 30, 2021, being ₹58.72 million as per the Restated Consolidated Financial Information. Further, for outstanding dues to any party which is a micro, small or medium enterprise (“**MSME**”), the disclosure will be based on information available with the Company regarding status of the creditor as defined under Section 2 of the Micro, Small and Medium Enterprises Act, 2006, as amended.

Further, it is clarified that for the purpose of the above, pre-litigation notices received by any of the Relevant Parties from third parties (excluding those notices issued by statutory/regulatory/tax authorities) shall, in any event, not be considered as litigation and accordingly have not been disclosed in this section until such time that the Relevant Parties, as applicable, are impleaded as defendants in litigation proceedings before any judicial forum.

Unless stated to the contrary, the information provided below is as of the date of this Red Herring Prospectus.

#### I. LITIGATION INVOLVING OUR COMPANY

##### A. Outstanding criminal proceedings involving our Company

###### *Criminal proceedings by our Company*

1. Our Company has filed three criminal complaints against Tecpro Systems Ltd., and its management, under the Negotiable Instruments Act, 1881, in relation to dishonor of cheques. The matters are currently pending before the 7th Judicial Magistrate, Alipore. The aggregate amount involved in these matters is approximately ₹2.70 million.

##### B. Outstanding material civil proceedings involving our Company

###### *Civil proceedings by our Company*

1. Our Company has filed an application dated August 31, 2021 before the National Company Law Tribunal, Hyderabad Bench (“**NCLT**”) to initiate corporate insolvency resolution process under the Insolvency and Bankruptcy Code, 2016 against Tata Projects Limited (“**Debtor**”) and such proceedings, the “**Proceedings**”). The Proceedings have been initiated to claim an amount of ₹15.43 million and interest thereon from the Debtor pursuant to invoices raised by our Company for delivery of materials to the Debtor and in this regard our Company had issued a demand notice dated August 17, 2020. The Debtor responded to the said demand notice denying such claims and levying accusations of delayed deliveries on our Company. Our Company has denied these accusations in the Proceeding and the matter is currently pending before the NCLT.

2. Our Company filed a suit dated April 13, 2018, before the First Civil Judge, Senior Division (Alipore) (“**Civil Judge**”) against Autodesk India Pvt. Ltd (“**Autodesk**”) alleging that Autodesk, through its audit, was trying to block the perpetual software licenses acquired by our Company from Autodesk and was coercing our Company to purchase 35 software licenses from it by, amongst others, threatening our Company with legal consequences. Accordingly, our Company sought an ad interim injunction restraining Autodesk from auditing/inspecting the computer system/network of our Company, accessing/intruding into the software systems of our Company or blocking any of the softwares owned by our Company. The Civil Judge passed an order dismissing the injunction application. Subsequently, our Company filed an appeal before the District Court, Alipore (“**District Court**”), wherein the District Court granted an ad interim injunction. Further, our Company filed a suit dated May 16, 2018 before the District Court seeking a declaration, permanent injunction, and damages amounting to ₹10 million. The suit is currently pending before the District Court.
3. Our Company filed a suit dated August 26, 2013, before the High Court of West Bengal at Calcutta (“**High Court**”) against Kaveri Ultra Polymers (P) Ltd (“**Kaveri Polymers**”) alleging that Kaveri Polymers was infringing a patent granted to our Company by manufacturing, using and supplying a product which was identical to the patented invention of our Company, thereby causing huge loss and damage to our Company. Accordingly, our Company is seeking, amongst other reliefs, a declaration, perpetual injunction and damages amounting to ₹10 million. Further, our Company has filed an injunction application before the High Court for restraining Kaveri Polymers from manufacturing, offering, distributing and selling the patented product of our Company. The matter is currently pending before the High Court.

**C. Outstanding actions by statutory or regulatory authorities against our Company**

1. The Inspector of Factories, Kalyani (“**Inspector**”) filed a petition dated June 17, 2010 before the Additional Chief Judicial Magistrate, Kalyani, Nadia (“**Additional CJM**”), against Mehul Mohanka, the then occupier of our manufacturing facility at Kalyani. The Inspector alleged that on an inspection of the said manufacturing facility, he observed violations of various provisions of the Factories Act, 1948 and the West Bengal Factories Rules, 1958, being (i) the height of the safety trip rod rubber mill machine was more than the prescribed height; (ii) the transmission machinery was not fenced; (iii) copy of supplementary report was not on demand; and (iv) register of accident and dangerous occurrences was not updated. The matter is currently pending before the Additional CJM.
2. The Inspector filed a petition dated April 20, 2015 before the Additional CJM, against Aramudhavan Viji Iyengar, the then occupier of our Company’s manufacturing facility at Kalyani. The Inspector alleged that on an enquiry in relation to an accident at the facility wherein a trainee technicians’ left hand thumb was amputated, it was found that our Company did not comply with various provisions of the Factories Act, 1948 and the West Bengal Factories Rules, 1958. The matter is currently pending before the Additional CJM.

**D. Outstanding tax proceedings against our Company**

The details with respect to direct tax and indirect tax proceedings involving our Company are set out below:

S. No	Particulars	Number of cases	Aggregate amount involved (in ₹ million)*
1.	Direct tax	8	192.06
2.	Indirect tax	16	71.72
<b>Total</b>		<b>24</b>	<b>263.78</b>

\* to the extent quantifiable

**II. LITIGATION INVOLVING OUR SUBSIDIARIES**

**A. Outstanding actions by statutory or regulatory authorities involving any of our Subsidiaries**

*Statutory or regulatory action initiated by our Subsidiaries*

*Tega Chile*

1. Tega Chile filed an administrative appeal before the 2<sup>nd</sup> Santiago Labour Court, against the fine imposed by the labour authority, as a consequence of an alleged lack of compliance with the requirements of the termination letter that must be notified to the employees in case of employment termination. The labour authority contended that in case of unilateral termination under section 161 of the Chilean Labour Code (i.e. termination because of Company's needs), the employer must justify the facts that support the application of such legal course of termination. Tega Chile, on the other hand, claimed that such requirement is not included within the formalities required in the Chilean Labour Code, and even though the employer must justify the application of this legal course of termination if the employee litigates on the issue, the termination letter does not need to include such justification, and thus cannot be basis of such a fine. The 2<sup>nd</sup> Santiago Labour Court has so far passed an order dated July 13, 2021, wherein it has admitted the appeal filed by Tega Chile, and has revoked the fine imposed by the labour authority. The matter is pending before the 2<sup>nd</sup> Santiago Labour Court.

***Statutory or regulatory action initiated against our Subsidiaries***

***Tega Chile***

1. Certain employees of Tega Chile, namely Quezada Correa, Cristian Edgardo, Marcela Lizama Conejan, amongst others, approached the 2<sup>nd</sup> Santiago Labour Court, claiming a demand against the unjustified termination of their labour contracts and payment of pending labour obligations from Tega Chile. The matter is currently pending before the 2<sup>nd</sup> Santiago Labour Court.
2. Certain employees of Tega Chile, namely Quezada Correa, Cristian Edgardo, Marcela Lizama Conejan, amongst others, approached the San Miguel Labour Court, claiming a demand against the unjustified termination of their labour contracts and payment of pending labour obligations from Tega Chile. The matter is currently pending before the San Miguel Labour Court.
3. Certain employees of Tega Chile, namely Abarzua Ordenes, Patricio Andres, approached the 2<sup>nd</sup> Santiago Labour Court, claiming a demand against the unjustified termination of their labour contracts and payment of pending labour obligations from Tega Chile. The matter is currently pending before the 2<sup>nd</sup> Santiago Labour Court.
4. Certain employees of Tega Chile, namely Bravo Fuentes, Cristian Marcelo, approached the 1<sup>st</sup> Santiago Labour Court, claiming a demand against the unjustified termination of their labour contracts and payment of pending labour obligations from Tega Chile. The matter is currently pending before the 1<sup>st</sup> Santiago Labour Court.

**III. LITIGATION INVOLVING OUR PROMOTERS**

**A. Outstanding actions by statutory or regulatory authorities against our Promoters**

***Mehul Mohanka***

1. For details in relation to the petition dated June 17, 2010, filed by Inspector before the Additional CJM against Mehul Mohanka, please refer to “*-Litigation involving our Company- Outstanding action by statutory or regulatory authorities against our Company*” above.

**B. Outstanding tax proceedings involving our Promoters**

S. No	Particulars	Number of cases	Aggregate amount involved (in ₹ million)*
<i>Madan Mohan Mohanka</i>			
1.	Direct tax	2	0.22
<i>Manju Mohanka</i>			
2.	Direct tax	2	0.18
<i>Manish Mohanka</i>			
3.	Direct tax	5	0.40
<i>Mehul Mohanka</i>			
4.	Direct tax	7	2.49
<i>Nihal Fiscal Services Pvt. Ltd</i>			
5.	Direct tax	5	18.93
<b>Total</b>		<b>21</b>	<b>22.22</b>

\* to the extent quantifiable

#### IV. LITIGATION INVOLVING OUR DIRECTORS

##### A. Outstanding actions by statutory or regulatory authorities against any of our Directors

###### *Mehul Mohanka*

1. For details in relation to the petition dated June 17, 2010, filed by Inspector before the Additional CJM against Mehul Mohanka, please refer to “-*Litigation involving our Company- Outstanding action by statutory or regulatory authorities against our Company*” above.

##### B. Outstanding tax proceedings involving our Directors

S. No	Particulars	Number of cases	Aggregate amount involved (in ₹ million)*
<i>Madan Mohan Mohanka</i>			
1.	Direct tax	2	0.22
<i>Mehul Mohanka</i>			
2.	Direct tax	7	2.49
<b>Total</b>		<b>9</b>	<b>2.71</b>

##### Outstanding dues to creditors

As per the Materiality Policy, creditors to whom an amount exceeding ₹58.72 million, which is 5% of the total consolidated trade payables of our Company as on June 30, 2021, as per the Restated Consolidated Financial Information, were considered ‘material’ creditors. Based on the above, there are two (2) material creditors of our Company as at June 30, 2021 to whom an aggregate amount of ₹236.32 million was outstanding. Based on this criterion, details of outstanding dues (trade payables) owed to micro, small and medium enterprises (as defined under Section 2 of the Micro, Small and Medium Enterprises Development Act, 2006), material creditors and other creditors, as on June 30, 2021 by our Company, are set out below:

Type of creditors	Number of creditors	Amount involved* (in ₹ million)
Micro, small and medium enterprises	273	38.26
Material creditors	2	236.32
Other creditors**	848	899.86
<b>Total</b>	<b>1,123</b>	<b>1,174.44</b>

\* All the Figures of creditors have been rounded off to the nearest Million (with two places of decimal).

\*\* Provision for creditor ₹145.20 Million includes:

- IND AS adjustments of ₹(27.04) Million as per Restated Consolidated Financial Information.
- For the calculation of number of other creditors, provision is not considered.

The details pertaining to net outstanding dues towards our material creditors as on June 30, 2021 (along with the names and amounts involved for each such material creditor) are available on the website of our Company at <http://tegaindustries.com/Investorrelations/materialcreditors>. It is clarified that such details available on our website do not form a part of this Red Herring Prospectus.

##### Material developments since the last balance sheet date

Except as stated in “*Management’s Discussion and Analysis of Financial Condition and Results of Operation – Material developments since the last balance sheet date*” on page 354, no circumstances have arisen since June 30, 2021, the date of the Restated Consolidated Financial Information disclosed in this Red Herring Prospectus, which materially and adversely affect or are likely to affect the value of our consolidated assets or our ability to pay our material liabilities within the next 12 months.

## GOVERNMENT AND OTHER APPROVALS

Our business operations require various consents, licenses, registrations, permissions and approvals issued by relevant governmental and regulatory authorities under applicable rules and regulations. We have set out below an indicative list of all material consents, licenses, registrations, permissions and approvals obtained by our Company, and our Subsidiaries, as applicable, for the purposes of undertaking their respective business operations. Except as mentioned below, no further material consents, licenses, registrations, permissions and approvals are required to undertake the Offer. Unless otherwise stated herein and in the section “**Risk Factors**” beginning on page 23, these material approvals are valid as of the date of this Red Herring Prospectus. For further details in connection with the regulatory and legal framework within which we operate, see “**Key Regulations and Policies in India**” beginning on page 167.

We have also set out below, (i) material approvals or renewals applied for but not received; (ii) material approvals expired and renewal yet to be applied for; and (iii) material approvals required but not obtained or applied for, as on the date of this Red Herring Prospectus.

### I. Material approvals obtained in relation to the Offer

For further details on corporate and other approvals in relation to the Offer, see “**Other Regulatory and Statutory Disclosures – Authority for the Offer - Corporate Approvals**” on page 362.

### II. Material approvals obtained in relation to our business

#### A. Incorporation details of our Company and our Material Subsidiaries

1. Certificate of incorporation dated May 15, 1976 issued to our Company by the RoC in the name of, “Tega India Limited”.
2. Certificate for commencement of business dated May 28, 1976 issued to our Company by the RoC in the name of, “Tega India Limited”.
3. Fresh certificate of incorporation dated February 1, 2002 issued to our Company by the RoC, consequent to the change in the name of our Company from “Tega India Limited” to “Tega Industries Limited”.
4. Certificate of incorporation dated November 8, 1984 issued to Tega Africa by the erstwhile Companies and Intellectual Property Commission.
5. Certificate for commencement of business dated November 8, 1984 issued to Tega Africa by the erstwhile Companies and Intellectual Property Commission.
6. Certificate of incorporation dated February 5, 1990 issued to Tega Chile by the Internal Revenue Service.
7. Certificate for commencement of business dated February 5, 1990 issued to Tega Chile by the Internal Revenue Service.
8. Certificate of incorporation dated December 1, 2010 issued to Tega Holdings Pte by the Accounting and Corporate Regulatory Authority.
9. Certificate of incorporation dated July 26, 2001 issued to Losugen by the Australian Securities and Investment Commission.

#### B. Material approvals obtained by our Company

##### (i) Material approvals in relation to our business operations

Material approvals in relation to our manufacturing facilities located at (i) Kalyani, West Bengal; (ii) Samali, West Bengal; and (iii) Dahej, Gujarat:

S.no.	Particulars	Relevant authority/ legislation	Date of expiry			
			Dahej, Gujarat	Kalyani, Bengal	West Bengal	Samali, West Bengal
1.	Factory license	Factories Act and relevant state factories rules	December 31, 2022	December 31, 2021	December 31, 2021	

S.no.	Particulars	Relevant authority/ legislation	Date of expiry			
			Dahej, Gujarat	Kalyani, Bengal	West Bengal	Samali, West Bengal
2.	Consent to establish	Air Act, Water Act and rules thereunder	February 14, 2024	April 30, 2025	March 31, 2022	
3.	Consent to operate	Air Act, Water Act and rules thereunder	February 14, 2024	April 30, 2025	March 31, 2022	
4.	Authorisation for generation, storage and disposal of hazardous wastes	Hazardous and other Wastes (Management and Transboundary Movement) Rules, 2016	February 14, 2024	March 31, 2022	Application pending*	
5.	No objection certificate	Fire department of the local municipal corporations of the respective states	Application pending*	Application pending*	March 31, 2022	
6.	Letter of approval for continued operations in special economic zones (for our manufacturing facility located at Dahej, Gujarat)	Office of Development Commissioner, Ministry of Commerce and Industry, Government of India	September 4, 2023	-	-	

\* For details of pending applications, see, '-Material approvals applied for, but not received' below.

### C. Tax and employment laws related approvals

1. Certificate of registration issued under the EPF Act.
2. Certificate of registration issued under the ESI Act.
3. Certificate of registration under the Contract Labour (Regulation & Abolition) Act, 1970.
4. Registration certificate issued under the relevant shops and establishment.act obtained by our Company
5. GST registrations for payments under various central and state goods and services tax legislations
6. PAN and TAN issued by the Income Tax Department under the IT Act.
7. Professional tax registrations under the applicable state specific laws obtained by our Company.
8. Certificate of Importer Exporter Code issued by the Ministry of Commerce and Industry, Government of India to our Company

### D. Material approvals obtained by our Material Subsidiaries

Each of our Material Subsidiaries have obtained such governmental and/or statutory approvals and other authorizations, licenses, consents/permits from the relevant federal, state, local governmental or regulatory authorities/agencies having jurisdiction over such Material Subsidiaries, for the conduct of its business operations, including those relating to manufacturing, distributing and selling its products, amongst others.

### III. Material approvals applied for, but not received

Certain material consents, licenses, registrations, permissions and approvals that are required to be obtained by our Company for undertaking its business have elapsed in their normal course and our Company has either made an application to the relevant Central Government or state government authorities for renewal of such material consents, licenses, registrations, permissions and approvals or is in the process of making such applications. The material consents, licenses, registrations, permissions and approvals for which applications have been made by our Company include:

1. Application for renewal of trade license for the manufacturing facility located in Kalyani, West Bengal.
2. Application for renewal of authorization for generation, storage and disposal of hazardous wastes for the manufacturing facility located in Samali, West Bengal.

3. Application to the relevant labour commissionerate for renewal of the Shops and Establishment registration for our Company.

#### IV. Material approvals not applied for

Except as stated below, there are no material consents, licenses, registrations, permissions and approvals for which applications are yet to be made by our Company:

Nil

#### Intellectual property related approvals

Our Company has registered our name and/or logo,  in 12 foreign jurisdictions including, the European Union, Canada, South Africa, Chile, and Australia with the relevant trademark registration authorities in such jurisdictions. In India, as on date of this Red Herring Prospectus, our Company has registered several trademarks, including word marks and device marks, under various classes such as class 6, 7, 17, 35, 37 and 42 with the Registrar of Trademarks under the Trademarks Act. In addition, several applications for registration of trademarks have been filed by us in India which are pending.

Further, as on date of this Red Herring Prospectus, we have been granted 8 patents in relation to our products, details of which are set out below. Also have 4 pending patent applications submitted before the Office of the Controller General of Patents in India.

Particulars	Patent registration number	Entity	Country of registration	Validity
Improved screen panel	352307	Company	India	May 20, 2030
Mosaic liner for chute/ Hopper lining	356469	Company	India	July 25, 2033
Improved screen panel and fixing arrangements therefor	231453	Company	India	March 27, 2022
Improved screen panel	9149841	Company	United States	May 20, 2030
Improved screen panel	BR 112012029 345-1	Company	Brazil	March 20, 2031
Improved screen panel	2012/08604	Company	South Africa	November 14, 2032
Ceramic chute liner	2015/07279	Company	South Africa	July 22, 2033
Mosaic liner for chute/ Hopper lining	2016/00190	Company	South Africa	September 8, 2033



## OTHER REGULATORY AND STATUTORY DISCLOSURES

### Authority for the Offer

#### Corporate Approvals

Our Board has approved the Offer pursuant to the resolution passed at its meeting held on April 30, 2021. Further, our Board has taken on record the consent for the Offer for Sale by the Selling Shareholders pursuant to its resolution dated August 16, 2021.

Our Board has pursuant to the resolution passed at its meeting held on November 23, 2021 approved this Red Herring Prospectus for filing with the RoC.

#### Approvals from the Selling Shareholders

Each of the Selling Shareholders have, severally and not jointly, confirmed and authorised the transfer of their respective proportion of the Offered Shares pursuant to the Offer for Sale, as set out below:

S. No.	Name of the Selling Shareholder	Date of consent letter and corporate authorization, if applicable <sup>^</sup>	Maximum number of Offered Shares
<b>Promoter Selling Shareholders</b>			
	Madan Mohan Mohanka	August 16, 2021	3,314,657
	Manish Mohanka	August 16, 2021	662,931
<b>Investor Selling Shareholder</b>			
	Wagner Limited	Consent letter dated August 16, 2021 and resolution dated August 6, 2021	9,691,890*
<b>Total</b>			<b>13,669,478</b>

<sup>^</sup>Each Selling Shareholder, severally and not jointly, confirms that, as required under Regulation 8 of the SEBI ICDR Regulations, they have held the Equity Shares proposed to be offered and sold by them in the Offer or in the case of Wagner Limited, the CCPP that has converted into its portion of the Offered Shares, for a period of at least one year prior to the date of filing of the Draft Red Herring Prospectus. Therefore, the Equity Shares that will be offered by it in the Offer for Sale are eligible to be offered for sale in the Offer. For details, see "Capital Structure" on page 79.

\*Pursuant to resolutions dated November 10, 2021 passed by our Board and Shareholders, 8,692,281 CCPP held by Wagner Limited were converted to 8,692,281 Equity Shares, For details, see "Capital Structure- Notes to the Capital Structure – Equity Share capital history of our Company" and "Capital Structure - Notes to the Capital Structure – Preference Share capital history of our Company" on pages 79 and 82.

#### In-principle Listing Approvals

Our Company has received in-principle approvals from the BSE and NSE for the listing of our Equity Shares pursuant to its letter dated September 2, 2021 and September 8, 2021, respectively.

### Prohibition by the SEBI, the RBI or Governmental Authorities

None of our Company, our Subsidiaries, our Promoters, members of Promoter Group, our Directors or persons in control of our Company and each of the Selling Shareholders are prohibited or debarred from accessing or operating in the capital market or restrained from buying, selling or dealing in securities under any order or direction passed by the SEBI or any securities market regulator in any other jurisdiction or any other authority or court.

Neither our Promoters nor our Directors are promoters or directors of companies which are debarred from accessing the capital markets by the SEBI.

Except for options granted under the ESOP Schemes, there are no outstanding warrants, options or rights to convert debentures, loans or other instruments convertible into, or which would entitle any person any option to receive Equity Shares, as on the date of this Red Herring Prospectus.

Our Promoters or Directors have not been declared as Fugitive Economic Offenders.

Neither our Company nor our Directors or Promoters have been declared as a 'wilful defaulter', as defined under the SEBI ICDR Regulations.

## Directors associated with the Securities Market

None of our Directors or entities with which our Directors are associated, are associated with the securities market in any manner including securities market related business. There has been no action initiated by SEBI against the Directors of our Company in the five years preceding the date of this Red Herring Prospectus.

## Compliance with the Companies (Significant Beneficial Owners) Rules, 2018

Our Company, our Promoters, member of Promoter Group and each of the Selling Shareholders, severally and not jointly, confirm that they are in compliance with the Companies (Significant Beneficial Owners) Rules, 2018, as amended, to the extent applicable to them, as on the date of this Red Herring Prospectus.

## Eligibility for the Offer

Our Company is eligible for the Offer in accordance with the eligibility criteria provided in Regulation 6(1) of the SEBI ICDR Regulations, and is in compliance with the conditions specified therein in the following manner:

- our Company has net tangible assets of at least ₹30.00 million, calculated on a restated and consolidated basis, in each of the preceding three full years (of 12 months each), of which not more than 50% are held as monetary assets;
- our Company has an average operating profit of at least ₹150.00 million, calculated on a restated and consolidated basis, during the preceding three years (of 12 months each), with operating profit in each of these preceding three years;
- our Company has a net worth of at least ₹10.00 million in each of the three preceding full years (of 12 months each), calculated on a restated and consolidated basis; and
- there has been no change of name of our Company at any time during the last one year immediately preceding the date of filing of this Red Herring Prospectus.

Set forth below are our Company's operating profit, net tangible assets, monetary assets, monetary assets as a percentage of our net tangible assets and net worth, derived from our Restated Consolidated Financial Information included in this Red Herring Prospectus.

*(₹ in million, unless otherwise stated)*

	Financial year ended as on		
	March 31, 2021	March 31, 2020	March 31, 2019
A. Net tangible assets <sup>(1)</sup>	5,224.96	4,006.82	3,344.57
Operating profit <sup>(2)</sup>	1,473.00	681.78	589.92
Net worth <sup>(3)</sup>	6,137.22	4,624.89	4,011.05

### Notes:

1. 'Net tangible assets' means the sum of all the assets of our Company excluding goodwill, intangible assets and right of use assets reduced by total liabilities excluding lease liability of the Company
2. 'Operating profit' means restated profit before share of restated net profit of joint venture accounted for using equity method and before tax less other income, plus finance costs excluding other comprehensive income
3. 'Net worth' means the aggregate value of the equity share capital, preference share capital and other equity, as per restated consolidated financial information

Our Company has operating profits in each of the Financial Years 2021, 2020 and 2019 in terms of our Restated Consolidated Financial Information.

Our Company confirms that it is in compliance with the conditions specified in Regulation 7(1) of the SEBI ICDR Regulations, to the extent applicable, and will ensure compliance with the conditions specified in Regulation 7(2) of the SEBI ICDR Regulations, to the extent applicable.

Further, in accordance with Regulation 49(1) of the SEBI ICDR Regulations, our Company shall ensure that the number of Allottees under the Offer shall be not less than 1,000, failing which, the entire application money will be refunded forthwith.

Further, our Company confirms that it is not ineligible to make the Offer in terms of Regulation 5 of the SEBI ICDR Regulations, to the extent applicable. Our Company is in compliance with the conditions specified in Regulation 5 of the SEBI ICDR Regulations.

## **DISCLAIMER CLAUSE OF THE SEBI**

**IT IS TO BE DISTINCTLY UNDERSTOOD THAT SUBMISSION OF THE DRAFT RED HERRING PROSPECTUS TO SEBI SHOULD NOT, IN ANY WAY, BE DEEMED OR CONSTRUED THAT THE SAME HAS BEEN CLEARED OR APPROVED BY SEBI. SEBI DOES NOT TAKE ANY RESPONSIBILITY EITHER FOR THE FINANCIAL SOUNDNESS OF ANY SCHEME OR THE PROJECT FOR WHICH THE OFFER IS PROPOSED TO BE MADE OR FOR THE CORRECTNESS OF THE STATEMENTS MADE OR OPINIONS EXPRESSED IN THE RED HERRING PROSPECTUS. THE BRLMs, AXIS CAPITAL LIMITED, HAVE CERTIFIED THAT THE DISCLOSURES MADE IN THE DRAFT RED HERRING PROSPECTUS ARE GENERALLY ADEQUATE AND ARE IN CONFORMITY WITH THE SECURITIES AND EXCHANGE BOARD OF INDIA (ISSUE OF CAPITAL AND DISCLOSURE REQUIREMENTS) REGULATIONS, 2018. THIS REQUIREMENT IS TO FACILITATE INVESTORS TO TAKE AN INFORMED DECISION FOR MAKING AN INVESTMENT IN THE PROPOSED OFFER.**

**IT SHOULD ALSO BE CLEARLY UNDERSTOOD THAT WHILE THE COMPANY IS PRIMARILY RESPONSIBLE FOR THE CORRECTNESS, ADEQUACY AND DISCLOSURE OF ALL RELEVANT INFORMATION IN THE DRAFT RED HERRING PROSPECTUS, THE BRLMs ARE EXPECTED TO EXERCISE DUE DILIGENCE TO ENSURE THAT THE COMPANY DISCHARGES ITS RESPONSIBILITY ADEQUATELY IN THIS BEHALF AND TOWARDS THIS PURPOSE, THE BRLMs, AXIS CAPITAL LIMITED AND JM FINANCIAL LIMITED HAVE FURNISHED TO SEBI, A DUE DILIGENCE CERTIFICATE DATED AUGUST 17, 2021 IN THE FORMAT PRESCRIBED UNDER SCHEDULE V(A) OF THE SECURITIES AND EXCHANGE BOARD OF INDIA (ISSUE OF CAPITAL AND DISCLOSURE REQUIREMENTS) REGULATIONS, 2018, AS AMENDED.**

**THE FILING OF THE DRAFT RED HERRING PROSPECTUS DOES NOT, HOWEVER, ABSOLVE THE COMPANY FROM ANY LIABILITIES UNDER THE COMPANIES ACT, 2013 OR FROM THE REQUIREMENT OF OBTAINING SUCH STATUTORY AND/OR OTHER CLEARANCES AS MAY BE REQUIRED FOR THE PURPOSE OF THE OFFER. SEBI FURTHER RESERVES THE RIGHT TO TAKE UP, AT ANY POINT OF TIME, WITH THE BRLMs, ANY IRREGULARITIES OR LAPSES IN THE DRAFT RED HERRING PROSPECTUS.**

### **Disclaimer from our Company, our Directors, the Selling Shareholders and the BRLMs**

Our Company, our Directors, the Selling Shareholders and the BRLMs accept no responsibility for statements made otherwise than in this Red Herring Prospectus or in the advertisements or any other material issued by or at our Company's instance and anyone placing reliance on any other source of information, including our Company's website [www.tegainindustries.com](http://www.tegainindustries.com), or any website of any of our Subsidiaries, any affiliate of our Company, any of the Group Companies or any of the Selling Shareholders, would be doing so at his or her own risk. It is clarified that neither the Selling Shareholders, nor their respective directors, affiliates, associates and officers, accept and/or undertake any responsibility for any statements made or undertakings provided other than those specifically made or undertaken by such Selling Shareholder in relation to itself and/or the Equity Shares offered by it through the Offer for Sale.

The BRLMs accept no responsibility, save to the limited extent as provided in the Offer Agreement and the Underwriting Agreement to be entered into between the Underwriters, the Selling Shareholders and our Company.

All information shall be made available by our Company and the BRLMs to the public and investors at large and no selective or additional information would be available for a section of the investors in any manner whatsoever, including at road show presentations, in research or sales reports, at Bidding centres or elsewhere.

Investors who Bid in the Offer will be required to confirm and will be deemed to have represented to our Company, the Selling Shareholders, Underwriters and their respective directors, officers, agents, affiliates, and representatives that they are eligible under all applicable laws, rules, regulations, guidelines and approvals to acquire the Equity Shares and will not issue, sell, pledge, or transfer the Equity Shares to any person who is not eligible under any applicable laws, rules, regulations, guidelines and approvals to acquire the Equity Shares. Our Company, the Selling Shareholders, Underwriters and their respective directors, officers, agents, affiliates, and representatives accept no responsibility or liability for advising any investor on whether such investor is eligible to acquire the Equity Shares.

The BRLMs and their respective associates and affiliates may engage in transactions with, and perform services for, our Company, our Subsidiaries, our Group Companies, the Selling Shareholders and their respective affiliates or associates or third parties in the ordinary course of business and have engaged, or may in the future engage, in commercial banking and investment banking transactions with our Company, the Selling Shareholders and their respective affiliates or associates or third parties, for which they have received, and may in the future receive, compensation. As used herein, the term ‘affiliate’ means any person or entity that controls or is controlled by or is under common control with another person or entity.

### **Disclaimer in respect of Jurisdiction**

This Offer is being made in India to persons resident in India, including Indian nationals resident in India, Hindu Undivided Families (“HUFs”), companies, other corporate bodies and societies registered under the applicable laws in India and authorised to invest in equity shares, Indian Mutual Funds registered with the SEBI, Indian financial institutions, commercial banks, regional rural banks, co-operative banks (subject to permission from the RBI), systemically important non-banking financial companies or trusts under the applicable trust laws, and who are authorised under their respective constitutions to hold and invest in equity shares, public financial institutions as specified under Section 2(72) of the Companies Act 2013, venture capital funds, permitted insurance companies and pension funds and, to permitted non-residents including Eligible NRIs, Alternative Investment Funds (“AIFs”), Foreign Portfolio Investors registered with SEBI (“FPIs”) and QIBs. This Red Herring Prospectus does not, however, constitute an offer to sell or an invitation to subscribe to Equity Shares offered hereby, in any jurisdiction to any person to whom it is unlawful to make an offer or invitation in such jurisdiction. Any person into whose possession this Red Herring Prospectus comes is required to inform himself or herself about, and to observe, any such restrictions. Any dispute arising out of this Offer will be subject to the jurisdiction of appropriate court(s) in Kolkata, West Bengal, India only.

No action has been or will be taken to permit a public offering in any jurisdiction where action would be required for that purpose, except that this Red Herring Prospectus has been filed with SEBI for its observations. Accordingly, the Equity Shares represented hereby may not be offered or sold, directly or indirectly, and this Red Herring Prospectus may not be distributed, in any jurisdiction, except in accordance with the legal requirements applicable in such jurisdiction. Neither the delivery of this Red Herring Prospectus, nor any offer or sale hereunder, shall, under any circumstances, create any implication that there has been no change in our affairs or in the affairs of the Selling Shareholders from the date hereof or that the information contained herein is correct as of any time subsequent to this date.

**The Equity Shares offered in the Offer have not been and will not be registered under the U.S. Securities Act or any state securities laws in the United States, and unless so registered, may not be offered or sold within the United States, except pursuant to an exemption from, or in a transaction not subject to, the registration requirements of the U.S. Securities Act and in accordance with any applicable U.S. state securities laws. Accordingly, the Equity Shares are being offered and sold outside the United States in ‘offshore transactions’ as defined in, and in reliance on, Regulation S under the U.S. Securities Act and the applicable laws of the jurisdictions where such offers and sales are made.**

**The Equity Shares have not been and will not be registered, listed or otherwise qualified in any other jurisdiction outside India and may not be offered or sold, and Bids may not be made by persons in any such jurisdiction, except in compliance with the applicable laws of such jurisdiction.**

Bidders are advised to ensure that any Bid from them does not exceed the investment limits or maximum number of Equity Shares that can be held by them under applicable law.

Further, each Bidder where required must agree in the Allotment Advice that such Bidder will not sell or transfer any Equity Shares or any economic interest therein, including any off-shore derivative instruments, such as participatory notes, issued against the Equity Shares or any similar security, other than pursuant to an exemption from, or in a transaction not subject to, the registration requirements of the U.S. Securities Act.

### **Disclaimer Clause of the BSE**

As required, a copy of the Draft Red Herring Prospectus was submitted to BSE. The disclaimer clause as intimated by the BSE to us is as set forth below:

**“BSE Limited (“the Exchange”) has given vide its letter dated September 2, 2021 permission to this Company to use the Exchange’s name in this offer document as one of the stock exchanges on which this**

company's securities are proposed to be listed. The Exchange has scrutinized this offer document for its limited internal purpose of deciding on the matter of granting the aforesaid permission to this Company. The Exchange does not in any manner: -

a) warrant, certify or endorse the correctness or completeness of any of the contents of this offer document; or

b) warrant that this Company's securities will be listed or will continue to be listed on the Exchange; or

c) take any responsibility for the financial or other soundness of this Company, its promoters, its management or any scheme or project of this Company;

and it should not for any reason be deemed or construed that this offer document has been cleared or approved by the Exchange. Every person who desires to apply for or otherwise acquires any securities of this Company may do so pursuant to independent inquiry, investigation and analysis and shall not have any claim against the Exchange whatsoever by reason of any loss which may be suffered by such person consequent to or in connection with such subscription/acquisition whether by reason of anything stated or omitted to be stated herein or for any other reason whatsoever."

#### **Disclaimer Clause of NSE**

As required, a copy of the Draft Red Herring Prospectus was submitted to NSE. The disclaimer clause as intimated by the NSE to us is as set forth below:

"As required, a copy of this Offer Document has been submitted to National Stock Exchange of India Limited (hereinafter referred to as NSE). NSE has given vide its letter Ref.: NSE/LIST/1201 dated September 08, 2021 permission to the Issuer to use the Exchange's name in this Offer Document as one of the Stock Exchanges on which this Issuer's securities are proposed to be listed. The Exchange has scrutinized this draft offer document for its limited internal purpose of deciding on the matter of granting the aforesaid permission to this Issuer. It is to be distinctly understood that the aforesaid permission given by NSE should not in any way be deemed or construed that the offer document has been cleared or approved by NSE; nor does it in any manner warrant, certify or endorse the correctness or completeness of any of the contents of this offer document; nor does it warrant that this Issuer's securities will be listed or will continue to be listed on the Exchange; nor does it take any responsibility for the financial or other soundness of this Issuer, its promoters, its management or any scheme or project of this Issuer.

Every person who desires to apply for or otherwise acquire any securities of this Issuer may do so pursuant to independent inquiry, investigation and analysis and shall not have any claim against the Exchange whatsoever by reason of any loss which may be suffered by such person consequent to or in connection with such subscription /acquisition whether by reason of anything stated or omitted to be stated herein or any other reason whatsoever."

#### **Listing**

The Equity Shares issued through this Red Herring Prospectus are proposed to be listed on BSE and NSE. Applications will be made to the Stock Exchanges for obtaining permission to deal in and for an official quotation of the Equity Shares being issued and sold in the Offer and NSE is the Designated Stock Exchange, with which the Basis of Allotment will be finalised for the Offer.

If the permission to deal in and for an official quotation of the Equity Shares is not granted by the Stock Exchanges, our Company shall forthwith repay, without interest, all monies received from the applicants in pursuance of the Red Herring Prospectus in accordance with applicable law. Our Company shall ensure that all steps for this completion of the necessary formalities for listing and commencement of trading of Equity Shares at the Stock Exchanges are taken within six Working Days of the Bid/ Offer Closing Date or such other period as may be prescribed by the SEBI. If our Company does not allot Equity Shares pursuant to the Offer within six Working Days from the Bid/ Offer Closing Date or within such timeline as prescribed by the SEBI, it shall repay without interest all monies received from Bidders, failing which interest shall be due to be paid to the Bidders at the rate of 15% per annum for the delayed period. However, the respective Selling Shareholders shall not be liable to pay and/ or reimburse any expenses towards refund or any interest thereon in respect to Allotment of their respective proportion of the Offered Shares or otherwise, unless the failure or default or delay, as the case may be, is solely on account of such Selling Shareholder and such liability shall be limited to the extent of their respective Offered Shares.

## **Impersonation**

Attention of the Bidders is specifically drawn to the provisions of sub-section (1) of Section 38 of the Companies Act 2013, which is reproduced below:

“Any person who –

- (a) *makes or abets making of an application in a fictitious name to a company for acquiring, or subscribing for, its securities, or*
- (b) *makes or abets making of multiple applications to a company in different names or in different combinations of his name or surname for acquiring or subscribing for its securities; or*
- (c) *otherwise induces directly or indirectly a company to allot, or register any transfer of, securities to him, or to any other person in a fictitious name,*

*shall be liable for action under section 447.”*

The liability prescribed under Section 447 of the Companies Act 2013 includes imprisonment for a term of not less than six months extending up to 10 years (provided that where the fraud involves public interest, such term shall not be less than three years) and fine of an amount not less than the amount involved in the fraud, extending up to three times of such amount. Further, where the fraud involves an amount less than ₹ 1 million or one per cent of the turnover of the company, whichever is lower, and does not involve public interest, any person guilty of such fraud shall be punishable with imprisonment for a term which may extend to five years or with fine which may extend to ₹5.00 million or with both.

## **Consents**

Consents in writing of: (a) the Selling Shareholders, our Directors, the Chief Financial Officer and Company Secretary, the Compliance Officer, the legal counsel, the bankers to our Company, industry sources, independent chartered accountants, the BRLMs and Registrar to the Offer have been obtained; and (b) the Syndicate Members, Bankers to the Offer/ Escrow Bank, Public Offer Account Bank, Sponsor Bank and Refund Bank to act in their respective capacities, will be obtained. Further, such consents shall not be withdrawn up to the time of delivery of this Red Herring Prospectus and the Prospectus with the SEBI.

Our Company has received written consent of our Statutory Auditors, who hold a valid peer review certificate, to include their name as required under Section 26(5) of the Companies Act 2013 in this Red Herring Prospectus, and as an “expert”, as defined under Section 2(38) of the Companies Act 2013 to the extent and in their capacity as our Statutory Auditors, and in respect of their examination report, dated November 10, 2021 on our Restated Consolidated Financial Information in this Red Herring Prospectus. However, the term “expert” shall not be construed to mean an “expert” as defined under the U.S. Securities Act.

## **Performance *vis-à-vis* Objects – Public or Rights Issues during the Last Five Years**

There have been no public issues, including any rights issues (as defined under the SEBI ICDR Regulations) to the public undertaken by our Company during the five years preceding the date of this Red Herring Prospectus.

## **Commission or Brokerage on Previous Issues in the Last Five Years**

Since this is the initial public offering of the Equity Shares, no sum has been paid or has been payable as commission or brokerage for subscribing to or procuring or agreeing to procure public subscription for any of our Equity Shares in the five years preceding the date of this Red Herring Prospectus.

## **Capital Issues in the Preceding Three Years**

Except as disclosed in “*Capital Structure*” beginning on page 79, our Company has not made any capital issues during the three years preceding the date of this Red Herring Prospectus.

## **Performance *vis-à-vis* Objects – Public/ rights issue of the listed Subsidiaries/Promoters of our Company**

None of our Subsidiaries or Promoters are listed on any stock exchange.

## Price Information of past issues handled by the BRLMs

### Axis Capital Limited

1. Price information of past issues (during the current Financial Year and two Financial Years preceding the current Financial Year) handled by Axis Capital Limited.

Sr. No.	Issuer Name	Issue Size (₹ Million)	Issue Price (₹)	Listing Date	Opening Price on Listing Date (₹)	+/- % change in closing price, [+/- % change in closing benchmark] – 30 <sup>th</sup> calendar day from listing	+/- % change in closing price, [+/- % change in closing benchmark] – 90 <sup>th</sup> calendar day from listing	+/- % change in closing price, [+/- % change in closing benchmark] – 180 <sup>th</sup> calendar day from listing
1.	Latent View Analytics Limited <sup>97</sup>	6,000.00	197.00	23-Nov-21	512.20	-	-	-
2.	One Communications Limited	183,000.00	2,150.00	18-Nov-21	1,950.00	-	-	-
3.	S.J.S. Enterprises Limited	8,000.00	542.00	15-Nov-21	542.00	-	-	-
4.	Fino Payments Bank Limited	12,002.93	577.00	12-Nov-21	544.35	-	-	-
5.	Aditya Birla Sun Life AMC Limited	27,682.56	712.00	11-Oct-21	715.00	-11.36%, [+0.55%]	-	-
6.	Ami Organics Limited	5,696.36	610.00	14-Sep-21	910.00	+117.07%, [+4.50%]	-	-
7.	Chemplast Sanmar Limited	38,500.00	541.00	24-Aug-21	550.00	+2.06%, [+5.55%]	+12.68%, [+6.86%]	-
8.	Nuvoco Vistas Corporation Limited	50,000.00	570.00	23-Aug-21	485.00	-5.91%, [+6.46%]	-9.75%, [+7.69%]	-
9.	Cartrade Tech Limited	29,985.13	1,618.00	20-Aug-21	1,599.80	-10.31%, [+6.90%]	-31.01%, [+9.41%]	-
10.	Clean Science And Technology Limited	15,466.22	900.00	19-Jul-21	1,755.00	+66.33%, [+5.47%]	+138.53%, [+16.42%]	-

Source: [www.nseindia.com](http://www.nseindia.com)

<sup>97</sup> Offer Price was ₹ 178.00 per equity share to Eligible Employees

#### Notes:

- Issue Size derived from Prospectus/final post issue reports, as available.
- The CNX NIFTY is considered as the Benchmark Index.
- Price on NSE is considered for all of the above calculations.
- In case 30th/90th/180th day is not a trading day, closing price on NSE of the previous trading day has been considered.
- Since 30 calendar days, 90 calendar days and 180 calendar days, as applicable, from listing date has not elapsed for few of the above issues, data for same is not available.

2. Summary statement of price information of past issues (during the current Financial Year and two Financial Years preceding the current Financial Year) handled by Axis Capital Limited

Financial Year	Total no. of IPOs	Total amount of funds raised (₹ Million)	No. of IPOs trading at discount – 30 <sup>th</sup> calendar day from listing			No. of IPOs trading at premium – 30 <sup>th</sup> calendar day from listing			No. of IPOs trading at discount – 180 <sup>th</sup> calendar day from listing			No. of IPOs trading at premium – 180 <sup>th</sup> calendar day from listing		
			Over 50%	Between 25%-50%	Less than 25%	Over 50%	Between 25%-50%	Less than 25%	Over 50%	Between 25%-50%	Less than 25%	Over 50%	Between 25%-50%	Less than 25%
2021-2022*	16	4,49,586.65	-	-	3	2	4	3	-	-	-	2	-	-
2020-2021	11	93,028.90	-	-	6	2	1	2	-	1	1	4	3	2
2019-2020	5	161,776.03	-	1	2	-	-	2	1	1	-	-	-	3

\* The information is as on the date of the document

The information for each of the financial years is based on issues listed during such financial year.

Note: Since 30 calendar days and 180 calendar days, as applicable, from listing date has not elapsed for few of the above issues, data for same is not available

### JM Financial Limited

1. Price information of past issues (during the current Financial Year and two Financial Years preceding

the current Financial Year) handled by JM Financial Limited.

Sr. No.	Issue name	Issue Size (₹ million)	Issue price (₹)	Listing Date	Opening price on Listing Date (in ₹)	+/- % change in closing price, [+/- % change in closing benchmark] - 30 <sup>th</sup> calendar days from listing	+/- % change in closing price, [+/- % change in closing benchmark] - 90 <sup>th</sup> calendar days from listing	+/- % change in closing price, [+/- % change in closing benchmark] - 180 <sup>th</sup> calendar days from listing
1.	Sapphire Foods India Limited	20,732.53	1,180.00	November 18, 2021	1,350.00	Not Applicable	Not Applicable	Not Applicable
2.	FSN – E-Commerce Ventures Limited <sup>8</sup>	53,497.24	1,125.00	November 10, 2021	2018.00	Not Applicable	Not Applicable	Not Applicable
3.	Aditya Birla Sun Life AMC Limited	27,682.56	712.00	October 11, 2021	715.00	-11.36% [0.55%]	Not Applicable	Not Applicable
4.	Krsnaa Diagnostics Limited <sup>9</sup>	12,133.35	954.00	August 16, 2021	1,005.55	-9.42% [4.93%]	-27.73% [9.30%]	Not Applicable
5.	Rolex Rings Limited	7,310.00	900.00	August 09, 2021	1,250.00	22.28% [6.79%]	31.50% [10.20%]	Not Applicable
6.	Tatva Chintan Pharma Chem Limited	5,000.00	1,083.00	July 29, 2021	2,111.85	92.54% [5.87%]	136.37% [15.78%]	Not Applicable
7.	Clean Science and Technology Limited	15,466.22	900.00	July 19, 2021	1,755	66.33% [5.47%]	138.53% [16.42%]	Not Applicable
8.	India Pesticides Limited	8,000.00	296.00	July 5, 2021	350.00	12.64% [1.87%]	4.26% [10.72%]	Not Applicable
9.	Shyam Metalics and Energy Limited <sup>7</sup>	9,085.50	306.00	June 24, 2021	380.00	40.95% [0.42%]	22.65% [11.22%]	Not Applicable
10.	Sona BLW Precision Forgings Limited	55,500.00	291.00	June 24, 2021	301.00	45.45% [0.42%]	93.40% [11.22%]	Not Applicable

Source: www.nseindia.com for price information and prospectus/basis of allotment for issue details

Notes:

1. Opening price information as disclosed on the website of NSE.
2. Change in closing price over the issue/offer price as disclosed on NSE.
3. Change in closing price over the closing price as on the listing date for benchmark index viz. NIFTY 50.
4. In case of reporting dates falling on a trading holiday, values for the trading day immediately preceding the trading holiday have been considered.
5. 30<sup>th</sup> calendar day has been taken as listing date plus 29 calendar days; 90<sup>th</sup> calendar day has been taken as listing date plus 89 calendar days; 180<sup>th</sup> calendar day has been taken as listing date plus 179 calendar days.
6. Restricted to last 10 issues.
7. A discount of 4.90 % on the Offer Price was offered to the Eligible Employees Bidding in the Employee Reservation Portion (“Employee Discount”) equivalent to ₹ 15 per Equity Share.
8. A discount of Rs. 100 per Equity Share was offered to Eligible Employees bidding in the Employee Reservation Portion.
9. A discount of Rs. 93 per Equity Share was offered to Eligible Employees bidding in the Employee Reservation Portion.
10. Not Applicable – Period not completed

## 2. Summary statement of price information of past issues handled by JM Financial Limited:

Financial Year	Total no. of IPOs	Total funds raised (Millions)	Nos. of IPOs trading at discount on as on 30 <sup>th</sup> calendar days from listing date			Nos. of IPOs trading at premium on as on 30 <sup>th</sup> calendar days from listing date			Nos. of IPOs trading at discount as on 180 <sup>th</sup> calendar days from listing date			Nos. of IPOs trading at premium as on 180 <sup>th</sup> calendar days from listing date		
			Over 50%	Between 25% - 50%	Less than 25%	Over 50%	Between 25% - 50%	Less than 25%	Over 50%	Between 25% - 50%	Less than 25%	Over 50%	Between 25% - 50%	Less than 25%
2021-2022	11	2,39,407.40	-	-	2	2	3	2	-	-	-	1	-	-
2020-2021	8	62,102.09	-	-	3	2	1	2	-	-	-	5	2	1
2019-2020	4	36,400.83*	-	-	1	-	1	2	-	1	1	-	1	1

\*\*Spandana Sphoorty Financial Limited raised Rs. 11,898.49 million as against the issue size of Rs. 12,009.36 million

## Mechanism for Redressal of Investor Grievances

The Registrar Agreement provides for retention of records with the Registrar to the Offer for a minimum period of eight years from the date of listing and commencement of trading of the Equity Shares on the Stock Exchanges, in order to enable the investors to approach the Registrar to the Offer for redressal of their grievances.



Bidder can contact the Compliance Officer, the BRLMs or the Registrar to the Offer in case of any pre-Offer or post-Offer related problems such as non-receipt of letters of Allotment, non-credit of Allotted Equity Shares in the respective beneficiary account, non-receipt of refund orders or non-receipt of funds by electronic mode, etc.

All grievances, other than of Anchor Investors may be addressed to the Registrar to the Offer with a copy to the relevant Designated Intermediary with whom the ASBA Form was submitted, giving full details such as name of the sole or First Bidder, ASBA Form number, Bidder's DP ID, Client ID, PAN, address of Bidder, number of Equity Shares applied for, ASBA Account number in which the amount equivalent to the Bid Amount was blocked or the UPI ID (for Retail Individual Investors who make the payment of Bid Amount through the UPI Mechanism), date of ASBA Form and the name and address of the relevant Designated Intermediary where the Bid was submitted. Further, the Bidder shall enclose the Acknowledgment Slip or the application number from the Designated Intermediary in addition to the documents or information mentioned hereinabove. All grievances relating to Bids submitted through Registered Brokers may be addressed to the Stock Exchanges with a copy to the Registrar to the Offer.

All grievances of the Anchor Investors may be addressed to the Registrar to the Offer, giving full details such as the name of the sole or First Bidder, Bid cum Application Form number, Bidders' DP ID, Client ID, PAN, date of the Bid cum Application Form, address of the Bidder, number of the Equity Shares applied for, Bid Amount paid on submission of the Bid cum Application Form and the name and address of the BRLMs where the Bid cum Application Form was submitted by the Anchor Investor.

The Registrar to the Offer shall obtain the required information from the SCSBs and Sponsor Banks for addressing any clarifications or grievances of ASBA Bidders. Our Company, the BRLMs and the Registrar to the Offer accept no responsibility for errors, omissions, commission or any acts of SCSBs including any defaults in complying with its obligations under applicable SEBI ICDR Regulations. Investors can contact our Company Secretary and Compliance Officer or the Registrar to the Offer in case of any pre-Offer or post-Offer related problems such as non-receipt of letters of Allotment, non-credit of allotted Equity Shares in the respective beneficiary account, non-receipt of refund intimations and non-receipt of funds by electronic mode.

In terms of SEBI circular no. SEBI/HO/CFD/DIL2/CIR/P/2018/22, dated February 15, 2018, any ASBA Bidder whose Bid has not been considered for Allotment, due to failure on the part of any SCSB, shall have the option to seek redressal of the same by the concerned SCSB within three months of the date of listing of the Equity Shares. SCSBs are required to resolve these complaints within 15 days, failing which the concerned SCSB would have to pay interest at the rate of 15% per annum for any delay beyond this period of 15 days.

In case of (i) any delay in unblocking of amounts in the ASBA Accounts (including amounts blocked through the UPI Mechanism) for cancelled/ withdrawn/deleted ASBA Forms, the Bidder shall be compensated at a uniform rate of ₹100 per day or 15% per annum of the Bid Amount, whichever is higher from the date on which the request for cancellation/ withdrawal/ deletion is placed in the Stock Exchanges bidding platform until the date on which the amounts are unblocked (ii) any blocking of multiple amounts for the same ASBA Form (for amounts blocked through the UPI Mechanism), the Bidder shall be compensated at a uniform rate ₹100 per day or 15% per annum of the total cumulative blocked amount except the original application amount, whichever is higher from the date on which such multiple amounts were blocked till the date of actual unblock; (iii) any blocking of amounts more than the Bid Amount, the Bidder shall be compensated at a uniform rate of ₹100 per day or 15% per annum of the difference in amount, whichever is higher from the date on which such excess amounts were blocked till the date of actual unblock; (iv) any delay in unblocking of non-allotted/ partially allotted Bids, exceeding four Working Days from the Bid/Offer Closing Date, the Bidder shall be compensated at a uniform rate of ₹100 per day or 15% per annum of the Bid Amount, whichever is higher for the entire duration of delay exceeding four Working Days from the Bid/ Offer Closing Date by the SCSB responsible for causing such delay in unblocking. The post Offer BRLMs shall be liable for compensating the Bidder at a uniform rate of ₹100 per day or 15% per annum of the Bid Amount, whichever is higher from the date of receipt of the Investor grievance until the date on which the blocked amounts are unblocked.

Our Company, the BRLMs and the Registrar to the Offer accept no responsibility for errors, omissions, commission of any acts of the Designated Intermediaries, including any defaults in complying with its obligations under the SEBI ICDR Regulations.

#### **Disposal of Investor Grievances by our Company**

Our Company has not received any investor grievances during the three years preceding the date of the Draft Red Herring Prospectus or this Red Herring Prospectus and as on date, there are no investor complaints pending.

We estimate that the average time required by our Company and/ or the Registrar to the Offer for the redressal of routine investor grievances shall be seven Working Days from the date of receipt of the complaint. In case of non-routine complaints and complaints where external agencies are involved, our Company will seek to redress these complaints as expeditiously as possible.

Our Company has appointed Sudipta Bhowal as the Compliance Officer and he may be contacted in case of any pre-Offer or post-Offer related problems, at the address set forth hereunder.

**Sudipta Bhowal**

147, Block-G

New Alipore

Kolkata 700 053

West Bengal, India

Tel: +91 33 3001 9000

**E-mail:** compliance.officer@tegaindustries.com

The Selling Shareholders have authorised the Compliance Officer of our Company and the Registrar to the Offer to redress any complaints received from Bidders in respect of their respective portion of the Offered Shares.

Our Company has obtained authentication on the SCORES and shall comply with the SEBI circular (CIR/OIAE/1/2013) dated April 17, 2013 and SEBI circular (CIR/OIAE/1/2014) dated December 18, 2014 in relation to redressal of investor grievances through SCORES.

Further, our Board has constituted a Stakeholders' Relationship Committee, which is responsible for redressal of grievances of the security holders of our Company. For more information, see "**Our Management**" beginning on page 180.

**Capital Issues in the Preceding Three Years**

Except as disclosed in "**Capital Structure - History of Equity Share capital of our Company**" on page 79, our Company has not made any capital issues during the three years immediately preceding the date of this Red Herring Prospectus. None of our Subsidiaries have made any capital issues during the three years preceding the date of this Red Herring Prospectus.

**Performance vis-à-vis Objects**

Our Company has not undertaken any public issues, including any rights issues to the public in the 10 years immediately preceding the date of this Red Herring Prospectus.

**Performance vis- à-vis Objects: Last Issue of Subsidiaries**

None of our Subsidiaries have made any public issues, including rights issues to the public in the 10 years immediately preceding the date of this Red Herring Prospectus.

**Commission /brokerage on previous issues in the last five years**

Nil

**Stock Market Data of the Equity Shares**

This being the initial public offering of the Equity Shares of our Company, the Equity Shares are not listed on any stock exchange as on the date of this Red Herring Prospectus, and accordingly, no stock market data is available for the Equity Shares.

## SECTION VII – OFFER RELATED INFORMATION

### TERMS OF THE OFFER

The Equity Shares offered and Allotted in the Offer will be subject to the provisions of the Companies Act, the SEBI ICDR Regulations, the SCRR, the Memorandum of Association, the Articles of Association, the SEBI Listing Regulations, the terms of this Red Herring Prospectus, the Red Herring Prospectus and the Prospectus, the Bid cum Application Form, the Revision Form, the abridged prospectus and other terms and conditions as may be incorporated in the CAN (for Anchor Investors), Allotment Advice and other documents and certificates that may be executed in respect of the Offer. The Equity Shares shall also be subject to all applicable laws, guidelines, rules, notifications and regulations relating to offer for sale and listing and trading of securities, issued from time to time, by the SEBI, Government of India, Stock Exchange, the RoC, the RBI and/or other authorities, as in force on the date of the Offer and to the extent applicable or such other conditions as maybe prescribed by SEBI, RBI and/or any regulatory authority while granting approval for the Offer.

#### Ranking of Equity Shares

The Equity Shares being offered and transferred pursuant to the Offer shall be subject to the provisions of the Companies Act, SEBI Listing Regulations, SEBI ICDR Regulations, SCRA read with SCRR, the Memorandum of Association and the Articles of Association and will rank *pari passu* in all respects with the existing Equity Shares of our Company, including in respect of rights to receive dividends and other corporate benefits, if any, declared by our Company after the date of transfer in accordance with applicable law. For more information, see “*Main Provisions of Articles of Association*” beginning on page 398.

#### Mode of Payment of Dividend

Our Company will pay dividend, if declared, to our Shareholders, as per the provisions of the Companies Act 2013, the SEBI Listing Regulations, our Memorandum of Association and the Articles of Association, and any guidelines or directives that may be issued by the Government of India in this respect. Any dividends declared, after the date of Allotment (including pursuant to the transfer of Equity Shares in the Offer for Sale) in this Offer, will be received by the Allottees. For more information, see “*Dividend Policy*” and “*Main Provisions of Articles of Association*” on pages 206 and 398, respectively.

#### Face Value and Price Band

The face value of each Equity Share is ₹10 and the Offer Price at the lower end of the Price Band is ₹[•] per Equity Share and at the higher end of the Price Band is ₹[•] per Equity Share. The Anchor Investor Offer Price is ₹[•] per Equity Share. At any given point in time there will be only one denomination for the Equity Shares.

The Price Band, the minimum Bid Lot, will be decided by our Company and the Selling Shareholders in consultation with the BRLMs, and published by our Company in all editions of Financial Express (a widely circulated English national daily newspaper), all editions of Jansatta (a widely circulated Hindi national daily newspaper) and all editions of Arthik Lipi (a widely circulated Bengali daily, Bengali being the regional language of West Bengal, where our Registered Office is located) at least two Working Days prior to the Bid/ Offer Opening Date, in, and shall be made available to the Stock Exchanges for the purpose of uploading the same on their websites. The Price Band, along with the relevant financial ratios calculated at the Floor Price and at the Cap Price shall be pre-filled in the Bid-cum-Application Forms available at the respective websites of the Stock Exchanges.

#### Compliance with disclosure and accounting norms

Our Company shall comply with all disclosure and accounting norms as specified by SEBI from time to time.

#### Rights of the Equity Shareholder

Subject to applicable law and our Articles of Association, the Equity Shareholders will have the following rights:

- Right to receive dividend, if declared;
- Right to attend general meetings and exercise voting powers, unless prohibited by law;
- Right to vote on a poll either in person or by proxy and e-voting;

- Right to receive offers for rights shares and be allotted bonus shares, if announced;
- Right to receive any surplus on liquidation subject to any statutory and preferential claims being satisfied;
- Right of free transferability of their Equity Shares, subject to applicable foreign exchange regulations and other applicable law; and
- Such other rights as may be available to a shareholder of a listed public company under the Companies Act, the terms of the SEBI Listing Regulations and our Memorandum of Association and Articles of Association.

For a detailed description of the main provisions of our Articles of Association relating to voting rights, dividend, forfeiture, lien, transfer, transmission, consolidation and splitting, see “*Main Provisions of the Articles of Association*” beginning on page 398.

#### **Option to receive Equity Shares in Dematerialised Form**

Pursuant to Section 29 of the Companies Act, 2013 the Equity Shares shall be allotted only in dematerialised form. As per the SEBI ICDR Regulations, the trading of the Equity Shares shall only be in dematerialised form.

In this context, two agreements have been signed amongst our Company, the respective Depositories and the Registrar to the Offer:

- Tripartite Agreement dated August 7, 2021 among NSDL, our Company and the Registrar to the Offer.
- Tripartite Agreement dated August 4, 2021 among CDSL, our Company and Registrar to the Offer.

#### **Market Lot and Trading Lot**

Since trading of our Equity Shares is in dematerialised form, the tradable lot is one Equity Share. Allotment in the Offer will be only in electronic form in multiples of one Equity Share, subject to a minimum Allotment of [•] Equity Shares. For the method of Basis of Allotment, see “*Offer Procedure*” beginning on page 380.

#### **Jurisdiction**

Exclusive jurisdiction for the purpose of the Offer is with the competent courts/ authorities in Kolkata, West Bengal.

#### **Joint Holders**

Subject to provisions contained in our Articles, where two or more persons are registered as the holders of any Equity Shares, they will be deemed to hold such Equity Shares as joint-tenants with benefits of survivorship.

#### **Nomination Facility**

In accordance with Section 72 of the Companies Act read with Companies (Share Capital and Debentures) Rules, 2014, as amended, the sole Bidder, or the first Bidder along with other joint Bidders, may nominate any one person in whom, in the event of the death of sole Bidder or in case of joint Bidders, death of all the Bidders, as the case may be, the Equity Shares Allotted, if any, shall vest. A person, being a nominee, entitled to the Equity Shares by reason of the death of the original holder(s), shall be entitled to the same advantages to which he or she would be entitled if he or she were the registered holder of the Equity Share(s). Where the nominee is a minor, the holder(s) may make a nomination to appoint, in the prescribed manner, any person to become entitled to Equity Share(s) in the event of his or her death during the minority. A nomination shall stand rescinded upon a sale, transfer or alienation of Equity Share(s) by the person nominating. A buyer will be entitled to make a fresh nomination in the manner prescribed. Fresh nomination can be made only on the prescribed form available on request at our Registered Office or to the registrar and transfer agents of our Company.

Further, any person who becomes a nominee by virtue of Section 72 of the Companies Act 2013, as amended, will, on the production of such evidence as may be required by our Board, elect either:

- to register himself or herself as holder of Equity Shares; or

- to make such transfer of the Equity Shares, as the deceased holder could have made.

Further, our Board may at any time give notice requiring any nominee to choose either to be registered himself or herself or to transfer the Equity Shares, and if the notice is not complied with within a period of 90 days, our Board may thereafter withhold payment of all dividend, interests, bonuses or other monies payable in respect of the Equity Shares, until the requirements of the notice have been complied with.

Since the Allotment of Equity Shares in the Offer will be made only in dematerialised form, there is no need to make a separate nomination with our Company. Nominations registered with the respective Depository Participant of the Bidder will prevail. If Bidders want to change their nomination, they are advised to inform their respective Depository Participants.

#### **Bid/ Offer Period**

<b>BID/ OFFER OPENS ON*</b>	December 1, 2021
<b>BID/ OFFER CLOSES ON#</b>	December 3, 2021

\* *Our Company and the Selling Shareholders may, in consultation with the BRLMs, consider participation by Anchor Investors. The Anchor Investor Bid/ Offer Period shall be one Working Day prior to the Bid/ Offer Opening Date*

# *UPI mandate end time and date shall be at 12.00pm on Monday, December 6, 2021.*

An indicative timetable in respect of the Offer is set out below:

<b>BID/ OFFER CLOSING DATE</b>	December 3, 2021
<b>FINALISATION OF BASIS OF ALLOTMENT WITH THE DESIGNATED STOCK EXCHANGE</b>	on or about December 8, 2021
<b>INITIATION OF REFUNDS FOR ANCHOR INVESTORS/UNBLOCKING OF FUNDS FROM ASBA ACCOUNT<sup>(1)</sup></b>	on or about December 9, 2021
<b>CREDIT OF EQUITY SHARES TO DEPOSITORY ACCOUNTS</b>	on or about December 10, 2021
<b>COMMENCEMENT OF TRADING OF THE EQUITY SHARES ON THE STOCK EXCHANGE</b>	on or about December 13, 2021

(1) *In case of any delay in unblocking of amounts in the ASBA Accounts (including amounts blocked through the UPI Mechanism) exceeding four Working Days from the Bid/Offer Closing Date, the Bidder shall be compensated by the intermediary responsible for causing such delay in unblocking in accordance with applicable law. Further, investors shall be entitled to compensation in the manner specified in the SEBI circular no. SEBI/HO/CFD/DIL1/CIR/P/2021/47 dated March 31, 2021, SEBI circular no. SEBI/HO/CFD/DIL2/CIR/P/2021/2480/1/M dated March 16, 2021, as amended and SEBI circular no. SEBI/HO/CFD/DIL2/P/CIR/2021/570 dated June 2, 2021 in case of delays in resolving investor grievances in relation to blocking/unblocking of funds.*

In case of (i) any delay in unblocking of amounts in the ASBA Accounts (including amounts blocked through the UPI Mechanism) for cancelled/ withdrawn/deleted ASBA Forms, the Bidder shall be compensated at a uniform rate of ₹100 per day or 15% per annum of the Bid Amount, whichever is higher from the date on which the request for cancellation/ withdrawal/ deletion is placed in the Stock Exchanges bidding platform until the date on which the amounts are unblocked; (ii) any blocking of multiple amounts for the same ASBA Form (for amounts blocked through the UPI Mechanism), the Bidder shall be compensated by the SCSB at a uniform rate ₹100 per day or 15% per annum of the total cumulative blocked amount except the original application amount, whichever is higher from the date on which such multiple amounts were blocked till the date of actual unblock; (iii) any blocking of amounts more than the Bid Amount, the Bidder shall be compensated at a uniform rate of ₹100 per day or 15% per annum of the difference in amount, whichever is higher from the date on which such excess amounts were blocked till the date of actual unblock; (iv) any delay in unblocking of non-allotted/ partially allotted Bids, exceeding four Working Days from the Bid/Offer Closing Date, the Bidder shall be compensated at a uniform rate of ₹100 per day or 15% per annum of the Bid Amount, whichever is higher for the entire duration of delay exceeding four Working Days from the Bid/ Offer Closing Date till the date of the actual unblock. The SCSBs shall compensate the Bidder, immediately on the date of receipt of complaint from the Bidder. From the date of receipt of complaint from the Bidder, in addition to the compensation to be paid as stated above, the post-Offer BRLMs shall be liable for compensating the Bidder at a uniform rate of ₹100 per day or 15% per annum of the Bid Amount, whichever is higher from the date of on which grievance is received by the BRLMs or Registrar until the date on which the blocked amounts are unblocked.

**The above timetable, other than the Bid/ Offer Closing Date, is indicative and does not constitute any obligation on our Company or the Selling Shareholders or the BRLMs.**

Whilst our Company shall ensure that all steps for the completion of the necessary formalities for the listing and the commencement of trading of the Equity Shares on the Stock Exchanges are taken within six Working Days of the Bid/ Offer Closing Date or such period as may be prescribed, the timetable may be extended due to various factors, such as extension of the Bid/ Offer Period by our Company and the Selling Shareholders, revision of the Price Band or any delay in receiving the final listing and trading approval from the Stock Exchanges. The commencement of trading of the Equity Shares will be entirely at the discretion of the Stock Exchanges and in accordance with the applicable laws. Each of the Selling Shareholders, severally and not jointly, confirm that they shall extend reasonable co-operation required by our Company and the BRLMs for the completion of the necessary formalities for listing and commencement of trading of the Equity Shares at the Stock Exchanges within six Working Days from the Bid/ Offer Closing Date or such other period as may be prescribed.

SEBI is in the process of streamlining and reducing the post issue timeline for IPOs. Any circulars or notifications from SEBI after the date of this Red Herring Prospectus may result in changes to the above mentioned timelines. Further, the offer procedure is subject to change basis any revised SEBI circulars to this effect.

**Submission of Bids (other than Bids from Anchor Investors):**

<b>Bid/ Offer Period (except the Bid/ Offer Closing Date)</b>	
Submission and Revision in Bids	Only between 10.00 a.m. and 5.00 p.m. Indian Standard Time (“IST”)
<b>Bid/ Offer Closing Date*</b>	
Submission and Revision in Bids	Only between 10.00 a.m. and 3.00 p.m. IST

*\*UPI mandate end time and date shall be at 12.00pm on Monday, December 6, 2021.*

**On the Bid/ Offer Closing Date, the Bids shall be uploaded until:**

- (i) 4.00 p.m. IST in case of Bids by QIBs and Non-Institutional Bidders, and
- (ii) until 5.00 p.m. IST or such extended time as permitted by the Stock Exchanges, in case of Bids by Retail Individual Investors.

On Bid/ Offer Closing Date, extension of time will be granted by Stock Exchanges only for uploading Bids received by Retail Individual Investors after taking into account the total number of Bids received and as reported by the BRLMs to the Stock Exchanges.

The Registrar to the Offer shall submit the details of cancelled/withdrawn/deleted applications to the SCSB’s on daily basis within 60 minutes of the Bid closure time from the Bid/ Offer Opening Date till the Bid/Offer Closing Date by obtaining the same from the Stock Exchanges. The SCSB’s shall unblock such applications by the closing hours of the Working Day.

**It is clarified that Bids not uploaded on the electronic bidding system or in respect of which the full Bid Amount is not blocked in the relevant ASBA Account, would be rejected.**

Due to limitation of time available for uploading the Bids on the Bid/ Offer Closing Date, Bidders are advised to submit their Bids one day prior to the Bid/ Offer Closing Date. Any time mentioned in this Red Herring Prospectus is IST. Bidders are cautioned that, in the event a large number of Bids are received on the Bid/ Offer Closing Date, some Bids may not get uploaded due to lack of sufficient time. Such Bids that cannot be uploaded will not be considered for allocation under the Offer. Bids will be accepted only during Working Days.

Our Company and the Selling Shareholders in consultation with the BRLMs, reserve the right to revise the Price Band during the Bid/ Offer Period in accordance with the SEBI ICDR Regulations. The revision in the Price Band shall not exceed 20% on either side, i.e. the Floor Price may move up or down to the extent of 20% of the Floor Price and the Cap Price will be revised accordingly, but the Floor Price shall not be less than the face value of the Equity Shares. In all circumstances, the Cap price shall be less than or equal to 120% of the Floor Price.

**In case of any revision to the Price Band, the Bid/ Offer Period will be extended by at least three additional Working Days following such revision of the Price Band, subject to the Bid/ Offer Period not exceeding 10 Working Days. In cases of force majeure, banking strike or similar circumstances, our Company may, for reasons to be recorded in writing, extend the Bid/ Offer Period for a minimum of three Working Days, subject to the Bid/ Offer Period not exceeding 10 Working Days. Any revision in the Price Band and the revised Bid/ Offer Period, if applicable, will be widely disseminated by notification to the Stock Exchanges,**

**by issuing a public notice, and also by indicating the change on the respective websites of the BRLMs and at the terminals of the Syndicate Members and by intimation to the Designated Intermediaries and the Sponsor Bank, as applicable.**

#### **Minimum Subscription**

The requirement of minimum subscription is not applicable to the Offer in accordance with the SEBI ICDR Regulations. However, if our Company does not make the minimum Allotment as specified under terms of the Rule 19(2)(b) of the SCRR, including devolvement of Underwriters, if any, the Selling Shareholders, to the extent applicable, and our Company shall forthwith refund the entire subscription amount received. If there is a delay beyond four days, interest at the rate of 15% per annum shall be paid by our Company and each of our Directors, in accordance SEBI circular bearing no. SEBI/HO/CFD/DIL2/CIR/P/2021/2480/1/M dated March 16, 2021, including the SEBI circular bearing no. SEBI/HO/CFD/DIL1/CIR/P/2021/47 dated March 31, 2021.

Further, in terms of Regulation 49(1) of the SEBI ICDR Regulations, our Company shall ensure that the number of Bidders to whom the Equity Shares will be Allotted will be not less than 1,000.

It is clarified that, subject to applicable laws, none of the Selling Shareholders shall be liable to pay any amounts as interest for any delay, unless such default or delay is solely and directly attributable to an act or omission of such Selling Shareholders.

#### **Arrangements for Disposal of Odd Lots**

Since the Equity Shares will be treated in dematerialised form only, and the market lot for the Equity Shares will be one Equity Share, there are no arrangements for disposal of odd lots.

#### **Restrictions, if any on Transfer and Transmission of Equity Shares**

Except for lock-in of pre-Offer equity shareholding, minimum Promoters' contribution and Anchor Investor lock-in in the Offer, as detailed in "*Capital Structure*" on page 79 and as provided in our Articles as detailed in "*Main Provisions of the Articles of Association*" on page 398, there are no restrictions on transfers and transmission of shares/debentures and on their consolidation/ splitting.

## OFFER STRUCTURE

The Offer is up to 13,669,478 Equity Shares of face value of ₹10 each, for cash at a price of ₹[•] per equity share of up through an Offer for Sale by the Selling Shareholders.

In terms of Rule 19(2)(b) of the SCRR, the Offer is being made through the Book Building Process, in compliance with Regulation 31 of the SEBI ICDR Regulations

Particulars	QIBs <sup>(1)</sup>	Non-Institutional Bidders	Retail Individual Investors
Number of Equity Shares available for Allotment or allocation <sup>*(2)</sup>	Not more than 6,834,738 Equity Shares aggregating up to ₹ [•] million	Not less than 2,050,422 Equity Shares aggregating up to ₹ [•] million	Not less than 4,784,318 Equity Shares aggregating up to ₹ [•] million
Percentage of Offer Size available for Allotment or allocation	Not more than 50% of the Offer being available for allocation to QIB Bidders. However, up to 5% of the QIB Portion will be available for allocation proportionately to Mutual Funds only. Mutual Funds participating in the Mutual Fund Portion will also be eligible for allocation in the remaining QIB Portion (excluding the Anchor Investor Portion). The unsubscribed portion in the Mutual Fund Portion will be available for allocation to other QIBs	Not less than 15% of the Offer or the Offer less allocation to QIB Bidders and RII	Not less than 35% of the Offer or the Offer less allocation to QIB Bidders and Non-Institutional Bidders
Basis of Allotment if respective category is oversubscribed*	Proportionate as follows (excluding the Anchor Investor Portion): a) up to 136,695 Equity Shares shall be available for allocation on a proportionate basis to Mutual Funds only; and b) up to 2,597,201 Equity Shares shall be available for allocation on a proportionate basis to all QIBs, including Mutual Funds receiving allocation as per (a) above. c) Not more than 4,100,842 Equity Shares may be allocated on a discretionary basis to Anchor Investors	Proportionate	The allotment to each RII shall not be less than the minimum Bid Lot, subject to availability of Equity Shares in the Retail Portion and the remaining available Equity Shares if any, shall be Allotted on a proportionate basis. For further details, see “ <i>Offer Procedure</i> ” beginning on page [•].
Mode of Bid	Through ASBA Process only (except in case of Anchor Investors)		
Minimum Bid	Such number of Equity Shares in multiples of [•] Equity Shares such that the Bid Amount exceeds ₹200,000.	Such number of [•] Equity Shares in multiples of [•] Equity Shares such that the Bid Amount exceeds ₹200,000.00.	[•] Equity Shares and in multiples of [•] Equity Shares thereafter



Particulars	QIBs <sup>(1)</sup>	Non-Institutional Bidders	Retail Individual Investors
Maximum Bid	Such number of Equity Shares in multiples of [•] Equity Shares not exceeding the size of the Offer, subject to applicable limits	Such number of Equity Shares in multiples of [•] Equity Shares not exceeding the size of the Offer, (excluding the QIB Portion) subject to limits applicable to the Bidder	Such number of Equity Shares in multiples of [•] Equity Shares so that the Bid Amount does not exceed ₹200,000
Mode of Allotment	Compulsorily in dematerialised form		
Bid Lot	[•] Equity Shares and in multiples of [•] Equity Shares thereafter		
Allotment Lot	[•] Equity Shares and in multiples of one Equity Share thereafter		
Trading Lot	One Equity Share		
Who can apply <sup>(3)</sup>	Public financial institutions of the Companies Act, scheduled commercial banks, multilateral and bilateral development financial institutions, Mutual Funds, FPIs other than individuals, corporate bodies and family offices, VCFs, AIFs, FVCIs, state industrial development corporation, insurance company registered with IRDAI, provident funds with minimum corpus of ₹250 million, pension funds with minimum corpus of ₹250 million, National Investment Fund set up by the GoI, insurance funds set up and managed by army, navy or air force of the Union of India, insurance funds set up and managed by the Department of Posts, India and Systemically Important NBFCs	Resident individuals, NRIs, HUFs (in the name of the karta), companies, corporate bodies, scientific institutions, societies, trusts, family offices and FPIs who are individuals, corporate bodies and family offices which are re-categorised as company registered with SEBI.	Resident individuals, NRIs and HUFs (in the name of the karta)
Terms of Payment	<p><b>In case of Anchor Investors:</b> Full Bid Amount shall be payable by the Anchor Investors at the time of submission of their Bids<sup>(4)</sup></p> <p><b>In case of all other Bidders:</b> Full Bid Amount shall be blocked by the SCSBs in the bank account of the ASBA Bidder (other than Anchor Investors), or by the Sponsor Bank through the UPI Mechanism, that is specified in the ASBA Form at the time of submission of the ASBA Form</p>		

\* Assuming full subscription in the Offer.

- (1) Our Company and the Selling Shareholders may, in consultation with the BRLMs, allocate up to 60% of the QIB Category to Anchor Investors at the Anchor Investor Offer Price, on a discretionary basis, subject to there being (i) a maximum of two Anchor Investors, where allocation in the Anchor Investor Portion is up to ₹100.00 million, (ii) minimum of two and maximum of 15 Anchor Investors, where the allocation under the Anchor Investor Portion is more than ₹100.00 million but up to ₹2,500.00 million under the Anchor Investor Portion, subject to a minimum Allotment of ₹50.00 million per Anchor Investor, and (iii) in case of allocation above ₹2,500.00 million under the Anchor Investor Portion, a minimum of five such investors and a maximum of 15 Anchor Investors for allocation up to ₹2,500.00 million, and an additional 10 Anchor Investors for every additional ₹2,500.00 million or part thereof will be permitted, subject to minimum allotment of ₹50.00 million per Anchor Investor. An Anchor Investor will make a minimum Bid of such number of Equity Shares, that the Bid Amount is at least ₹100.00 million. One-third of the Anchor Investor Portion will be reserved for domestic Mutual Funds, subject to valid Bids being received at or above the price at which allocation is made to Anchor Investors, which price shall be determined by the Company and the Selling Shareholders in consultation with the BRLMs.
- (2) Subject to valid Bids being received at or above the Offer Price. This Offer is being made in accordance with Rule 19(2)(b) of the SCRR and Regulation 6(1) of the SEBI ICDR Regulations.
- (3) In case of joint Bids, the Bid cum Application Form should contain only the name of the first Bidder whose name should also appear as the first holder of the beneficiary account held in joint names. The signature of only such first Bidder would be required in the Bid cum Application Form and such first Bidder would be deemed to have signed on behalf of the joint holders.
- (4) Bidders will be required to confirm and will be deemed to have represented to our Company, the Selling Shareholders, the Underwriters, their respective directors, officers, agents, affiliates and representatives that they are eligible under applicable law, rules, regulations,

- guidelines and approvals to acquire the Equity Shares.*
- (5) *Full Bid Amount shall be payable by the Anchor Investors at the time of submission of the Anchor Investor Application Forms provided that any difference between the Anchor Investor Allocation Price and the Anchor Investor Offer Price shall be payable by the Anchor Investor pay-in date as indicated in the CAN.*

### **Withdrawal of the Offer**

Our Company and the Selling Shareholders, in consultation with the BRLMs, reserves the right not to proceed with the Offer after the Bid/ Offer Opening Date but before the Allotment. In such an event, our Company would issue a public notice in the newspapers in which the pre-Offer advertisements were published, within two days of the Bid/ Offer Closing Date or such other time as may be prescribed by SEBI, providing reasons for not proceeding with the Offer. The BRLMs, through the Registrar to the Offer, shall notify the SCSBs and the Sponsor Bank, in case of RIIs using the UPI Mechanism, to unblock the bank accounts of the ASBA Bidders and the BRLMs shall notify the Escrow Collection Bank to release the Bid Amounts to the Anchor Investors, within one Working Day from the date of receipt of such notification. Our Company shall also inform the same to the Stock Exchanges on which Equity Shares are proposed to be listed.

Notwithstanding the foregoing, the Offer is also subject to obtaining the final listing and trading approvals of the Stock Exchanges, which our Company shall apply for after Allotment and within six Working Days of the Bid/ Offer Closing Date or such other time period as prescribed under Applicable Law. If our Company withdraws the Offer after the Bid/ Offer Closing Date and thereafter determines that it will proceed with an issue or offer for sale of the Equity Shares, our Company shall file a fresh draft red herring prospectus with SEBI and the Stock Exchanges.

## OFFER PROCEDURE

All Bidders should read the General Information Document for Investing in Public Issues prepared and issued in accordance with the circular no. SEBI/HO/CFD/DIL1/CIR/P/2020/37 dated March 17, 2020 and the UPI Circulars (the “**General Information Document**”) which highlights the key rules, processes and procedures applicable to public issues in general in accordance with the provisions of the Companies Act 2013, the SCRA, the SCRR and the SEBI ICDR Regulations which is part of the abridged prospectus accompanying the Bid cum Application Form. The General Information Document is available on the websites of the Stock Exchanges and the BRLMs. Please refer to the relevant provisions of the General Information Document which are applicable to the Offer.

Additionally, all Bidders may refer to the General Information Document for information in relation to (i) category of investors eligible to participate in the Offer; (ii) maximum and minimum Bid size; (iii) price discovery and allocation; (iv) payment instructions for ASBA Bidders; (v) issuance of Confirmation of Allocation Note (“**CAN**”) and Allotment in the Offer; (vi) general instructions (limited to instructions for completing the Bid cum Application Form); (vii) designated date; (viii) disposal of applications; (ix) submission of Bid cum Application Form; (x) other instructions (limited to joint bids in cases of individual, multiple bids and instances when an application would be rejected on technical grounds); (xi) applicable provisions of Companies Act, 2013 relating to punishment for fictitious applications; (xii) mode of making refunds; and (xiii) interest in case of delay in Allotment or refund.

SEBI through its circular (SEBI/HO/CFD/DIL2/CIR/P/2018/138) dated November 1, 2018 as amended from time to time, including pursuant to circular (SEBI/HO/CFD/DIL2/CIR/P/2019/50) dated April 3, 2019 has proposed to introduce an alternate payment mechanism using Unified Payments Interface (“**UPI**”) and consequent reduction in timelines for listing in a phased manner. UPI has been introduced in a phased manner as a payment mechanism with the ASBA for applications by Retail Individual Investors through intermediaries from January 1, 2019. The UPI Mechanism for Retail Individual Investors applying through Designated Intermediaries, in phase I, was effective along with the prior process and existing timeline of T+6 days (“**UPI Phase I**”), until June 30, 2019. Subsequently, for applications by Retail Individual Investors through Designated Intermediaries, the process of physical movement of forms from Designated Intermediaries to SCSBs for blocking of funds has been discontinued and only the UPI Mechanism with existing timeline of T+6 days is applicable for a period of three months or launch of five main board public issues, whichever is later (“**UPI Phase II**”), with effect from July 1, 2019, by SEBI circular (SEBI/HO/CFD/DIL2/CIR/P/2019/76) dated June 28, 2019, read with circular (SEBI/HO/CFD/DIL2/CIR/P/2019/85) dated July 26, 2019. Further, as per the SEBI circular (SEBI/HO/CFD/DCR2/CIR/P/2019/133) dated November 8, 2019, the UPI Phase II had been extended until March 31, 2020. However, due to the outbreak of COVID-19 pandemic, UPI Phase II has been further extended by SEBI until further notice, by its circular (SEBI/HO/CFD/DIL2/CIR/P/2020/50) dated March 30, 2020. Thereafter, the final reduced timeline of T+3 days may be made effective using the UPI Mechanism for applications by Retail Individual Investors (“**UPI Phase III**”), as may be prescribed by SEBI. Accordingly, the Offer has been considered to be made under UPI Phase II, till any further notice issued by SEBI. If the Offer is made under UPI Phase III, the same will be advertised in all edition of Financial Express (a widely circulated English national daily newspaper), all edition of Jansatta (a widely circulated Hindi national daily newspaper) and all edition of Arthik Lipi (a widely circulated Bengali daily, Bengali being the regional language of West Bengal, where our Registered Office is located) on or prior to the Bid / Offer Opening Date and such advertisement shall also be made available to the Stock Exchanges for the purpose of uploading on their websites. Further, SEBI vide its circular (SEBI/HO/CFD/DIL2/CIR/P/2021/2480/1/M) dated March 16, 2021 has introduced certain additional measures for streamlining the process of initial public offers and redressing investor grievances. This circular shall come into force for initial public offers opening on or after May 1, 2021 and the provisions of this circular are deemed to form part of this Red Herring Prospectus. Additionally, SEBI vide its circular no. SEBI/HO/CFD/DIL2/P/CIR/2021/570 dated June 2, 2021 has provided certain implementation timelines for the provisions of the circular no. SEBI/HO/CFD/DIL2/CIR/P/2021/2480/1/M dated March 16, 2021.

Our Company, the respective Selling Shareholders and the BRLMs do not accept any responsibility for the completeness and accuracy of the information stated in this section and are not liable for any amendment, modification or change in the applicable law which may occur after the date of this Red Herring Prospectus and the Red Herring Prospects. Bidders are advised to make their independent investigations and ensure that their Bids are submitted in accordance with applicable laws and do not exceed the investment limits or maximum number of Equity Shares that can be held by them under applicable law or as specified in this Red Herring Prospectus and this Prospectus.

*Further, our Company, the Selling Shareholders and the members of the Syndicate do not accept any responsibility for any adverse occurrences consequent to the implementation of the UPI Mechanism for application in the Offer.*

### **Book Building Procedure**

The Offer is being made through the Book Building Process in accordance with Regulation 6(1) of the SEBI ICDR Regulations wherein not more than 50% of the Offer shall be allocated on a proportionate basis to QIBs, provided that our Company and the Selling Shareholders may, in consultation with the BRLMs, allocate up to 60% of the QIB Portion to Anchor Investors on a discretionary basis in accordance with the SEBI ICDR Regulations, of which one-third shall be reserved for domestic Mutual Funds, subject to valid Bids being received from domestic Mutual Funds at or above the Anchor Investor Allocation Price. In the event of under-subscription, or non-allocation in the Anchor Investor Portion, the balance Equity Shares shall be added to the QIB Portion. Further, 5% of the net QIB Portion (excluding the Anchor Investor Portion) shall be available for allocation on a proportionate basis only to Mutual Funds, and the remainder of the QIB Portion shall be available for allocation on a proportionate basis to all QIBs (other than Anchor Investors), including Mutual Funds, subject to valid Bids being received at or above the Offer Price. Further, not less than 15% of the Offer shall be available for allocation on a proportionate basis to Non-Institutional Investors and not less than 35% of the Offer shall be available for allocation to Retail Individual Investors in accordance with the SEBI ICDR Regulations, subject to valid Bids being received at or above the Offer Price.

Subject to valid Bids being received at or above the Offer Price, undersubscription, if any, in any category, except the QIB Portion, would be allowed to be met with spill-over from any other category or a combination of categories at the discretion of our Company and the Selling Shareholders in consultation with the BRLMs, and the Designated Stock Exchange. However, under-subscription, if any, in the QIB Portion will not be allowed to be met with spill-over from other categories or a combination of categories. In accordance with Rule 19(2)(b) of the SCRR, the Offer will constitute at least 10% of the post Offer paid-up Equity Share capital of our Company. Bidders will not have the option of being Allotted Equity Shares in physical form. However, they may get the Equity Shares rematerialised subsequent to Allotment of the Equity Shares in the IPO.

The Equity Shares, on Allotment, shall be traded only in the dematerialised segment of the Stock Exchanges.

Investors should note that the Equity Shares will be Allotted to all successful Bidders only in dematerialised form. The Bid cum Application Forms which do not have the details of the Bidders' depository account, including DP ID, Client ID, PAN and UPI ID, as applicable, shall be treated as incomplete and will be rejected. Bidders will not have the option of being Allotted Equity Shares in physical form. However, they may get the Equity Shares rematerialized subsequent to Allotment of the Equity Shares in the Offer, subject to applicable laws.

### **Phased implementation of Unified Payments Interface**

SEBI has issued the UPI Circulars in relation to streamlining the process of public issue of *inter alia* equity shares. Pursuant to the UPI Circulars, the UPI Mechanism has been introduced in a phased manner as a payment mechanism (in addition to mechanism of blocking funds in the account maintained with SCSBs under ASBA) for applications by RIIs through Designated Intermediaries with the objective to reduce the time duration from public issue closure to listing from six Working Days up to three Working Days. Considering the time required for making necessary changes to the systems and to ensure complete and smooth transition to the UPI payment mechanism, the UPI Circulars have introduced the UPI Mechanism in three phases in the following manner:

**Phase I:** This phase was applicable from January 1, 2019 until March 31, 2019 or floating of five main board public issues, whichever was later. Subsequently, the timeline for implementation of Phase I was extended till June 30, 2019. Under this phase, an RII had the option to submit the ASBA Form with any of the Designated Intermediary and use his/her UPI ID for the purpose of blocking of funds. The time duration from public issue closure to listing continued to be six Working Days.

**Phase II:** This phase has become applicable from July 1, 2019 and the continuation of this phase has been extended until March 31, 2020. Under this phase, submission of the ASBA Form by RIIs through Designated Intermediaries (other than SCSBs) to SCSBs for blocking of funds has been discontinued and is replaced by the UPI Mechanism. However, the time duration from public issue closure to listing continues to be six Working Days during this phase. Further, pursuant to SEBI circular dated March 30, 2020, this phase has been extended till further notice.

**Phase III:** The commencement period of Phase III is yet to be notified. In this phase, the time duration from public issue closure to listing is proposed to be reduced to three Working Days. Accordingly, upon commencement of Phase III, the reduced time duration shall be applicable for the Offer.

The Offer will be made under UPI Phase II of the UPI Circular, unless UPI Phase III of the UPI Circular becomes effective and applicable on or prior to the Bid/Offer Opening Date. If the Offer is made under UPI Phase III of the UPI Circular, the same will be advertised in all editions of Financial Express (a widely circulated English national daily newspaper), all editions of Jansatta (a widely circulated Hindi national daily newspaper) and all editions of Arthik Lipi (a widely circulated Bengali regional daily newspaper, Bengali being the regional language in West Bengal, where our Registered Office is located) on or prior to the Bid/ Offer Opening Date and such advertisement shall also be made available to the Stock Exchanges for the purpose of uploading on their websites.

All SCSBs offering the facility of making application in public issues shall also provide facility to make application using UPI. Our Company will be required to appoint one of the SCSBs as a sponsor bank to act as a conduit between the Stock Exchanges and NPCI in order to facilitate collection of requests and/or payment instructions of the Retail Individual Investors using the UPI.

For further details, refer to the General Information Document available on the websites of the Stock Exchanges and the BRLMs.

### **Electronic registration of Bids**

- a) The Designated Intermediary may register the Bids using the online facilities of the Stock Exchanges. The Designated Intermediaries can also set up facilities for off-line electronic registration of Bids, subject to the condition that they may subsequently upload the off-line data file into the online facilities for Book Building on a regular basis before the closure of the Offer.
- b) On the Bid/ Offer Closing Date, the Designated Intermediaries may upload the Bids till such time as may be permitted by the Stock Exchanges and as disclosed in the Red Herring Prospectus.
- c) Only Bids that are uploaded on the Stock Exchanges Platform are considered for allocation/ Allotment. The Designated Intermediaries are given till 1:00 pm on the next Working Day following the Bid/ Offer Closing Date to modify select fields uploaded in the Stock Exchanges' Platform during the Bid/ Offer Period after which the Stock Exchange(s) send the bid information to the Registrar to the Offer for further processing.

### **Bid cum Application Form**

Copies of the Bid cum Application Form (other than for Anchor Investors) and the abridged prospectus will be available with the Designated Intermediaries at the Bidding Centres, and our Registered Office. An electronic copy of the Bid cum Application Form will also be available for download on the websites of BSE ([www.bseindia.com](http://www.bseindia.com)) and NSE ([www.nseindia.com](http://www.nseindia.com)) at least one day prior to the Bid/ Offer Opening Date.

All Bidders (other than Anchor Investors) shall mandatorily participate in the Offer only through the ASBA process. ASBA Bidders must provide either (i) the bank account details and authorisation to block funds in the ASBA Form, or (ii) the UPI ID, as applicable, in the relevant space provided in the ASBA Form. The ASBA Forms that do not contain such details are liable to be rejected. Applications made by the RIIs using third party bank account or using third party linked bank account UPI ID are liable for rejection. Anchor Investors are not permitted to participate in the Offer through the ASBA process. ASBA Bidders shall ensure that the Bids are made on ASBA Forms bearing the stamp of the relevant Designated Intermediary, submitted at the relevant Bidding Centres only (except in case of electronic ASBA Forms) and the ASBA Forms not bearing such specified stamp are liable to be rejected. Since the Offer is made under Phase II of the UPI Circulars, ASBA Bidders may submit the ASBA Form in the manner below:

- (i) RIIs (other than the RIIs using UPI Mechanism) may submit their ASBA Forms with SCSBs (physically or online, as applicable), or online using the facility of linked online trading, demat and bank account (3 in 1 type accounts), provided by certain brokers.
- (ii) RIIs using the UPI Mechanism, may submit their ASBA Forms with the Syndicate, sub-syndicate members, Registered Brokers, RTAs or CDPs, or online using the facility of linked online trading, demat and bank account (3 in 1 type accounts), provided by certain brokers.

- (iii) QIBs and NIBs may submit their ASBA Forms with SCSBs, Syndicate, sub-syndicate members, Registered Brokers, RTAs or CDPs.

ASBA Bidders are also required to ensure that the ASBA Account has sufficient credit balance as an amount equivalent to the full Bid Amount which can be blocked by the SCSB. In order to ensure timely information to investors, SCSBs are required to send SMS alerts to investors intimating them about Bid Amounts blocked/unblocked.

Investors must ensure that their PAN is linked with aadhaar and are in compliance with CBDT notification dated February 13, 2020 and press release dated June 25, 2021.

For Anchor Investors, the Anchor Investor Application Form will be available at the offices of the BRLMs. Anchor Investors are not permitted to participate in the Offer through the ASBA process.

The prescribed colour of the Bid cum Application Form for the various categories is as follows:

Category	Colour of Bid cum Application Form*
Resident Indians, including resident QIBs, Non-Institutional Investors, Retail Individual Investors and Eligible NRIs applying on a non-repatriation basis <sup>^</sup>	White
Eligible NRIs, FVCIs, FPIs and registered bilateral and multilateral institutions applying on a repatriation basis	Blue
Anchor Investors <sup>^^</sup>	White

<sup>\*</sup>Excluding the electronic Bid cum Application Form

<sup>^</sup>Electronic Bid cum Application Form will be made available for download on the website of the BSE ([www.bseindia.com](http://www.bseindia.com)) and NSE ([www.nseindia.com](http://www.nseindia.com))

<sup>^^</sup>Bid cum Application Forms for Anchor Investors were made available at the offices of the BRLMs.

<sup>#</sup>Bid cum Application Forms for Eligible Employees shall be available at the Registered Office of the Company.

The relevant Designated Intermediaries shall upload the relevant bid details in the electronic bidding system of the Stock Exchanges. For RIIs using the UPI Mechanism, the Stock Exchanges shall share the Bid details (including UPI ID) with the Sponsor Bank on a continuous basis to enable the Sponsor Bank to initiate UPI Mandate Request to RIIs for blocking of funds.

In case of ASBA forms, the relevant Designated Intermediaries shall capture and upload the relevant bid details (including UPI ID in case of ASBA Forms under the UPI Mechanism) in the electronic bidding system of the Stock Exchanges.

For RIIs Bidding using UPI Mechanism, the Stock Exchanges shall share the Bid details (including UPI ID) with the Sponsor Bank on a continuous basis through API integration to enable the Sponsor Bank to initiate UPI Mandate Request to RIIs, for blocking of funds. The Sponsor Bank shall initiate request for blocking of funds through NPCI to RIIs, who shall accept the UPI Mandate Request for blocking of funds on their respective mobile applications associated with UPI ID linked bank account. For all pending UPI Mandate Requests, the Sponsor Bank shall initiate requests for blocking of funds in the ASBA Accounts of relevant Bidders with a confirmation cut-off time of 12:00 pm on the first Working Day after the Bid/ Issue Closing Date (“**Cut-Off Time**”). Accordingly, RIIs Bidding using through the UPI Mechanism should accept UPI Mandate Requests for blocking off funds prior to the Cut-Off Time and all pending UPI Mandate Requests at the Cut-Off Time shall lapse.

For ASBA Forms (other than RIIs Bidding using UPI Mechanism) Designated Intermediaries (other than SCSBs) shall submit/deliver the ASBA Forms to the respective SCSB where the Bidder has an ASBA bank account and shall not submit it to any non-SCSB bank or any Escrow Collection Bank.

**The Equity Shares offered in the Offer have not been and will not be registered under the U.S. Securities Act or any state securities laws in the United States, and unless so registered, may not be offered or sold within the United States, except pursuant to an exemption from, or in a transaction not subject to, the registration requirements of the U.S. Securities Act and in accordance with any applicable U.S. state securities laws. Accordingly, the Equity Shares are being offered and sold outside the United States in ‘offshore transactions’ as defined in, and in reliance on, Regulation S under the U.S. Securities Act and the applicable laws of the jurisdictions where such offers and sales are made.**

**The Equity Shares have not been and will not be registered, listed or otherwise qualified in any other jurisdiction outside India and may not be offered or sold, and Bids may not be made by persons in any such jurisdiction, except in compliance with the applicable laws of such jurisdiction.**

### **Participation by the BRLMs, the Syndicate Members and their associates and affiliates**

The BRLMs and the Syndicate Members shall not be allowed to purchase Equity Shares in this Offer in any manner, except towards fulfilling their respective underwriting obligations. However, the associates and affiliates of the BRLMs and the Syndicate Members may Bid for Equity Shares in the Offer, either in the QIB Category or in the Non-Institutional Portion as may be applicable to such Bidders, where the allocation is on a proportionate basis, and such subscription may be on their own account or on behalf of their clients. All categories of investors, including associates or affiliates of the BRLMs and Syndicate Members, shall be treated equally for the purpose of allocation to be made on a proportionate basis.

Except as stated below, neither the BRLMs nor any persons related to the BRLMs can apply in the Offer under the Anchor Investor Portion:

- (i) mutual funds sponsored by entities which are associate of the BRLMs;
- (ii) insurance companies promoted by entities which are associate of the BRLMs;
- (iii) AIFs sponsored by the entities which are associate of the BRLMs;
- (iv) FPIs other than individuals, corporate bodies and family offices sponsored by the entities which are associate of the BRLMs; or
- (v) Person related to Promoters and the members of the Promoter Group.

Further, an Anchor Investor shall be deemed to be an “associate of the BRLM” if:

- (i) either of them controls, directly or indirectly through its subsidiary or holding company, not less than 15% of the voting rights in the other; or
- (ii) either of them, directly or indirectly, by itself or in combination with other persons, exercises control over the other; or
- (iii) there is a common director, excluding nominee director, amongst the Anchor Investors and the BRLMs.

### **Bids by Mutual Funds**

With respect to Bids by Mutual Funds, a certified copy of their SEBI registration certificate must be lodged with the Bid cum Application Form. Failing this, our Company and the Selling Shareholders reserves the right to reject any Bid without assigning any reason thereof. Bids made by asset management companies or custodians of Mutual Funds shall specifically state names of the concerned schemes for which such Bids are made.

**In case of a Mutual Fund, a separate Bid can be made in respect of each scheme of the Mutual Fund registered with SEBI and such Bids in respect of more than one scheme of the Mutual Fund will not be treated as multiple Bids provided that the Bids clearly indicate the scheme concerned for which the Bid has been made.**

**No Mutual Fund scheme shall invest more than 10% of its net asset value in equity shares or equity related instruments of any single company provided that the limit of 10% shall not be applicable for investments in case of index funds or sector or industry specific schemes. No Mutual Fund under all its schemes should own more than 10% of our Company’s paid-up share capital carrying voting rights.**

### **Bids by Eligible NRIs**

Eligible NRIs may obtain copies of Bid cum Application Form from the Designated Intermediaries. Eligible NRI Bidders bidding on a repatriation basis by using the Non-Resident forms should authorise their SCSSB to block their Non-Resident External (“NRE”) accounts (including UPI ID, if activated), or Foreign Currency Non-Resident (“FCNR”) accounts, and eligible NRI Bidders bidding on a non-repatriation basis by using resident forms should authorise their SCSSB to block their Non-Resident Ordinary (“NRO”) accounts for the full Bid Amount, at the time of the submission of the Bid cum Application Form.

Eligible NRIs Bidding on non-repatriation basis are advised to use the Bid cum Application Form for residents (white in colour). Eligible NRIs Bidding on a repatriation basis are advised to use the Bid cum Application Form meant for Non-Residents (blue in colour).

Participation of Eligible NRIs in the Offer shall be subject to the FEMA Rules. Only bids accompanied by payment in Indian rupees or fully convertible foreign exchange will be considered for allotment.

For details of restrictions on investment by NRIs, see “*Restrictions on Foreign Ownership of Indian Securities*” beginning on page 397.

### **Bids by HUFs**

Bids by Hindu Undivided Families or HUFs, in the individual name of the Karta. The Bidder should specify that the Bid is being made in the name of the HUF in the Bid cum Application Form as follows: “Name of sole or First Bidder: XYZ Hindu Undivided Family applying through XYZ, where XYZ is the name of the Karta”. Bids by HUFs may be considered at par with Bids from individuals.

### **Bids by FPIs**

In terms of the SEBI FPI Regulations, the issue of Equity Shares to a single FPI including its investor group (which means the same multiple entities having common ownership directly or indirectly of more than 50% or common control) must be below 10% of our post-Offer Equity Share capital. Further, in terms of the FEMA Regulations, the total holding by each FPI, of an investor group, shall be below 10% of the total paid-up Equity Share capital of our Company on a fully diluted basis and the total holdings of all FPIs could be up to 100%, being the sectoral cap, of the paid-up Equity Share capital of our Company on a fully diluted basis.

In case of Bids made by FPIs, a certified copy of the certificate of registration issued under the SEBI FPI Regulations is required to be attached to the Bid cum Application Form, failing which our Company reserves the right to reject any Bid without assigning any reason. FPIs who wish to participate in the Offer are advised to use the Bid cum Application Form for Non-Residents (blue in colour).

In terms of the FEMA Regulations, for calculating the aggregate holding of FPIs in a company, holding of all registered FPIs shall be included.

With effect from April 1, 2020, the aggregate limits for FPI investments are the sectoral caps applicable to our Company (i.e. up to 100% under the automatic route).

The FEMA Non-Debt Instruments Rules was enacted on October 17, 2019 in supersession of the Foreign Exchange Management (Transfer or Issue of Security by a Person Resident Outside India) Regulations, 2017, except as respects things done or omitted to be done before such supersession. FPIs are permitted to participate in the Offer subject to compliance with conditions and restrictions which may be specified by the Government from time to time.

To ensure compliance with the above requirement, SEBI, pursuant to its circular dated July 13, 2018, has directed that at the time of finalisation of the Basis of Allotment, the Registrar shall (i) use the PAN issued by the Income Tax Department of India for checking compliance for a single FPI; and (ii) obtain validation from Depositories for the FPIs who have invested in the Offer to ensure there is no breach of the investment limit, within the timelines for issue procedure, as prescribed by SEBI from time to time.

Subject to compliance with all applicable Indian laws, rules, regulations, guidelines and approvals in terms of the SEBI FPI Regulations, an FPI, may issue, subscribe to or otherwise deal in offshore derivative instruments (as defined under the SEBI FPI Regulations as any instrument, by whatever name called, which is issued overseas by a FPI against securities held by it in India, as its underlying) directly or indirectly, only in the event (i) such offshore derivative instruments are issued only by persons registered as Category I FPIs; (ii) such offshore derivative instruments are issued only to persons eligible for registration as Category I FPIs; (iii) such offshore derivative instruments are issued after compliance with ‘know your client’ norms; and (iv) such other conditions as may be specified by SEBI from time to time.

In case the total holding of an FPI increases beyond 10% of the total paid-up Equity Share capital, on a fully diluted basis or 10% or more of the paid-up value of any series of debentures or preference shares or share warrants issued that may be issued by our Company, the total investment made by the FPI will be re-classified as FDI subject to the conditions as specified by SEBI and RBI in this regard and our Company and the investor will be required to comply with applicable reporting requirements.



Subject to compliance with all applicable Indian laws, rules, regulations, guidelines and approvals in terms of the SEBI FPI Regulations, an FPI is permitted to issue, subscribe to, or otherwise deal in offshore derivative instruments, directly or indirectly, only if it complies with the following conditions:

- a) such offshore derivative instruments are issued only by persons registered as Category I FPIs;
- b) such offshore derivative instruments are issued only to persons eligible for registration as Category I FPIs;
- c) such offshore derivative instruments are issued after compliance with the 'know your client' norms as specified by SEBI; and
- d) such other conditions as may be specified by SEBI from time to time.

An FPI is required to ensure that the transfer of an offshore derivative instruments issued by or on behalf of it, is subject to (a) the transfer being made to persons which fulfil the criteria provided under the SEBI FPI Regulations (as mentioned above from points (a) to (d)); and (b) prior consent of the FPI is obtained for such transfer, except in cases, where the persons to whom the offshore derivative instruments are to be transferred, are pre-approved by the FPI.

Bids by following FPIs, submitted with the same PAN but with different beneficiary account numbers, Client IDs and DP IDs shall not be treated as multiple Bids:

- FPIs which utilise the multi investment manager (“MIM”) structure;
- Offshore derivative instruments which have obtained separate FPI registration for ODI and proprietary derivative investments;
- Sub funds or separate class of investors with segregated portfolio who obtain separate FPI registration;
- FPI registrations granted at investment strategy level/sub fund level where a collective investment scheme or fund has multiple investment strategies/sub-funds with identifiable differences and managed by a single investment manager;
- Multiple branches in different jurisdictions of foreign bank registered as FPIs;
- Government and Government related investors registered as Category 1 FPIs; and
- Entities registered as collective investment scheme having multiple share classes.

The Bids belonging to any of the above mentioned seven structures and having same PAN may be collated and identified as a single Bid in the Bidding process. The Equity Shares allotted in the Bid may be proportionately distributed to the applicant FPIs (with same PAN). In order to ensure valid Bids, FPIs making multiple Bids using the same PAN, and with different beneficiary account numbers, Client IDs and DP IDs, are required to provide a confirmation along with each of their Bid cum Application Forms that the relevant FPIs making multiple Bids utilize any of the above-mentioned structures and indicate the name of their respective investment managers in such confirmation. In the absence of such confirmation from the relevant FPIs, such multiple Bids shall be rejected.

The FPIs who wish to participate in the Offer are advised to use the Bid cum Application Form for non-residents.

#### **Bids by SEBI registered VCFs, AIFs and FVCIs**

The SEBI FVCI Regulations, *inter alia*, prescribe the investment restrictions on VCFs and FVCIs registered with SEBI. Further, the SEBI AIF Regulations prescribe, amongst others, the investment restrictions on AIFs. Accordingly, the holding in any company by any individual VCF or FVCI registered with SEBI should not exceed 25% of the corpus of the VCF or FVCI. Further, VCFs and FVCIs can invest only up to 33.33% of the investible funds in various prescribed instruments, including in public offerings.

Category I AIFs and Category II AIFs cannot invest more than 25% of the investible funds in one investee company. A category III AIF cannot invest more than 10% of the investible funds in one investee company. A VCF registered as a Category I AIF, as defined in the SEBI AIF Regulations, cannot invest more than one-third

of its investible funds by way of subscription to an initial public offering of a venture capital undertaking. Pursuant to the repeal of the SEBI VCF Regulations, the VCFs which have not re-registered as an AIF under the SEBI AIF Regulations shall continue to be regulated by the SEBI VCF Regulations until the existing fund or scheme managed by the fund is wound up and such fund shall not launch any new scheme after the notification of the SEBI AIF Regulations. Our Company, the Selling Shareholders, and the BRLMs will not be responsible for loss, if any, incurred by the Bidder on account of conversion of foreign currency.

Participation of VCFs, AIFs or FVCIs in the Offer shall be subject to the FEMA Rules, amended from time to time.

**All non-resident investors should note that refunds (in case of Anchor Investors), dividends and other distributions, if any, will be payable in Indian Rupees only and net of bank charges and commission.**

**Our Company, the Selling Shareholder or the BRLMs will not be responsible for loss, if any, incurred by the Bidder on account of conversion of foreign currency.**

#### **Bids by Limited Liability Partnerships**

In case of Bids made by limited liability partnerships registered under the Limited Liability Partnership Act, 2008, a certified copy of certificate of registration issued under the Limited Liability Partnership Act, 2008, must be attached to the Bid cum Application Form. Failing this, our Company and the Selling Shareholders in consultation with the BRLMs reserve the right to reject any Bid without assigning any reason thereof.

#### **Bids by banking companies**

In case of Bids made by banking companies registered with the RBI, certified copies of (i) the certificate of registration issued by the RBI, and (ii) the approval of such banking company's investment committee are required to be attached to the Bid cum Application Form. Failing this, our Company and the Selling Shareholders, in consultation with the BRLMs, reserves the right to reject any Bid without assigning any reason thereof, subject to applicable law.

The investment limit for banking companies in non-financial services companies as per the Banking Regulation Act, 1949, as amended, (the "**Banking Regulation Act**"), and the Master Directions - Reserve Bank of India (Financial Services provided by Banks) Directions, 2016, as amended, is 10% of the paid-up share capital of the investee company. Further, a banking company is restricted from holding more than 10% of the its own paid-up share capital not being its subsidiary engaged in non-financial services or 10 per cent of the bank's paid up capital and reserve, whichever is lower. Further, the aggregate equity investment by a banking company in all subsidiaries and other entities engaged in financial services company and non-financial services, including overseas investments cannot exceed 20% of the investee company's paid up share capital and reserves. However, a banking company would be permitted to invest in excess of 10% but not exceeding 30% of the paid-up share capital of such investee company if (i) the investee company is engaged in non-financial activities permitted for banks in terms of Section 6(1) of the Banking Regulation Act, or (ii) the additional acquisition is through restructuring of debt/corporate debt restructuring/strategic debt restructuring, or to protect the bank's interest on loans/investments made to a company. The bank is required to submit a time-bound action plan for disposal of such shares within a specified period to the RBI. A banking company would require a prior approval of the RBI to make investment in a subsidiary and a financial services company that is not a subsidiary (with certain exceptions prescribed), and investment in a non-financial services company in excess of 10% of such investee company's paid-up share capital as stated in 5(a)(v)(c)(i) of the Reserve Bank of India (Financial Services provided by Banks) Directions, 2016, as amended.

#### **Bids by SCSBs**

SCSBs participating in the Offer are required to comply with the terms of the circulars bearing numbers CIR/CFD/DIL/12/2012 and CIR/CFD/DIL/1/2013 dated September 13, 2012 and January 2, 2013, respectively, issued by SEBI. Such SCSBs are required to ensure that for making applications on their own account using ASBA, they should have a separate account in their own name with any other SEBI registered SCSBs. Further, such account shall be used solely for the purpose of making application in public issues and clear demarcated funds should be available in such account for such applications.

### **Bids by Insurance Companies**

In case of Bids made by insurance companies registered with the IRDAI, a certified copy of certificate of registration issued by IRDAI must be attached to the Bid cum Application Form. Failing this, our Company and the Selling Shareholders, in consultation with the BRLMs reserve the right to reject any Bid without assigning any reason thereof, subject to applicable law.

The exposure norms for insurers are prescribed under the Insurance Regulatory and Development Authority of India (Investment) Regulations, 2016, as amended (“**IRDAI Investment Regulations**”), based on investments in the equity shares of a company, the entire group of the investee company and the industry sector in which the investee company operates. Insurance companies participating in the Offer are advised to refer to the IRDAI Investment Regulations for specific investment limits applicable to them and shall comply with all applicable regulations, guidelines and circulars issued by IRDAI from time to time.

### **Bids by Provident Funds/Pension Funds**

In case of Bids made by provident funds/pension funds with minimum corpus of ₹250 million, subject to applicable law, a certified copy of a certificate from a chartered accountant certifying the corpus of the provident fund/pension fund must be attached to the Bid cum Application Form. Failing this, our Company and the Selling Shareholders, in consultation with the BRLMs reserve the right to reject any Bid, without assigning any reason thereof.

### **Bids by Systemically Important Non-Banking Financial Companies**

In case of Bids made by Systemically Important Non-Banking Financial Companies registered with RBI, certified copies of: (i) the certificate of registration issued by RBI, (ii) certified copy of its last audited financial statements on a standalone basis, (iii) a net worth certificate from its statutory auditor, and (iv) such other approval as may be required by the Systemically Important Non-Banking Financial Companies, are required to be attached to the Bid cum Application Form. Failing this, our Company and the Selling Shareholders, in consultation with the BRLMs, reserves the right to reject any Bid without assigning any reason thereof, subject to applicable law. Systemically Important NBFCs participating in the Offer shall comply with all applicable regulations, guidelines and circulars issued by RBI from time to time.

The investment limit for Systemically Important NBFCs shall be as prescribed by RBI from time to time.

**The information set out above is given for the benefit of the Bidders. Our Company, the Selling Shareholders, and the BRLMs are not liable for any amendments or modification or changes to applicable laws or regulations, which may occur after the date of this Red Herring Prospectus. Bidders are advised to make their independent investigations and ensure that any single Bid from them does not exceed the applicable investment limits or maximum number of the Equity Shares that can be held by them under applicable law or regulations, or as specified in this Red Herring Prospectus, the Red Herring Prospectus and the Prospectus.**

### **Bids under Power of Attorney**

In case of Bids made pursuant to a power of attorney by limited companies, corporate bodies, registered societies, eligible FPIs, AIFs, Mutual Funds, insurance companies, NBFC-SI, insurance funds set up by the army, navy or air force of the India, insurance funds set up by the Department of Posts, India or the National Investment Fund and provident funds with a minimum corpus of ₹250.00 million (subject to applicable laws) and pension funds with a minimum corpus of ₹250.00 million, a certified copy of the power of attorney or the relevant resolution or authority, as the case may be, along with a certified copy of the memorandum of association and articles of association and/or bye laws must be lodged along with the Bid cum Application Form. Failing this, our Company and the reserve the right to accept or reject any Bid in whole or in part, in either case, without assigning any reason thereof.

Our Company and Selling Shareholders in consultation with the BRLMs, in their absolute discretion, reserve the right to relax the above condition of simultaneous lodging of the power of attorney along with the Bid cum Application Form, subject to such terms and conditions that our Company and Selling Shareholders in consultation with the BRLMs, may deem fit.

## Bids by Anchor Investors

- (a) In accordance with the SEBI ICDR Regulations, in addition to details and conditions mentioned in this section the key terms for participation by Anchor Investors are provided below. Anchor Investor Application Forms will be made available for the Anchor Investor Portion at the offices of the BRLMs.
- (b) The Bid must be for a minimum of such number of Equity Shares so that the Bid Amount exceeds ₹100.00 million. A Bid cannot be submitted for over 60% of the QIB Portion. In case of a Mutual Fund, separate bids by individual schemes of a Mutual Fund will be aggregated to determine the minimum application size of ₹100.00 million.
- (c) One-third of the Anchor Investor Portion will be reserved for allocation to domestic Mutual Funds.
- (d) Bidding for Anchor Investors will open one Working Day before the Bid/ Offer Opening Date, and will be completed on the same day.
- (e) Our Company and the Selling Shareholders, in consultation with the BRLMs may finalise allocation to the Anchor Investors on a discretionary basis, provided that the minimum number of Allottees in the Anchor Investor Portion will not be less than:
  - (i) maximum of two Anchor Investors, where allocation under the Anchor Investor Portion is up to ₹100.00 million;
  - (ii) minimum of two and maximum of 15 Anchor Investors, where the allocation under the Anchor Investor Portion is more than ₹100.00 million but up to ₹2,500.00 million, subject to a minimum Allotment of ₹50.00 million per Anchor Investor; and
  - (iii) in case of allocation above ₹2,500.00 million under the Anchor Investor Portion, a minimum of five such investors and a maximum of 15 Anchor Investors for allocation up to ₹2,500.00 million, and an additional 10 Anchor Investors for every additional ₹2,500.00 million, subject to minimum Allotment of ₹50.00 million per Anchor Investor.
- (f) Allocation to Anchor Investors will be completed on the Anchor Investor Bid/ Offer Period. The number of Equity Shares allocated to Anchor Investors and the price at which the allocation is made, will be made available in the public domain by the BRLMs before the Bid/ Offer Opening Date, through intimation to the Stock Exchanges.
- (g) Anchor Investors cannot withdraw or lower the size of their Bids at any stage after submission of the Bid.
- (h) If the Offer Price is greater than the Anchor Investor Allocation Price, the additional amount being the difference between the Offer Price and the Anchor Investor Offer Price will be payable by the Anchor Investors on the Anchor Investor pay-in date specified in the CAN. If the Offer Price is lower than the Anchor Investor Offer Price, Allotment to successful Anchor Investors will be at the higher price.
- (i) Equity Shares Allotted in the Anchor Investor Portion will be locked in for a period of 30 days from the date of Allotment.
- (j) Neither the BRLMs nor any associate of the BRLMs (except Mutual Funds sponsored by entities which are associates of the BRLMs or insurance companies promoted by entities which are associate of BRLMs or AIFs sponsored by the entities which are associate of the BRLMs or FPIs, other than individuals, corporate bodies and family offices sponsored by the entities which are associate of the and BRLMs) shall apply in the Offer under the Anchor Investor Portion. For details, see “- *Participation by the BRLMs, the Syndicate Members and their associates and affiliates*” on page 384.
- (k) Bids made by QIBs under both the Anchor Investor Portion and the QIB Portion will not be considered multiple Bids.

**The above information is given for the benefit of the Bidders. Our Company, the Selling Shareholders and the BRLMs are not liable for any amendments or modification or changes in applicable laws or regulations, which may occur after the date of this Red Herring Prospectus. Bidders are advised to make their independent investigations and ensure that any single Bid from them does not exceed the applicable**

**investment limits or maximum number of the Equity Shares that can be held by them under applicable law or regulation or as specified in this Red Herring Prospectus.**

### **General Instructions**

Please note that QIBs and Non-Institutional Bidders are not permitted to withdraw their Bid(s) or lower the size of their Bid(s) (in terms of quantity of Equity Shares or the Bid Amount) at any stage. RIIs can revise their Bid(s) during the Bid/ Offer Period and withdraw or lower the size of their Bid(s) until Bid/ Offer Closing Date. Anchor Investors are not allowed to withdraw their Bids after the Anchor Investor Bid/ Offer Period.

#### ***Do's:***

1. Check if you are eligible to apply as per the terms of this Red Herring Prospectus and under applicable law, rules, regulations, guidelines and approvals. All Bidders (other than Anchor Investors) should submit their Bids through the ASBA process only;
2. Investors must ensure that their PAN is linked with aadhaar and are in compliance with CBDT notification dated February 13, 2020 and press release dated June 25, 2021.
3. Ensure that you have Bid within the Price Band;
4. Read all the instructions carefully and complete the Bid cum Application Form in the prescribed form;
5. Ensure that you (other than the Anchor Investors) have mentioned the correct details of ASBA Account (i.e. bank account number or UPI ID, as applicable) and PAN in the Bid cum Application Form;
6. Ensure that your Bid cum Application Form bearing the stamp of a Designated Intermediary is submitted to the Designated Intermediary at the relevant Bidding Centre (except in case of electronic Bids) within the prescribed time;
7. RIIs Bidding in the Offer shall ensure that they use only their own ASBA Account or only their own bank account linked UPI ID (only for RIIs using the UPI Mechanism) to make an application in the Offer and not ASBA Account or bank account linked UPI ID of any third party;
8. Ensure that you have funds equal to the Bid Amount in the ASBA Account maintained with the SCSB before submitting the ASBA Form to the relevant Designated Intermediaries;
9. Ensure that the signature of the first Bidder in case of joint Bids, is included in the Bid cum Application Forms. If the first Bidder is not the ASBA Account holder, ensure that the Bid cum Application Form is also signed by the ASBA Account holder;
10. Ensure that the names given in the Bid cum Application Form is/are exactly the same as the names in which the beneficiary account is held with the Depository Participant. In case of joint Bids, the Bid cum Application Form should contain the name of only the first Bidder whose name should also appear as the first holder of the beneficiary account held in joint names;
11. Ensure that you request for and receive a stamped acknowledgement in the form of a counterfoil of the Bid cum Application Form for all your Bid options from the concerned Designated Intermediary;
12. Ensure that you submit the revised Bids to the same Designated Intermediary, through whom the original Bid was placed and obtain a revised acknowledgment;
13. Except for Bids (i) on behalf of the Central or State Governments and the officials appointed by the courts, who, in terms of the circular no. MRD/DoP/Cir-20/2008 dated June 30, 2008 issued by SEBI, may be exempt from specifying their PAN for transacting in the securities market, (ii) Bids by persons resident in the state of Sikkim, who, in terms of the circular dated July 20, 2006 issued by SEBI, may be exempted from specifying their PAN for transacting in the securities market, and (iii) persons/entities exempt from holding a PAN under applicable law, all Bidders should mention their PAN allotted under the IT Act. The exemption for the Central or the State Government and officials appointed by the courts and for investors residing in the State of Sikkim is subject to (a) the Demographic Details received from the respective depositories confirming the exemption granted to the beneficial owner by a suitable description in the PAN field and the beneficiary account remaining in "active status"; and (b) in the case

of residents of Sikkim, the address as per the Demographic Details evidencing the same. All other applications in which PAN is not mentioned will be rejected;

14. Ensure that thumb impressions and signatures other than in the languages specified in the Eighth Schedule to the Constitution of India are attested by a Magistrate or a Notary Public or a Special Executive Magistrate under official seal;
15. Ensure that the category and the investor status is indicated in the Bid cum Application Form to ensure proper upload of your Bid in the electronic Bidding system of the Stock Exchanges;
16. Ensure that in case of Bids under power of attorney or by limited companies, corporates, trust, etc., relevant documents including a copy of the power of attorney, if applicable, are submitted;
17. Ensure that Bids submitted by any person outside India is in compliance with applicable foreign and Indian laws;
18. However, Bids received from FPIs bearing the same PAN shall not be treated as multiple Bids in the event such FPIs utilise the MIM Structure and such Bids have been made with different beneficiary account numbers, Client IDs and DP IDs.
19. Since the Allotment will be in dematerialised form only, ensure that the depository account is active, the correct DP ID, Client ID, UPI ID (for RIIs bidding through UPI mechanism) and the PAN are mentioned in their Bid cum Application Form and that the name of the Bidder, the DP ID, Client ID, UPI ID (for RIIs bidding through UPI mechanism) and the PAN entered into the online IPO system of the Stock Exchanges by the relevant Designated Intermediary, as applicable, matches with the name, DP ID, Client ID, UPI ID (for RIIs bidding through UPI mechanism) and PAN available in the Depository database;
20. In case of QIBs and NIIs, ensure that while Bidding through a Designated Intermediary, the ASBA Form is submitted to a Designated Intermediary in a Bidding Centre and that the SCSB where the ASBA Account, as specified in the ASBA Form, is maintained has named at least one branch at that location for the Designated Intermediary to deposit ASBA Forms (a list of such branches is available on the website of SEBI at <http://www.sebi.gov.in>);
21. Ensure that you have correctly signed the authorisation/undertaking box in the Bid cum Application Form, or have otherwise provided an authorisation to the SCSB or the Sponsor Bank, as applicable, via the electronic mode, for blocking funds in the ASBA Account equivalent to the Bid Amount mentioned in the Bid cum Application Form at the time of submission of the Bid. In case of RIIs Bidding through the UPI Mechanism, ensure that you authorise the UPI Mandate Request raised by the Sponsor Bank for blocking of funds equivalent to Bid Amount and subsequent debit of funds in case of Allotment;
22. Ensure that the Demographic Details are updated, true and correct in all respects;
23. The ASBA Bidders shall use only their own bank account or only their own bank account linked UPI ID for the purposes of making Application in the Offer, which is UPI 2.0 certified by NPCI;
24. Bidders (except RIIs Bidding through the UPI Mechanism) should instruct their respective banks to release the funds blocked in the ASBA account under the ASBA process. In case of RIIs, once the Sponsor Bank issues the Mandate Request, the RIIs would be required to proceed to authorise the blocking of funds by confirming or accepting the UPI Mandate Request to authorise the blocking of funds equivalent to application amount and subsequent debit of funds in case of Allotment, in a timely manner;
25. Bidding through UPI Mechanism shall ensure that details of the Bid are reviewed and verified by opening the attachment in the UPI Mandate Request and then proceed to authorise the UPI Mandate Request using his/her UPI PIN. Upon the authorisation of the mandate using his/her UPI PIN, a RII Bidding through UPI Mechanism shall be deemed to have verified the attachment containing the application details of the RII Bidding through UPI Mechanism in the UPI Mandate Request and have agreed to block the entire Bid Amount and authorised the Sponsor Bank issue a request to block the Bid Amount specified in the Bid cum Application Form in his/her ASBA Account;
26. RIIs bidding using the UPI Mechanism should mention valid UPI ID of only the Bidder (in case of single account) and of the first Bidder (in case of joint account) in the Bid cum Application Form;

27. RIIs using the UPI Mechanism who have revised their Bids subsequent to making the initial Bid should also approve the revised UPI Mandate Request generated by the Sponsor Bank to authorise blocking of funds equivalent to the revised Bid Amount and subsequent debit of funds in case of Allotment in a timely manner.
28. Bids by Eligible NRIs HUFs and any individuals, corporate bodies and family offices which are recategorised as Category II FPI and registered with SEBI for a Bid Amount of less than ₹200,000 would be considered under the Retail Category for the purposes of allocation and Bids for a Bid Amount exceeding ₹200,000 would be considered under the Non-Institutional Category for allocation in the Offer; and
29. Ensure that Anchor Investors submit their Bid cum Application Forms only to the BRLMs.

The Bid cum Application Form is liable to be rejected if the above instructions, as applicable, are not complied with. Application made using incorrect UPI handle or using a bank account of an SCSB or SCSBs which is not mentioned in the Annexure 'A' to the SEBI circular no. SEBI/HO/CFD/DIL2/CIR/P/2019/85 dated July 26, 2019 is liable to be rejected.

***Don'ts:***

1. Do not Bid for lower than the minimum Bid Lot;
2. Do not submit a Bid using UPI ID, if you are not a RII;
3. Do not Bid for a Bid Amount exceeding ₹200,000 for Bids by Retail Individual Investors and ₹500,000.00 for Bids by Eligible Employees;
4. Do not Bid on another Bid cum Application Form and the Anchor Investor Application Form, as the case may be, after you have submitted a Bid to any of the Designated Intermediary;
5. Do not Bid/ revise the Bid amount to less than the floor price or higher than the cap price;
6. Do not pay the Bid Amount in cheques, demand drafts or by cash, money order, postal order or by stock invest;
7. Do not send Bid cum Application Forms by post; instead submit the same to the Designated Intermediary only;
8. Do not Bid at Cut-off Price (for Bids by QIBs and Non-Institutional Bidders);
9. Do not instruct your respective banks to release the funds blocked in the ASBA Account under the ASBA process;
10. Do not submit the Bid for an amount more than funds available in your ASBA account;
11. Do not submit Bids on plain paper or on incomplete or illegible Bid cum Application Forms or on Bid cum Application Forms in a colour prescribed for another category of Bidder;
12. Do not submit a Bid in case you are not eligible to acquire Equity Shares under applicable law or your relevant constitutional documents or otherwise;
13. Do not Bid if you are not competent to contract under the Indian Contract Act, 1872 (other than minors having valid depository accounts as per Demographic Details provided by the depository);
14. Do not fill up the Bid cum Application Form such that the Equity Shares Bid for exceeds the Offer size and/or investment limit or maximum number of the Equity Shares that can be held under the applicable laws or regulations or maximum amount permissible under the applicable regulations or under the terms of this Red Herring Prospectus;
15. Do not Bid for Equity Shares more than specified by the respective Stock Exchanges for each category;
16. In case of ASBA Bidders (other than RIIs using UPI mechanism), do not submit more than one Bid cum Application Form per ASBA Account;

17. If you are RII and are using UPI mechanism, do not submit more than one Bid cum Application Form for each UPI ID;
18. Do not make the Bid cum Application Form using third party bank account or using third party linked bank account UPI ID;
19. Anchor Investors should not bid through the ASBA process;
20. Do not submit the Bid cum Application Form to any non-SCSB bank or our Company;
21. Do not Bid on another Bid cum Application Form and the Anchor Investor Application Form, as the case may be, after you have submitted a Bid to any of the Designated Intermediaries;
22. Do not submit the GIR number instead of the PAN;
23. Anchor Investors should submit Anchor Investor Application Form only to the BRLMs;
24. Do not Bid on a Bid cum Application Form that does not have the stamp of a Designated Intermediary;
25. Do not submit your Bid after 3 pm on the Bid/ Offer Closing Date;
26. If you are a QIB, do not submit your Bid after 3 p.m. on the QIB Bid/ Offer Closing Date;
27. Do not withdraw your Bid or lower the size of your Bid (in terms of quantity of the Equity Shares or the Bid Amount) at any stage, if you are a QIB or a Non-Institutional Bidder. Retail Individual Investors can revise or withdraw their Bids on or before the Bid/ Offer Closing Date;
28. Do not submit Bids to a Designated Intermediary at a location other than at the relevant Bidding Centres. If you are RII and are using UPI mechanism, do not submit the ASBA Form directly with SCSBs;
29. Do not submit incorrect details of the DP ID, Client ID, PAN and UPI ID details if you are a RII Bidding through the UPI Mechanism. Further, do not provide details for a beneficiary account which is suspended or for which details cannot be verified to the Registrar to the Offer;
30. Do not submit the Bid without ensuring that funds equivalent to the entire Bid Amount are available for blocking in the relevant ASBA account;
31. Do not link the UPI ID with a bank account maintained with a bank that is not UPI 2.0 certified by the NPCI in case of Bids submitted by RIIs using the UPI Mechanism;
32. RIIs Bidding through the UPI Mechanism using the incorrect UPI handle or using a bank account of an SCSB or a banks which is not mentioned in the list provided in the SEBI website is liable to be rejected; and
33. Do not submit more than one Bid cum Application Form for each UPI ID in case of RIIs Bidding using the UPI Mechanism.
34. Do not Bid if you are an OCB.

The Bid cum Application Form is liable to be rejected if the above instructions, as applicable, are not complied with.

Further, in case of any pre-issue or post issue related issues regarding share certificates/ demat credit/ refund orders/ unblocking, etc., investors shall reach out the Compliance Officer. For details of the Compliance Officer, see "**General Information**" beginning on page 66.

In case of any delay in unblocking of amounts in the ASBA Accounts (including amounts blocked through the UPI Mechanism) exceeding four Working Days from the Bid/ Offer Closing Date, the Bidder shall be compensated at a uniform rate of ₹100 per day for the entire duration of delay exceeding four Working Days from the Bid/ Offer Closing Date by the intermediary responsible for causing such delay in unblocking. The BRLMs shall, in their sole discretion, identify and fix the liability on such intermediary or entity responsible for such delay in unblocking.



For details of grounds for technical rejections of a Bid cum Application Form, please see the General Information Document.

#### **Names of entities responsible for finalising the basis of allotment in a fair and proper manner**

The authorised employees of the Stock Exchanges, along with the BRLMs and the Registrar to the Offer, shall ensure that the Basis of Allotment is finalised in a fair and proper manner in accordance with the procedure specified in SEBI ICDR Regulations.

#### **Method of allotment as may be prescribed by SEBI from time to time**

Our Company will not make any allotment in excess of the Equity Shares offered through the Offer through the offer document except in case of oversubscription for the purpose of rounding off to make allotment, in consultation with the Designated Stock Exchange. Further, upon oversubscription, an allotment of not more than 1% of the Offer to public may be made for the purpose of making allotment in minimum lots.

The allotment of Equity Shares to applicants other than to the RIIs and Anchor Investors shall be on a proportionate basis within the respective investor categories and the number of securities allotted shall be rounded off to the nearest integer, subject to minimum allotment being equal to the minimum application size as determined and disclosed.

The allotment of Equity Shares to each RII shall not be less than the minimum bid lot, subject to the availability of shares in RII category, and the remaining available shares, if any, shall be allotted on a proportionate basis.

#### **Payment into Anchor Investor Escrow Account**

Our Company and the Selling Shareholders, in consultation with the BRLMs will decide the list of Anchor Investors to whom the CAN will be sent, pursuant to which, the details of the Equity Shares allocated to them in their respective names will be notified to such Anchor Investors. For Anchor Investors, the payment instruments for payment into the Anchor Investor Escrow Account should be drawn in favour of:

- (a) In case of resident Anchor Investors: “TEGA INDUSTRIES LIMITED - IPO – ANCHOR INVESTOR - R”
- (b) In case of Non-Resident Anchor Investors: “TEGA INDUSTRIES LIMITED - IPO – ANCHOR INVESTOR - NR”

Anchor Investors should note that the escrow mechanism is not prescribed by SEBI and has been established as an arrangement between our Company, the Selling Shareholders, the Syndicate, the Escrow Collection Bank and the Registrar to the Offer to facilitate collections of Bid amounts from Anchor Investors.

#### **Pre-Offer Advertisement**

Subject to Section 30 of the Companies Act, our Company shall, after filing the Red Herring Prospectus with the RoC, publish a pre-Offer advertisement, in the form prescribed under the SEBI ICDR Regulations, in all editions of Financial Express (a widely circulated English national daily newspaper), all editions of Jansatta (a widely circulated Hindi national daily newspaper) and all editions of Arthik Lipi (a widely circulated Bengali regional daily newspaper, Bengali being the regional language in West Bengal, where our Registered Office is located).

In the pre-Offer advertisement, we shall state the Bid/ Offer Opening Date and the Bid/ Offer Closing Date. This advertisement, subject to the provisions of Section 30 of the Companies Act, shall be in the format prescribed in Part A of Schedule X of the SEBI ICDR Regulations.

**The information set out above is given for the benefit of the Bidders/applicants. Our Company, the respective Selling Shareholders, and the BRLMs are not liable for any amendments or modification or changes in applicable laws or regulations, which may occur after the date of this Red Herring Prospectus. Bidders/applicants are advised to make their independent investigations and ensure that the number of Equity Shares Bid for do not exceed the prescribed limits under applicable laws or regulations.**

#### **Signing of the Underwriting Agreement and Filing with the RoC**

- (a) Our Company, the Selling Shareholders and the Underwriters intend to enter into an Underwriting Agreement after the finalisation of the Offer Price.
- (b) After signing the Underwriting Agreement, an updated Red Herring Prospectus will be filed with the RoC in accordance with applicable law, which would then be termed as the Prospectus. The Prospectus will contain details of the Offer Price, the Anchor Investor Offer Price, the Offer size, and underwriting arrangements and will be complete in all material respects.

### **Impersonation**

**Attention of the applicants is specifically drawn to the provisions of sub-section (1) of Section 38 of the Companies Act, which is reproduced below:**

***“Any person who:***

- (a) makes or abets making of an application in a fictitious name to a company for acquiring, or subscribing for, its securities; or***
- (b) makes or abets making of multiple applications to a company in different names or in different combinations of his name or surname for acquiring or subscribing for its securities; or***
- (c) otherwise induces directly or indirectly a company to allot, or register any transfer of, securities to him, or to any other person in a fictitious name,***

***shall be liable for action under Section 447.”***

The liability prescribed under Section 447 of the Companies Act, for fraud involving an amount of at least ₹1 million or 1% of the turnover of the Company, whichever is lower, includes imprisonment for a term which shall not be less than six months extending up to 10 years and fine of an amount not less than the amount involved in the fraud, extending up to three times such amount (provided that where the fraud involves public interest, such term shall not be less than three years.) Further, where the fraud involves an amount less than ₹1 million or one per cent of the turnover of the company, whichever is lower, and does not involve public interest, any person guilty of such fraud shall be punishable with imprisonment for a term which may extend to five years or with fine which may extend to ₹5.00 million or with both.

### **Undertakings by our Company**

Our Company undertakes the following:

- adequate arrangements shall be made to collect all Bid cum Application Forms submitted by Bidders;
- the complaints received in respect of the Offer shall be attended to by our Company expeditiously and satisfactorily;
- all steps for completion of the necessary formalities for listing and commencement of trading at all the Stock Exchanges where the Equity Shares are proposed to be listed are taken within six working days of the Bid/ Offer Closing Date or within such other time period prescribed by SEBI will be taken;
- the funds required for making refunds/unblocking (to the extent applicable) as per the mode(s) disclosed shall be made available to the Registrar to the Offer by our Company;
- if Allotment is not made within six working days from the Bid/ Offer Closing Date or such other prescribed timelines under applicable laws, the entire subscription amount received will be refunded/unblocked within the time prescribed under applicable laws. If there is a delay beyond such prescribed time, our Company shall pay interest prescribed under the Companies Act, the SEBI ICDR Regulations and other applicable laws for the delayed period;
- where refunds (to the extent applicable) are made through electronic transfer of funds, a suitable communication shall be sent to the applicant within time prescribed under applicable laws, giving details of the bank where refunds shall be credited along with amount and expected date of electronic credit of refund;

- that if our Company or the Selling Shareholders do not proceed with the Offer after the Bid/ Offer Closing Date but prior to Allotment, the reason thereof shall be given as a public notice within two days of the Bid/ Offer Closing Date. The public notice shall be issued in the same newspapers where the pre-Offer advertisements were published. The Stock Exchanges shall be informed promptly;
- that if our Company and the Selling Shareholders withdraw the Offer after the Bid/ Offer Closing Date, our Company shall be required to file a fresh offer document with SEBI, in the event our Company or the Selling Shareholders subsequently decide to proceed with the Offer;
- that, except any exercise of options vested pursuant to ESOP Schemes, no further issue of the Equity Shares shall be made till the Equity Shares offered through the Red Herring Prospectus are listed or until the Bid monies are refunded/unblocked in the relevant ASBA Accounts on account of non-listing, under-subscription, etc.; and
- that, except for any exercise of options vested pursuant to ESOP Schemes, no further issue of the Equity Shares shall be made till the Equity Shares offered through the Red Herring Prospectus are listed or until the Bid monies are refunded/unblocked in the relevant ASBA Accounts on account of non-listing, under-subscription, etc.; and
- adequate arrangements shall be made to collect all Bid cum Application Forms from Bidders.

#### **Undertakings by the Selling Shareholders**

Each Selling Shareholder, severally and not jointly, specifically undertakes and/or confirms the following in respect to itself and its respective portion of the Offered Shares:

- the Equity Shares offered by it in the Offer for Sale are eligible for being offered in the Offer for Sale in terms of Regulation 8 of the SEBI ICDR Regulations, are fully paid up (pursuant to the conversion of CCPP held by the Investor Selling Shareholder into Equity Shares) and shall be in dematerialized form at the time of transfer;
- it shall not sell, pledge, purchase or create any other encumbrance the Offered Shares until such time that the lock-in (if applicable) remains effective save and except as may be permitted under the SEBI ICDR Regulations;
- it is the legal and beneficial holder and has full title to its respective portion of the Offered Shares;
- it shall provide reasonable support and extend reasonable cooperation as required or requested by our Company and/ or the BRLMs for the purpose of redressal of such investor grievances, solely in relation to itself, and in relation to its portion of the Offered Shares;
- it shall provide reasonable assistance to our Company and the BRLMs in the taking of all steps as may be required for completion of the necessary formalities for listing and commencement of trading at the Stock Exchanges, in relation to the Offer, including in respect of the dispatch of refund orders or allotment advice or communications to bidders in relation to electronic refunds;
- its respective portion of the Offered Shares are free and clear of any encumbrances and shall be transferred to the Bidders within the time specified under applicable law; and
- it shall not access or have recourse to the money raised in the Offer for Sale until receipt by our Company of the final listing and trading approvals from all the Stock Exchanges in accordance with applicable law.

#### **Utilisation of Offer Proceeds**

Our Board and the Selling Shareholders, severally and not jointly, specifically confirm that all monies received out of the Offer shall be credited/transferred to a separate bank account other than the bank account referred to in sub-Section (3) of Section 40 of the Companies Act, 2013.

## RESTRICTION ON FOREIGN OWNERSHIP OF INDIAN SECURITIES

Foreign investment in Indian securities is regulated through the FEMA, the Consolidated FDI Policy and the circulars and notifications issued thereunder. Unless specifically restricted, foreign investment is freely permitted in all sectors of the Indian economy, subject to certain applicable pricing and reporting requirements.

The Government has from time to time made policy pronouncements on FDI through press notes and press releases. The Department for Promotion of Industry and Internal Trade (formerly Department of Industrial Policy and Promotion), Ministry of Commerce and Industry, GoI, issued the consolidated FDI Policy by way of circular under DPIIT file number 5(2)/2020-FDI Policy, with effect from October 15, 2020, which consolidates and supersedes all previous press notes, press releases and clarifications on FDI issued by the DIPP that were in force and effect. The Government proposes to update the consolidated circular on FDI Policy once every year and therefore, the FDI Policy will be valid until the DIPP issues an updated circular.

Subject to certain condition, the transfer of shares by way of sale between an Indian resident and a non-resident does not require the prior approval of the RBI or the relevant ministry or department of the Government of India, provided that (i) the activities of the investee company are under the automatic route under the FDI Policy and transfer does not attract the provisions of the Takeover Regulations; (ii) the non-resident shareholding is within the sectoral limits under the Consolidated FDI Policy; and (iii) the pricing is in accordance with the guidelines prescribed by SEBI and RBI.

Further, in accordance with Press Note No. 3 (2020 Series), dated April 17, 2020 issued by the DPIIT, all investments by entities incorporated in a country which shares land border with India or where the beneficial owner of an investment into India is situated in or is a citizen of any such country (“**Restricted Investors**”), will require prior approval of the Government of India, as prescribed in the Consolidated FDI Policy. It is not clear from the press note whether or not an issuance of the Equity Shares to Restricted Investors will also require a prior approval of the Government of India and each Bidder should seek independent legal advice about its ability to participate in the Offer. In the event such prior approval of the Government of India is required and such approval has been obtained, the Bidder was required to intimate the Company and the Registrar about such approval within the Offer Period.

As per the existing policy of the Government, OCBs cannot participate in this Offer.

**The above information is given for the benefit of the Bidders. Our Company, the Selling Shareholders and the BRLMs are not liable for any amendments or modification or changes in applicable laws or regulations, which may occur after the date of this Red Herring Prospectus. Bidders are advised to make their independent investigations and ensure that the number of Equity Shares Bid for do not exceed the applicable limits under laws or regulations.**

**The Equity Shares offered in the Offer have not been and will not be registered under the U.S. Securities Act or any state securities laws in the United States, and unless so registered, may not be offered or sold within the United States, except pursuant to an exemption from, or in a transaction not subject to, the registration requirements of the U.S. Securities Act and in accordance with any applicable U.S. state securities laws. Accordingly, the Equity Shares are being offered and sold outside the United States in ‘offshore transactions’ as defined in, and in reliance on, Regulation S under the U.S. Securities Act and the applicable laws of the jurisdictions where such offers and sales are made.**

## SECTION VIII – MAIN PROVISIONS OF ARTICLES OF ASSOCIATION

*Capitalised terms used in this section have the meaning that has been given to such terms in the Articles of Association of our Company. Pursuant to Schedule I of the Companies Act, 2013 and the SEBI ICDR Regulations, the main provisions of the Articles of Association of our Company are detailed below.*

*The Articles of Association of the Company comprise two parts, Part A and Part B. In case of inconsistency or conflict between Part A and Part B, the provisions of Part B shall be applicable; however, Part B shall stand deleted, not have any force and be deemed to be removed from the Articles of Association upon the allotment of equity shares of the Company to the allottees pursuant to an initial public offering of the equity shares of the Company, without any further corporate or other action by the Company or its shareholders.*

### PART A OF THE ARTICLES OF ASSOCIATION

#### Applicability of Table F

Subject as hereinafter provided and in so far as these presents do not modify or exclude them, the regulations contained in Table 'F' of Schedule I of the Companies Act, 2013 shall apply to the Company only so far as they are not inconsistent with any of the provisions contained in these Articles or modification thereof or are not expressly or by implication excluded from these Articles.

The regulations for the management of the Company and for the observance by the members thereto and their representatives, shall, subject to any exercise of the statutory powers of the Company with reference to the deletion or alteration of or addition to its regulations by resolution as prescribed or permitted by the Companies Act, 2013, as amended from time to time, be such as are contained in these Articles.

#### Definitions and Interpretation

1. In these regulations:-

(i) Unless the context otherwise requires, words or expressions contained in these Articles shall bear the same meaning as in the Act or any statutory modifications thereof in force at the date on which the Articles become binding on the Company. In these Articles:

“**Act**” means Companies Act, 2013, and any amendments, re-enactments or other statutory modifications thereof for the time being in force and the term shall be deemed to refer to the applicable section thereof which is relatable to the relevant Article in which the said term appears in these Articles and any previous company law, so far as may be applicable.

“**Articles**” or “**Articles of Association**” means the articles of association of the Company as amended from time to time.

“**Alternate Director**” shall have the meaning ascribed to it in Article 122 of these Articles.

“**Board**” or “**Board of Directors**” means the Board of Directors of the Company as constituted from time to time in accordance with the terms of these Articles.

“**Company**” means Tega Industries Limited, a company incorporated under the laws of India.

“**Depositories Act**” means the Depositories Act, 1996 or any statutory modification or re-enactment thereof for the time being in force.

“**Depository**” means a Depository as defined under clause (e) of sub-Section (1) of Section 2 of the Depositories Act and includes a company registered under the Act, which has been granted a Certificate of Registration under sub section 1(A) of section 12 of the Securities and Exchange Board of India Act, 1992.

“**Director**” means a director of the Board, including Alternate Directors and Independent Directors appointed from time to time in accordance with the terms of these Articles and the provisions of the Act.

“**Equity Share Capital**” means in relation to the Company, its equity share capital within the meaning of Section 43 of the Act, as amended from time to time.

“**Equity Shares**” means the issued, subscribed and fully paid-up equity shares of the Company of Rs. 10/- (Rupees ten only) each.

“**General Meeting**” means any duly convened meeting of the Shareholders of the Company and includes an extraordinary general meeting.

“**Independent Director**” shall have the meaning assigned to the said term under the Act and the SEBI (Listing Obligations and Disclosure Requirements) Regulations, 2015.

“**INR**” or “**Rs.**” or “**₹**” means the Indian Rupee, the currency and legal tender of the Republic of India.

“**Law**” includes all Indian statutes, enactments, acts of legislature or parliament, laws, ordinances, rules, bye-laws, regulations, notifications, guidelines, policies, directions, determinations, directives, writs, decrees, injunctions, judgments, rulings, awards, clarifications and other delegated legislations and orders of any governmental authority (including but not limited to the Reserve Bank of India Act, 1934 and any applicable rules, regulations and directives of the Reserve Bank of India), statutory authority, tribunal, board, court, stock exchange or other judicial or quasi-judicial adjudicating authority and, if applicable, foreign law, international treaties, protocols and regulations.

“**Member**” means a member of the Company within the meaning of sub-Section 55 of Section 2 of the Act, as amended from time to time.

“**Original Director**” shall have the meaning ascribed to it in Article 122 of these Articles.

“**Person**” means any individual, sole proprietorship, unincorporated association, unincorporated organization, body corporate, corporation, partnership, unlimited or limited liability company, joint venture, governmental authority, Hindu undivided family, trust, union, organization or any other entity that may be treated as a person under applicable Law.

“**Preference Share Capital**” means in relation to the Company, its preference share capital within the meaning of Section 43 of the Act, as amended from time to time.

“**Seal**” means the common seal of the Company.

“**Shares**” means a share in the Share Capital of the Company.

“**Share Capital**” means the Equity Share Capital and Preference Share Capital of any face value together with all rights, differential rights, obligations, title, interest and claim in such shares and includes all subsequent issue of such shares of whatever face value or description, bonus shares, conversion shares and shares issued pursuant to a stock split or the exercise of any warrant, option or other convertible security of the Company.

“**Shareholder**” means a Member of the Company.

- (i) The terms “*writing*” or “*written*” include printing, typewriting, lithography, photography and any other mode or modes (including electronic mode) of representing or reproducing words in a legible and non-transitory form.
- (ii) The headings hereto shall not affect the construction hereof.
- (iii) Words importing the singular shall include the plural and vice versa;
- (iv) Any reference to a particular statute or provisions of the statute shall be construed to include reference to any rules, regulations or other subordinate legislation made under the statute and shall, unless the context otherwise requires, include any statutory amendment, modification or re-enactment thereof.
- (v) the expressions “hereof”, “herein” and similar expressions shall be construed as references to these Articles as a whole and not limited to the particular Article in which the relevant expression appears;
- (vi) any reference to a “person” includes any individual, firm, corporation, partnership, company, trust, association, joint venture, government (or agency or political subdivision thereof) or other entity of any kind, whether or not having separate legal personality. A reference to any person in these Articles shall, where the context permits, include such person’s executors, administrators, heirs, legal representatives and permitted successors and assigns;

Any reference to an agreement or other document shall be construed to mean a reference to the agreement or other document, as amended or novated from time to time.

### **Share capital and variation of rights**

The authorized Share Capital of the Company shall be as per Clause V of the Memorandum of Association of the Company.

2. Subject to the provisions of the Act and these Articles, the Shares for the time being shall be under the control of the Board, which may issue, allot or otherwise dispose of the Shares or any of them to such persons, in such proportion, on such terms and conditions, either at a premium or at par or at a discount (subject to compliance with the provisions of the Act), at such time as it may from time to time deem fit, and with the sanction of the Company in a General Meeting, to give to any person or persons the option or right to call for any Shares, either at par or premium during such time and for such consideration as the Board deems fit, and may issue and allot Shares on payment in full or part of any property sold and transferred or for any services rendered to the Company in the conduct of its business. Any Shares so allotted may be issued as fully paid-up Shares and if so issued, shall be deemed to be fully paid-up Shares. Notwithstanding the foregoing, the option or right to call for Shares shall not be given to any person or persons without the sanction of the Company in a General Meeting.
3. Subject to these Articles and the provisions of the Act, the Company may, from time to time, increase the Share Capital by such sum, to be divided into Shares of such amount, as may be specified in the resolution.
4. Subject to the provisions of the Act, the Company may from time to time, undertake any of the following:
  - (i) increase, reduce or otherwise alter its authorised Share Capital in such manner as it thinks expedient;
  - (ii) consolidate and divide all or any of its Share Capital into Shares of larger amount than its existing Shares;
  - (iii) convert all or any of its fully paid-up Shares into stock, and reconvert that stock into fully paid-up Shares of any denomination;
  - (iv) sub-divide its Shares, or any of them, into Shares of smaller amount, such that the proportion between the amount paid and the amount, if any, unpaid on each reduced Share shall be the same as it was in case of the Share from which the reduced Share is derived; or
  - (v) cancel any Shares which, at the date of the passing of the resolution in that behalf, have not been taken or agreed to be taken by any Person, and diminish the amount of its Share Capital by the amount of Shares so cancelled. A cancellation of Shares pursuant to this Article shall not be deemed to be a reduction of the Share Capital within the meaning of the Act.
5. Subject to the provisions of these Articles, the Act, other applicable Law and subject to such other approvals, permissions or sanctions as may be necessary, the Company may issue any Shares with or without differential rights upon such terms and conditions and with such rights and privileges (including with regard to voting rights and dividend) as may be permitted by the Act or the applicable Law or guidelines issued by the statutory authorities and/or listing requirements and that the provisions of these Articles.
6. Subject to the provisions of the Act, any preference shares may be issued on the terms that they are, or at the option of the Company are, liable to be redeemed on such terms and in such manner as the Company before the issue of the preference shares may, in accordance with the provisions of the Act.
7. The period of redemption of such preference shares shall not exceed the maximum period for redemption provided under the Act.
8. Subject to Law, where at any time, it is proposed to increase its subscribed capital by the issue/allotment of further Shares either out of the unissued capital or increased Share Capital then, such further Shares may be offered to:
  - (i) Persons who, at the date of offer, are holders of Shares of the Company, in proportion, as nearly as circumstances admit, to the capital paid up on those Shares by sending a letter of offer subject to the

following conditions: (a) the offer shall be made by notice specifying the number of Shares offered and limiting a time not being less than 15 (fifteen) days or such lesser number of days as may be prescribed under the Act and not exceeding 30 (thirty) days from the date of the offer within which the offer, if not accepted, will be deemed to have been declined; (b) the offer aforesaid shall be deemed to include a right exercisable by the Person concerned to renounce the Shares offered to him or any of them in favour of any other Person and the notice referred to in (i) shall contain a statement of this right, provided that the Board may decline, without assigning any reason therefore, to allot any Shares to any Person in whose favor any Member may renounce the Shares offered to him; and (c) after expiry of the time specified in the notice aforesaid, or on receipt of earlier intimation from the Person to whom such notice is given that he declines to accept the Shares offered, the Board may dispose of them in such manner which is not disadvantageous to the Members and the Company;

Nothing in sub-Article (i) (b) above shall be deemed to extend the time within which the offer should be accepted; or to authorize any Person to exercise the right of renunciation for a second time on the ground that the Person in whose favour the renunciation was first made has declined to take the Shares comprised in the renunciation.

- (ii) employees under a scheme of employees' stock option, subject to special resolution passed by the Company and subject to such conditions as may be prescribed under the Act and other applicable Laws; or
  - (iii) any Persons, if authorised by a special resolution, whether or not those Persons include the Persons referred to in (i) or (ii) above, either for cash or for a consideration other than cash, subject to applicable Laws.
9. Nothing in Article 9 above shall apply to the increase of the subscribed capital of the Company caused by the exercise of an option as a term attached to the debentures issued or loan raised by the Company to convert such debentures or loans into Shares in the Company or to subscribe for Shares in the Company. Provide that the terms of the issue of such debentures or the terms of such loans include a term providing for such option and such term:
- (i) Either has been approved by the Central Government before the issue of debentures or the raising of the loans or is in conformity with the Rules, if any made by that Government in this behalf; and
  - (ii) In the case of debentures or loans or other than debentures issued to, or loans obtained from the Government or any institution specified by the Central Government in this behalf, has also been approved by the Special Resolution passed by the Company in General Meeting before the issue of the loans.
10. Save as otherwise provided in the Articles, the Company shall be entitled to treat the registered holder of any Share as the absolute owner thereof and accordingly shall not, except as ordered by a Court of competent jurisdiction, or as by Law required, be bound to recognize any equitable or other claim to or interest in such Shares on the part of any other Person.
11. Except as required by Law, no Person shall be recognised by the Company as holding any Share upon any trust, and the Company shall not be bound by, or be compelled in any way to recognise (even when having notice thereof) any equitable, contingent, future or partial interest in any Share, or any interest in any fractional part of a Share, or (except only as by these Articles or by Law otherwise provided) any other rights in respect of any Share except an absolute right to the entirety thereof in the registered holder.
12. If at any time the Share Capital is divided into different classes of Shares, the rights attached to any class (unless otherwise provided by the terms of issue of the Shares of that class) may, subject to the provisions of the Act, and whether or not the Company is being wound up, be varied with the consent in writing of the holders of three-fourths of the issued Shares of that class, or with the sanction of a special resolution passed at a separate meeting of the holders of the Shares of that class. To every such separate general meeting of the holders of the Shares of that class, the provisions of these Articles relating to General Meetings shall *mutatis mutandis* apply, but so that the necessary quorum shall be at least two persons holding at least one-third of the issued Shares of the class in question.
13. The rights conferred upon the holders of the Shares of any class issued with preferred or other rights shall not, unless otherwise expressly provided by the terms of issue of the Shares of that class, be deemed to be varied by the creation or issue of further Shares ranking *pari passu* therewith.



14. Subject to the provisions of the Act, the Company may issue bonus Shares to its Members out of (i) its free reserves; (ii) the securities premium account; or (iii) the capital redemption reserve account, in any manner as the Board may deem fit.
15. Subject to the provisions of Sections 68 to 70 and other applicable provisions of the Act or any other Law for the time being in force, the Company shall have the power to buy-back its own Shares or other securities, as it may consider necessary.
16. Subject to the provisions of the Act, the Company shall have the power to make compromise or make arrangements with creditors and Members, consolidate, demerge, amalgamate or merge with other company or companies in accordance with the provisions of the Act and any other applicable Laws.
17. Subject to the provisions of the Act, the Company may, from time to time, by special resolution reduce in any manner and with, and subject to, any incident authorised and consent required under applicable Law:
  - (i) the Share Capital;
  - (ii) any capital redemption reserve account; or
  - (iii) any securities premium account.

#### **Lien**

18. The Company shall have a first and paramount lien upon all the Shares/ debentures (other than fully paid up Shares/debentures) registered in the name of each Member (whether solely or jointly with others), and upon the proceeds of sale thereof for all moneys (whether presently payable or not) called or payable at a fixed time in respect of such Shares/debentures and no equitable interest in any Share shall be created except upon the footing and condition that this Article will have full effect. Such lien shall extend to all dividends and bonuses from time to time declared in respect of such Shares/debentures. Fully paid up Shares shall be free from all liens. Unless otherwise agreed, the registration of a transfer of Shares/debentures shall operate as a waiver of the Company's lien if any, on such Shares/debentures. The Board may at any time declare any Shares/debentures wholly or in part to be exempt from the provisions of this Article.
19. Subject to the provisions of the Act, the Company may sell, in such manner as the Board thinks fit, any Shares on which the Company has a lien.
20. A Member shall not exercise any voting rights in respect of the Shares in regard to which the Company has exercised the right of lien.
21. The Company may sell, in such manner as the Board thinks fit, any shares on which the Company has a lien:

Provided that no sale shall be made—

- a) unless a sum in respect of which the lien exists is presently payable; or
  - b) until the expiration of 14 (fourteen) days after a notice in writing stating and demanding payment of such part of the amount in respect of which the lien exists as is presently payable, has been given to the registered holder for the time being of the share or the person entitled thereto by reason of his death or insolvency.
22. To give effect to any such sale, the Board may authorise some person to transfer the Shares sold to the purchaser thereof. The purchaser shall be registered as the holder of the Shares comprised in any such transfer. The purchaser shall not be bound to see to the application of the purchase money, nor shall his title to the Shares be affected by any irregularity or invalidity in the proceedings in reference to the sale.
  23. The proceeds of the sale shall be received by the Company and applied in payment of such part of the amount in respect of which the lien exists as is presently payable. The residue, if any, shall, subject to a like lien for sums not presently payable as existed upon the Shares before the sale, be paid to the person entitled to the Shares at the date of the sale.

### **Calls on shares**

24. Subject to the provisions of the Act, the Board may, from time to time, make calls upon the Members in respect of any money unpaid on their Shares (whether on account of the nominal value of the Shares or by way of premium) and not by the conditions of allotment thereof made payable at fixed times.
25. Each Member shall, subject to receiving at least 14 (fourteen) days' notice specifying the time or times and place of payment, pay to the Company, at the time or times and place so specified, the amount called on his Shares.
26. A call may be revoked or postponed at the discretion of the Board.
27. A call shall be deemed to have been made at the time when the resolution of the Board authorising the call was passed and may be required to be paid by instalments.
28. The joint-holders of a Share shall be jointly and severally liable to pay all calls in respect thereof.
29. If a sum called in respect of a Share is not paid before or on the day appointed for payment thereof, the Person from whom the sum is due shall pay interest thereof from the day appointed for payment thereof to the time of actual payment at 10% (ten per cent) per annum or at such lower rate, if any, as the Board may determine. The Board shall be at liberty to waive payment of any such interest wholly or in part.
30. Any sum which by the terms of the issue of a Share becomes payable on allotment or at any fixed date, whether on account of the nominal value of the Share or by way of premium, shall, for the purposes of these Articles, be deemed to be a call duly made and payable on the date on which by the terms of issue, such sum becomes payable. In case of non-payment of such sum, all the relevant provisions of these Articles as to payment of interest and expenses, forfeiture or otherwise shall apply as if such sum had become payable by virtue of a call duly made and notified.
31. The Board may, if it thinks fit, subject to the provisions of the Act, agree to and receive from any Member willing to advance the same, whole or any part of the moneys due upon the Shares held by him beyond the sums actually called for and upon the amount so paid or satisfied in advance, or so much thereof as from time to time exceeds the amount of the calls then made upon the Shares in respect of which such advance has been made, the Company may pay interest at such rate as determined by the Board and the Member paying such sum in advance agree upon, provided that money paid in advance of calls shall not confer a right to participate in profits or dividend. The Board may at any time repay the amount so advanced.

The Member shall not be entitled to any voting rights in respect of the moneys so paid by him until the same would, but for such payment, become presently payable.

The provisions of these Articles shall *mutatis mutandis* apply to any calls on debentures of the Company.

### **Transfer of shares**

32. The securities or other interest of any Member shall be freely transferable, provided that any contract or arrangement between 2 (two) or more Persons in respect of transfer of securities shall be enforceable as a contract. The instrument of transfer of any Share of the Company shall be duly executed by or on behalf of both the transferor and transferee. The transferor shall be deemed to remain a holder of the Share until the name of the transferee is entered in the register of Members in respect thereof. A common form of transfer shall be used in case of transfer of Shares. The instrument of transfer shall be in writing and all the provisions of Section 56 of the Act and of any statutory modification thereof for the time being shall be duly complied with in respect of all transfers of Shares and the registration thereof.
33. Subject to the provisions of the Act, these Articles, any listing agreement entered into with any recognized stock exchange and any other applicable Law for the time being in force, the Board may, at their own absolute and uncontrolled discretion and by giving reasons, decline to register or acknowledge any transfer of Shares, whether fully paid or not, or any interest of a Member. The Board shall within 1 (one) month from the date on which the instrument of transfer or the intimation of such transmission was lodged with the Company, send to the transferee and transferor or to the person giving intimation of such transmission, as the case may be, notice of the refusal to register such transfer. Provided that registration of a transfer shall not be refused on the ground of the transferor being either alone or jointly with any

other person or persons indebted to the Company on any account whatsoever, except where the Company has a lien on the Shares or other Securities, provided however, that the Board may decline to register or acknowledge any transfer, whether fully paid-up or not, if the transfer results in, or is perceived to or may result in, a contravention or violation of any foreign investment limit or restriction under applicable Law as applicable to the Company, and further, that the decision of the Board or any persons designated by the Board with respect to whether the transfer results in, or is perceived to or may result in, a contravention or violation of any foreign investment limit or restriction under Applicable Law as applicable to the Company shall be final and binding in all respects. Transfer of Shares/debentures in whatever lot shall not be refused.

34. Save as otherwise provided in the Act or any applicable Law, no transfer of a Share shall be registered unless a proper instrument of transfer duly stamped and executed by or on behalf of the transferor and by or on behalf of the transferee has been delivered to the Company together with the certificate or certificates of Shares, and if no such certificate is in existence, then the letter of allotment of the Shares or such other evidence as the Board may reasonably require to show the right of the transferor to make the transfer. Application for the registration of the transfer of a Share may be made either by the transferor or by the transferee provided that where such application is made by the transferor, no registration shall, in the case of a partly paid Share be affected unless the Company gives notice of the application to the transferee in the manner prescribed under the Act, and subject to the provisions of these Articles, the Company shall, unless objection is made by the transferee, within 2 (two) weeks from the date of receipt of the notice, enter in the register the name of the transferee in the same manner and subject to the same conditions as if the application for registration of the transfer was made by the transferee. On giving not less than 7 (seven) days previous notice in accordance with the Act or any other time period as may be specified by Law, the registration of transfers may be suspended at such times and for such periods as the Board may from time to time determine, provided that such registration shall not be suspended for more than 30 (thirty) days at any one time or for more than 45 (forty five) days in the aggregate in any year.
35. No fee shall be charged for registration of transfer, transmission, probate, succession certificate and letters of administration, certificate of death or marriage, power of attorney or similar other documents.

#### **Transmission of shares**

36. On the death of a Member, the survivor or survivors where the Member was a joint holder of the Shares, and his nominee or nominees or legal representatives where he was a sole holder, shall be the only Person(s) recognised by the Company as having any title to his interest in the Shares. Nothing in these Articles shall release the estate of the deceased joint holder from any liability in respect of any Share which had been jointly held by him with other Persons.
37. Any Person becoming entitled to a Share in consequence of the death or insolvency of a Member may, upon such evidence being produced as the Board may from time to time require, and subject as hereinafter provided, elect, either:
- (i) to be registered as holder of the Share; or
  - (ii) to make such transfer of the Share as the deceased or insolvent Member could have made.
38. The Board shall, in either case, have the same right to decline or suspend registration as it would have had, if the deceased or insolvent Member had transferred the Share before his death or insolvency.
39. If the Person so becoming entitled shall elect to be registered as holder of the Shares, such person shall deliver or send to the Company a notice in writing signed by him stating that he so elects.
40. If the Person aforesaid shall elect to transfer the Share, he shall testify his election by executing an instrument of transfer in accordance with the provisions of these Articles relating to transfer of Shares.
41. All the limitations, restrictions and provisions contained in these Articles relating to the right to transfer and the registration of transfers of Shares shall be applicable to any such notice or transfer as aforesaid as if the death or insolvency of the Member had not occurred and the notice or transfer were a transfer signed by that Member.

42. A Person becoming entitled to a Share by reason of the death or insolvency of the holder shall be entitled to the same dividends and other advantages to which he would be entitled if he were the registered holder of the Share, except that he shall not, before being registered as a Member in respect of the Share, be entitled in respect of it to exercise any right conferred by membership in relation to the General Meetings of the Company, *provided that* the Board may, at any time, give notice requiring any such Person to elect either to be registered himself or to transfer the Share, and if the notice is not complied with within 90 (ninety) days, the Board may thereafter withhold payment of all dividends, bonuses or other moneys payable in respect of the Share, until the requirements of the notice have been complied with. Article 54 provides that “On the death of a Member, the survivor or survivors where the Member was a joint holder of the Shares, and his nominee or nominees or legal representatives where he was a sole holder, shall be the only Person(s) recognised by the Company as having any title to his interest in the Shares. Nothing in these Articles shall release the estate of the deceased joint holder from any liability in respect of any Share which had been jointly held by him with other Persons.”

### **Shareholders’ meetings**

43. An annual General Meeting shall be held each year within the period specified by the Law. Not more than 15 (fifteen) months shall elapse between the date of one annual General Meeting of the Company and that of the next. Nothing contained in the foregoing provisions shall be taken as affecting the right conferred upon the Registrar under the provisions of Section 96 of the Act to extend the time within which any annual General Meeting may be held. Every annual General Meeting shall be called during business hours on a day that is not a national holiday, and shall be held either at the registered office or at some other place within the city in which the registered office of the Company is situate, as the Board may determine.
44. All General Meetings other than the annual General Meeting shall be called extraordinary General Meetings.
45. (i) The Board may, whenever it thinks fit, call an extraordinary General Meeting.
- (ii) The Board shall on the requisition of such number of Member or Members of the Company as is specified in Section 100 of the Act, forthwith proceed to call an extra-ordinary General Meeting of the Company and in respect of any such requisition and for any meeting to be called pursuant thereto, all other provisions of Section 100 of the Act shall for the time being apply.
- (iii) A General Meeting of the Company may be convened by giving not less than clear 21 (twenty-one) days’ notice either in writing or through electronic mode in such manner as prescribed under the Act, *provided that* a General Meeting may be called after giving a shorter notice as per the Act.
- (iv) Notice of every General Meeting shall be given to the Members and to such other Person or Persons as required by and in accordance with Section 101 and 102 of the Act and it shall be served in the manner authorized by Section 20 of the Act.
- (v) If at any time Directors capable of acting who are sufficient in number to form a quorum are not within India, any Director or any 2 (two) Members of the Company may call an Extraordinary General Meeting in the same manner, as nearly as possible, as that in which such a meeting may be called by the Board.

### **Proceedings at general meetings**

46. No business shall be transacted at any General Meeting, unless a quorum of Members is present at the time when the meeting proceeds to transact business.
47. Save as otherwise provided herein, the quorum for the General Meetings shall be as provided in Section 103 of the Act.
48. In the event a quorum as required herein is not present within 30 (thirty) minutes of the appointed time, then subject to the provisions of Section 103 of the Act, the General Meeting shall stand adjourned to the same place and time 7 (seven) days later or to such other date and such other time and place as the Board may determine, provided that the agenda for such adjourned General Meeting shall remain the same. The said General Meeting if called by requisitionists under Section 100 of the Act shall stand cancelled.

49. In case of an adjourned meeting or of a change of day, time or place of meeting, the Company shall give not less than 3 (three) days' notice to the Members either individually or by publishing an advertisement in the newspapers (one in English and one in vernacular language) which is in circulation at the place where the registered office of the Company is situated.
50. The required quorum at any adjourned General Meeting shall be the same as that required at the original General Meeting.
51. If at the adjourned meeting too a quorum is not present within 30 (thirty) minutes from the time appointed for holding such meeting, the Members present shall be the quorum and may transact the business for which the meeting was called.
52. The Chairman may, with the consent of Members at any meeting at which a quorum is present, and shall, if so directed at the meeting, adjourn the meeting, from time to time and from place to place.
53. No business shall be transacted at any adjourned General Meeting other than the business left unfinished at the meeting from which the adjournment took place.
54. When a meeting is adjourned for 30 (thirty) days or more, notice of the adjourned meeting shall be given as in the case of an original meeting.
55. Save as aforesaid, and as provided in Section 103 of the Act, it shall not be necessary to give any notice of an adjournment or of the business to be transacted at an adjourned meeting.
56. Notwithstanding anything contained elsewhere in these Articles, the Company:
- (i) shall, in respect of such items of business as the Central Government may, by notification, declare or which are under any other applicable Law required to be transacted only by means of postal ballot; and
  - (ii) may, in respect of any item of business, other than ordinary business and any business in respect of which Directors or auditors have a right to be heard at any meeting, transact by means of postal ballot,
- in such manner as may be prescribed, instead of transacting such business at a General Meeting and any resolution approved by the requisite majority of the Members by means of such postal ballot, shall be deemed to have been duly passed at a General Meeting convened in that behalf and shall have effect accordingly.

Provided that any item of business required to be transacted by means of postal ballot under Article 93(i), may be transacted at a General Meeting by Company, in the manner provided in Section 108 of the Act.

57. Directors may attend and speak at General Meetings, whether or not they are Shareholders.
58. A body corporate being a Member shall be deemed to be personally present if it is represented in accordance with Section 113 of the Act.
59. The Chairman, if any, of the Board shall preside as Chairman at every General Meeting of the Company.
60. If there is no such Chairman or if he is not present within 15 (fifteen) minutes after the time appointed for holding the General Meeting or is unwilling to act as the Chairman of the General Meeting, the Directors present shall elect one of their members to be the Chairman of the General Meeting.
61. If at any General Meeting no Director is willing to act as the Chairman or if no Director is present within 15 (fifteen) minutes after the time appointed for holding the General Meeting, the Members present shall choose one of their Members to be the Chairman of the General Meeting.

### **Directors**

62. Subject to the provisions of the Act, the number of Directors shall not be less than 3 (three) and more than 15 (fifteen), provided that the Company may appoint more than 15 (fifteen) directors after passing a special resolution. At least one Director shall reside in India for a total period of not less than 182 (one hundred and eighty-two) days in each financial year.
63. The following were the first Directors of the Company:

- a) Dr. D.P. Antia;
  - b) Mr. F.R. Bhesania; and
  - c) Mr. Madan Mohan Mohanka
64. The remuneration of the Directors shall, in so far as it consists of a monthly payment, be deemed to accrue from day-to-day.
65. In addition to the remuneration payable to them in pursuance of the Act, the Directors may be paid all travelling, hotel and other expenses properly incurred by them:
- (a) in attending and returning from meetings of the Board or any committee thereof or General Meetings of the Company; or
  - (b) in connection with the business of the Company.
66. All cheques, promissory notes, drafts, hundis, bills of exchange and other negotiable instruments, and all receipts for monies paid to the Company, shall be signed, drawn, accepted, endorsed, or otherwise executed, as the case may be, by such person and in such manner as the Board shall from time to time by resolution determine.
67. Every Director present at any meeting of the Board or of a committee thereof shall sign his name in a book to be kept for that purpose.
68. (i) Subject to the provisions of Section 161 of the Act, the Board shall have power at any time, and from time to time, to appoint a person as an additional Director, provided the number of the Directors and additional Directors together shall not at any time exceed the maximum strength fixed for the Board by these Articles.
- (ii) Such person shall hold office only up to the date of the next annual General Meeting of the Company but shall be eligible for appointment by the Company as a Director at that meeting subject to the provisions of the Act.
69. Subject to the provisions of the Act, the Board shall have the power to determine the Directors whose period of office is or is not liable to determination by retirement of directors by rotation. Any Director duly appointed by the Company for a fixed term (including the Independent Directors and the Managing Director) shall not be liable to retire by rotation.
70. Subject to the provisions of the Act, each Director shall be paid sitting fees for each meeting of the Board or a Committee thereof attended by him, subject to the ceiling prescribed under the Act.
71. The Directors shall also be paid travelling and other expenses for attending and returning from meeting of the Board of Directors (including hotel expenses) and any other expenses properly incurred by them in connection with the business of the Company. The Directors may also be remunerated for any extra services done by them outside their ordinary duties as Directors, subject to the provisions of Section 197 of the Act.
72. In the event that a Director is absent for a continuous period of not less than 3 (three) months from India (an “**Original Director**”), subject to these Articles, the Board may appoint another Director (an “**Alternate Director**”), not being a person holding any alternate directorship for any other Director or holding directorship in the Company, for and in place of the Original Director. The Alternate Director shall be entitled to receive notice of all meetings and to attend and vote at such meetings in place of the Original Director and generally to perform all functions of the Original Director in the Original Director’s absence. No Person shall be appointed as an Alternate Director to an Independent Director unless such Person is qualified to be appointed as an Independent Director of the Company. Any Person so appointed as Alternate Director shall not hold office for a period longer than that permissible to the Original Director and shall vacate the office if and when the Original Director returns to India.
73. The office of a Director shall automatically become vacant, if he is disqualified under any of the provisions of the Act. Further, subject to the provisions of the Act, a Director may resign from his office at any time by giving a notice in writing to the Company and the Board shall on receipt of such notice

take note of the same and the Company shall intimate the Registrar and also place the fact of such resignation in the report of Directors laid in the immediately following General Meeting. Such Director may also forward a copy of his resignation along with detailed reasons for the resignation to the Registrar within 30 (thirty) days of resignation. The resignation of a Director shall take effect from the date on which the notice is received by the Company or the date, if any, specified by the Director in the notice, whichever is later.

74. At any annual General Meeting at which a Director retires, the Company may fill up the vacancy by appointing the retiring Director who is eligible for re-election or some other Person if a notice for the said purpose has been left at the office of the Company in accordance with the provisions of the Act.
75. No Person shall be appointed as a Director unless he furnishes to the Company his Director Identification Number under Section 154 of the Act or any other number as may be prescribed under Section 153 of the Act and a declaration that he is not disqualified to become a Director under the Act.
76. No Person appointed as a Director shall act as a Director unless he gives his consent to hold the office as a Director and such consent has been filed with the Registrar within 30 (thirty) days of his appointment in the manner prescribed in the Act.
77. Subject to the provisions of the Act, the Directors shall have the power, at any time and from time to time to appoint any Persons as Additional Director in addition to the existing Directors so that the total number of Directors shall not at any time exceed the number fixed for Directors in these Articles. Any Director so appointed shall hold office only until the next following annual General Meeting or the last date on which the annual General Meeting should have been held, whichever is earlier, but shall be eligible for re-appointment as Director.
78. The Company, may by ordinary resolution, of which special notice has been given in accordance with the Section 169 of the Act, remove any Director including the managing director, if any, before the expiration of the period of his office. Notwithstanding anything contained in these regulations or in any agreement between the Company and such Director, such removal shall be without prejudice to any contract of service between him and the Company.
79. If the office of any Director appointed by the Company in a General Meeting, is vacated before his term of office expires in the normal course, the resulting casual vacancy may be filled up by the Board at a meeting of the Board but any Person so appointed shall retain his office so long only as the vacating Director would have retained the same if such vacancy had not occurred.
80. In the event of the Company borrowing any money from any financial corporation or institution or government or any government body or a collaborator, bank, Person or Persons or from any other source, while any money remains due to them or any of them the lender concerned may have and may exercise the right and power to appoint, from time to time, any Person or Persons to be a Director or Directors of the Company and the Directors so appointed, shall not be liable to retire by rotation, subject however, to the limits prescribed by the Act. Any Person so appointed may at any time be removed from the office by the appointing authority who may from the time of such removal or in case of death or resignation of Person, appoint any other or others in his place. Any such appointment or removal shall be in writing, signed by the appointee and served on the Company. Such Director need not hold any qualification Shares.
81. The Company may take and maintain any insurance as the Board may think fit on behalf of its present and/or former Directors and key managerial personnel for indemnifying all or any of them against any liability for any acts in relation to the Company for which they may be liable but have acted honestly or reasonably.

#### **Managing director or whole time director**

82. The Board may, from time to time, subject to Section 196 and other applicable provisions of the Act, appoint one or more of their body to the office of the managing director or whole time Director for such period and on such remuneration and other terms, as they think fit and subject to the terms of any agreement entered into in any particular case, may revoke such appointment.

83. Subject to the provisions of any contract between him and the Company, the managing director/ whole-time director, shall be subject to the same provisions as to resignation and removal as the other Directors and his appointment shall automatically terminate if he ceases to be a Director.
84. Subject to the provisions of the Act, a managing director or whole time director may be paid such remuneration (whether by way of salary, commission or participation in profits or partly in one way and party in other) as the Board may determine.
85. The Board, subject to Section 179 and any other applicable provisions of the Act, may entrust to and confer upon a managing director or whole time director any of the powers exercisable by them upon such terms and conditions and with such restrictions, as they may think fit and either collaterally with or to the exclusion of their own powers and may, from time to time, revoke, withdraw or alter or vary all or any of such powers.

#### **Meetings of the board**

86. The Board may meet for the conduct of business, adjourn and otherwise regulate its meetings, as it thinks fit.
87. A Director may, and the manager or secretary upon the requisition of a Director shall, at any time convene a meeting of the Board.
88. Subject to the provisions the Act, the Board shall meet at least 4 (four) times in a year in such a manner that not more than 120 (one hundred and twenty) days shall intervene between 2 (two) consecutive meetings of the Board.
89. The quorum for the meeting of the Board shall be one third of its total strength or 2 (two) directors, whichever is higher, and the participation of the directors by video conferencing or by other audio visual means shall also be counted for the purpose of quorum.
90. The continuing Directors may act notwithstanding any vacancy in the Board; but if and so long as their number is reduced below the quorum fixed by the Act for a meeting of the Board, the continuing Directors or Director may act for the purpose of increasing the number of Directors to that fixed for the quorum, or of summoning a General Meeting of the Company, but for no other purpose.
91. If quorum is found to be not present within 30 (thirty) minutes from the time when the meeting should have begun or if during the meeting, valid quorum no longer exists, the meeting shall be reconvened at the same time and at the same place 7 (seven) days later. At the reconvened meeting, the Directors present and not being less than 2 (two) Persons shall constitute the quorum and may transact the business for which the meeting was called and any resolution duly passed at such meeting shall be valid and binding on the Company.
92. Subject to the provisions of the Act allowing for shorter notice periods, a meeting of the Board shall be convened by giving not less than 7 (seven) days' notice in writing to every Director at his address registered with the Company and such notice shall be sent by hand delivery or by post or by electronic means.
93. Save as otherwise expressly provided in the Act, questions arising ay any meeting of the Board shall be decided by a majority of votes.
94. The Board may elect a Chairman for its meetings and determine the period for which he is to hold office. If no such Chairman is elected, or if at any meeting the Chairman is not present within 5 (five) minutes after the time appointed for holding the meeting, the Directors present may choose one of their number to be Chairman of the meeting.
95. In case of equality of votes, the Chairman of the Board shall have a second or casting vote at Board meetings of the Company.
96. Subject to these Articles and Sections 175,179 and other applicable provisions of the Act, a circular resolution in writing, executed by or on behalf of a majority of the Directors or members of the Committee, shall constitute a valid decision of the Board or committee thereof, as the case may be, provided that a draft of such resolution together with the information required to make a fully-informed



good faith decision with respect to such resolution and appropriate documents required to evidence passage of such resolution, if any, was sent to all of the Directors or members of the committee (as the case may be) at their addresses registered with the Company in India by hand delivery or by post or by courier, or through such electronic means as may be prescribed under the Act, and has been approved by a majority of the Directors or members who are entitled to vote on the resolution.

97. All acts done in any meeting of the Board or of a committee thereof or by any Person acting as a Director shall, notwithstanding that it may be afterwards discovered that his appointment was invalid by reason of any defect for disqualification or had terminated by virtue of any provisions contained in the Act, or in these Articles, be as valid as if every such Director or such Person had been duly appointed and was qualified to be a Director.
98. Save as otherwise expressly provided in the Act, a resolution in writing, signed by all the members of the Board or of a committee thereof, for the time being entitled to receive notice of a meeting of the Board or committee, shall be valid and effective as if it had been passed at a meeting of the Board or committee, duly convened and held.
99. Subject to the provisions of the Act, no Director shall be disqualified by his office from contracting with the Company, nor shall any such contract entered into by or on behalf of the Company in which any Director shall be in any way interested be avoided, nor shall any Director contracting or being so interested be liable to account to the Company for any profit realized by any such contract by reason only of such Director holding that office or of the fiduciary relations thereby established; provided that every Director who is in any way whether directly or indirectly concerned or interested in a contract or arrangement, entered into or to be entered into by or on behalf of the Company, shall disclose the nature of his concern or interest at a meeting of the Board and shall not participate in such meeting as required under Section 184 and other applicable provisions of the Act, and his presence shall not count for the purposes of forming a quorum at the time of such discussion or vote.

#### **Powers of the board and constitution of committees of the board**

100. Subject to Section 179 of the Act, the Directors shall have the right to delegate any of their powers to such managers, agents or other Persons as they may deem fit and may at their own discretion revoke, vary or withdraw such powers.
101. The Board of Directors shall, or shall authorize Persons in their behalf, to make necessary filings with governmental authorities in accordance with the Act and other applicable Law, as may be required from time to time.
102. Subject to the provisions of the Act and these Articles, the management of affairs of the Company shall be vested in the Board who shall be entitled to exercise all such powers, and to do all such acts and things as the Company is authorized to exercise and do; provided that the Board shall not exercise any power or do any act or thing which is directed or required, whether by the Act, or any other statute or by the Memorandum of Association or by these Articles or otherwise, to be exercised or done by the Company in a General Meeting; provided further that in exercising any such power or doing any such act or thing, the Board shall be subject to the provisions in that behalf contained in the Act or any other statute or in the Memorandum of Association of the Company or in these Articles, or in any regulations not inconsistent therewith and duly made thereunder, including regulations made by the Company in a General Meeting, but no regulation made by the Company in a General Meeting shall invalidate any prior act of the Board which would have been valid if that regulation had not been made.
  - (i) The Board may, subject to the provisions of the Act, delegate any of its powers to committees consisting of such member or members of its body as it thinks fit and may determine their functions, powers, authorities and responsibilities. Such Committees will meet as frequently as the Board may decide, subject to applicable Laws.
103. Any committee so formed shall, in the exercise of the powers so delegated, conform to any regulations that may be imposed on it by the Board.
104. A committee may elect a Chairman of its meetings and may also determine the period for which he is to hold office. If no such Chairman is elected, or if at any meeting the Chairman is not present within 5

(five) minutes after the time appointed for holding the meeting, the Members present may choose one of their Members to be Chairman of the meeting.

105. A committee may meet and adjourn as it thinks fit.
106. Questions arising at any meeting of a committee shall be determined by a majority of votes of the Directors present. The chairperson of the committee, if any, shall not have any second or casting vote.

#### **Dividend and reserves**

107. The Company in a General Meeting may declare dividends, but no dividend shall exceed the amount recommended by the Board.
108. Subject to the provisions of the Act, the Board may from time to time pay to the Members such interim dividends as appear to it to be justified by the profits of the Company.
109. The Board may, before recommending any dividend, set aside out of the profits of the Company such sums as it thinks fit as a reserve or reserves which shall, at the discretion of the Board, be applicable for any purpose to which the profits of the Company may be properly applied, including provision for meeting contingencies or for equalising dividends; and pending such application, may, at the like discretion, either be employed in the business of the Company or be invested in such investments (other than shares of the Company) as the Board may, from time to time, think fit. The Board may also carry forward any profits which it may consider necessary not to divide, without setting them aside as a reserve.
110. Subject to the rights of Persons, if any, entitled to Shares with special rights as to dividends, all dividends shall be declared and paid according to the amounts paid or credited as paid on the Shares in respect whereof the dividend is paid, but if and so long as nothing is paid upon any of the Shares in the Company, dividends may be declared and paid according to the amounts of the Shares.
111. No amount paid or credited as paid on a Share in advance of calls shall be treated for the purpose of these Articles as paid on the Share.
112. All dividends shall be apportioned and paid proportionately to the amounts, paid or credited as paid on the Shares during any portion or portions of the period in respect of which the dividend is paid, but if any Share is issued on terms providing that it shall rank for dividend as from a particular date such Share shall rank for dividend accordingly.
113. The Board may deduct from any dividend payable to any Member all sums of money, if any, presently payable by him to the Company on account of calls or otherwise in relation to the Shares.
114. Any dividend, interest or other monies payable in cash in respect of Shares may be paid by electronic mode or by cheque, demand draft or warrant sent through the post directed to the registered address of the holder or, in the case of joint holders, to the registered address of that one of the joint holders who is first named on the register of Members of the Company, or to such Person and to such address as the holder or joint holders may in writing direct.
115. Every such cheque or warrant shall be made payable to the order of the Person to whom it is sent.
116. Any one of two or more joint holders of a Share may give effectual receipts for any dividends, bonuses or other payments in respect of such Share.
117. Notice of any dividend, whether interim or otherwise, that may have been declared shall be given to the Persons entitled to share therein in the manner mentioned in the Act.
118. No dividend shall bear interest against the Company.
119. No unclaimed or unpaid dividend shall be forfeited by the Board before it becomes barred by law.
120. Where the Company has declared a dividend which has not been paid or the dividend warrant in respect thereof has not been posted within 30 days from the date of declaration to any Shareholder entitled to the payment of the dividend the Company shall within such period as prescribed under applicable law, open a special account in that behalf in any scheduled bank called "Unpaid Dividend Account" and transfer to the

said account, the total amount of dividend which remains unpaid or in relation to which no dividend warrant has been posted. Any money transferred to the unpaid dividend account of the Company which remains unpaid or unclaimed for a period of seven years from the date of such transfer, shall be transferred by the Company to the fund known as the Investor Education and Protection Fund established under Section 125 of the Act. A claim to any money so transferred to the Investor Education and Protection Fund may be preferred to the Central Government by the Shareholders to whom the money is due. No unclaimed or unpaid dividend shall be forfeited by the Board before the claim becomes barred by the law.

### **Winding up**

121. Subject to the provisions of Chapter XX of the Act and rules made thereunder—

- (i) If the Company shall be wound up, the liquidator may, with the sanction of a Special Resolution of the Company and any other sanction required by the Act, divide amongst the Members, in specie or kind, the whole or any part of the assets of the Company, whether they shall consist of property of the same kind or not.
- (ii) For the purpose aforesaid, the liquidator may set such value as he deems fair upon any property to be divided as aforesaid and may determine how such division shall be carried out as between the Members or different classes of Members.

The liquidator may, with the like sanction, vest the whole or any part of such assets in trustees upon such trusts for the benefit of the contributories if he considers necessary, but so that no member shall be compelled to accept any Shares or other securities whereon there is any liability.

### **PART B OF THE ARTICLES OF ASSOCIATION**

All articles of Part B shall automatically terminate and cease to have any force and effect from the date of Allotment of Equity Shares of the Company to the Allottees pursuant to the Offer and the provisions of Part A shall continue to be in effect and be in force, without any further corporate or other action, by the Company or by its Shareholders.

## SECTION IX – OTHER INFORMATION

### MATERIAL CONTRACTS AND DOCUMENTS FOR INSPECTION

The following contracts (not being contracts entered into in the ordinary course of business carried on by our Company or entered into more than two years before the date of this Red Herring Prospectus) which are, or may be deemed material, have been entered or to be entered into by our Company. These contracts, copies of which have been attached to the copy of this Red Herring Prospectus and filed with the RoC, and are also available at the following web-link, <https://www.tegaindustries.com/tega-investors/#matcontract> from the date of this Red Herring Prospectus until the Bid/ Offer Closing Date for inspection. Copies of the documents for inspection referred to hereunder may be inspected at our Registered Office, from 10.00 am to 5.00 pm on Working Days from the date of this Red Herring Prospectus until the Bid/ Offer Closing Date.

Any of the contracts or documents mentioned in this Red Herring Prospectus may be amended or modified at any time if so required in the interest of our Company or if required by other parties, without reference to the Shareholders, subject to compliance of the provisions contained in the Companies Act and other Applicable Law.

#### *Material Contracts to the Offer*

1. Offer Agreement dated August 17, 2021 as amended by the amendment to the offer agreement dated November 10, 2021, entered into among our Company, the Selling Shareholders and the BRLMs.
2. Registrar Agreement dated August 17, 2021 entered into among our Company, the Selling Shareholders and the Registrar to the Offer.
3. Cash Escrow and Sponsor Bank Agreement dated November 23, 2021 entered into among our Company, the Selling Shareholders, the BRLMs, the Syndicate Members, Banker(s) to the Offer and the Registrar to the Offer.
4. Share Escrow Agreement dated November 17, 2021 entered into among the Selling Shareholders, our Company and the Share Escrow Agent.
5. Syndicate Agreement dated November 23, 2021 entered into among the members of the Syndicate Members, our Company, the Selling Shareholders and the Registrar to the Offer.
6. Underwriting Agreement dated [•] entered into among our Company, the Selling Shareholders and the Underwriters.

#### *Material Documents*

1. Certified copies of our Memorandum of Association and Articles of Association, as amended until date.
2. Certificate of incorporation dated May 15, 1976.
3. Fresh certificate of incorporation dated February 1, 2002 issued consequent to change in name of the Company from “Tega India Limited” to “Tega Industries Limited”.
4. Shareholders’ Agreement dated April 29, 2011 entered into by and among our Company, Wagner Limited and Madan Mohan Mohanka, Manish Mohanka, Mehul Mohanka, Madan Mohan Mohanka (HUF), Mehul Mohanka (HUF), NFSPL, Marudhar Food & Credit Limited read with the amendment agreements dated September 3, 2018, July 10, 2020 and August 2, 2021.
5. SHA Amendment Agreement dated August 7, 2021 entered into by and among our Company, Wagner Limited and our Promoters
6. Share Subscription and Purchase Agreement dated April 29, 2011 entered into by and among our Company, the Investor, and our Promoters read with the amendment agreements dated September 3, 2018, July 10, 2020 and August 2, 2021.
7. Joint Venture Agreement dated November 12, 1991 entered into between Hosch (G.B.) Limited, England and Madan Mohan Mohanka read with the Share purchase agreement dated May 29, 2010 between Madan Mohan Mohanka and Company.

8. ESOP 2011 and ESOP- 2021.
9. Resolution of the Board of Directors of our Company, dated April 30, 2021, approving the Offer and other related matters.
10. Resolution of the Board of Directors of our Company, dated August 16, 2021 and the IPO Committee of our Company dated August 17, 2021 approving the Draft Red Herring Prospectus for filing with SEBI and the Stock Exchanges.
11. Resolution of the Board of Directors of our Company, dated November 23, 2021 approving this Red Herring Prospectus for filing with RoC.
12. Consent letter dated August 16, 2021 and resolution of the board of directors of Wagner Limited, dated August 6, 2021 approving the participation of Wagner Limited in the Offer and other related matters.
13. Consent letters dated August 16, 2021 received from Madan Mohan Mohanka and Manish Mohanka consenting to their participation in the Offer and approving the inclusion of their names as the selling shareholders.
14. Copies of annual reports for the last three Financial Years, i.e., Financial Years 2021, 2020 and 2019.
15. Report titled “*Global Market Assessment – Select Mineral Processing Equipment*” dated October 12, 2021, issued by Frost & Sullivan and consent letter issued by Frost & Sullivan dated October 12, 2021, also available at the following weblink <https://www.tegaindustries.com/tega-investors/#indreport>
16. Statement of possible special tax benefits dated November 10, 2021 from the Independent Chartered Accountants included in this Red Herring Prospectus.
17. Consent of the Statutory Auditors dated November 23, 2021 to include their name as required under Section 26(5) of the Companies Act read with SEBI ICDR Regulations and referred to as an “expert” as defined under Section 2(38) of the Companies Act to the extent and in their capacity as the Statutory Auditor, and for inclusion of their examination report dated November 10, 2021 on our Restated Consolidated Financial Information in the form and context in which it appears in this Red Herring Prospectus. However, the term “expert” shall not be construed to mean an “expert” as defined under the U.S. Securities Act.
18. Consents of our Directors, Bankers to our Company, the BRLMs, Registrar to the Offer, Banker(s) to the Offer, Bankers to our Company, legal counsel, lenders to the Company, Directors of our Company, Chief Financial Officer and Company Secretary, and Compliance Officer, as referred to act, in their respective capacities.
19. In-principle listing approvals dated September 2, 2021 and September 8, 2021 from BSE and NSE, respectively.
20. Tripartite Agreement dated August 7, 2021 among our Company, NSDL and the Registrar to the Offer.
21. Tripartite Agreement dated August 4, 2021 among our Company, CDSL and the Registrar to the Offer.
22. Due diligence certificate addressed to SEBI from the BRLMs, dated August 17, 2021.
23. SEBI letter number SEBI/ERO/P/OW/2021/31046/1 dated October 29, 2021 granting exemption to the Company.
24. SEBI observation letter number SEBI/ERO/P/OW/2021/0000022981/1 dated September 7, 2021, email dated October 19, 2021 and final observation letter number SEBI/ERO/OW/2021/31045/1 dated October 29, 2021.

Any of the contracts or documents mentioned in this Red Herring Prospectus may be amended or modified at any time if so required in the interest of our Company or if required by the other parties, without reference to the shareholders, subject to compliance with the provisions contained in the Companies Act and other relevant statutes.

## DECLARATION

I hereby certify and declare that all relevant provisions of the Companies Act, 2013 and the rules, regulations and guidelines issued by the Government of India, or the rules, regulations of guidelines issued by the Securities and Exchange Board of India, established under Section 3 of the Securities and Exchange Board of India Act, 1992, as the case may be, have been complied with, and no statement made in this Red Herring Prospectus is contrary to the provisions of the Companies Act, 2013, the Securities Contracts (Regulation) Act, 1956, the Securities Contracts (Regulation) Rules, 1957, and the Securities Exchange Board of India Act, 1992, each as amended or the rules, regulations or guidelines issued thereunder, as the case maybe. I further certify that all the disclosures and statements made in this Red Herring Prospectus are true and correct.

SIGNED BY THE DIRECTOR OF OUR COMPANY



**Chairman and Executive Director**  
Madan Mohan Mohanka

Date: 23.11.2021  
Place: KOLKATA

## DECLARATION

I hereby certify and declare that all relevant provisions of the Companies Act, 2013 and the rules, regulations and guidelines issued by the Government of India, or the rules, regulations of guidelines issued by the Securities and Exchange Board of India, established under Section 3 of the Securities and Exchange Board of India Act, 1992, as the case may be, have been complied with, and no statement made in this Red Herring Prospectus is contrary to the provisions of the Companies Act, 2013, the Securities Contracts (Regulation) Act, 1956, the Securities Contracts (Regulation) Rules, 1957, and the Securities Exchange Board of India Act, 1992, each as amended or the rules, regulations or guidelines issued thereunder, as the case maybe. I further certify that all the disclosures and statements made in this Red Herring Prospectus are true and correct.

**SIGNED BY THE DIRECTOR OF OUR COMPANY**



**Managing Director**  
Mehul Mohanka

Date: 23.11.2021  
Place: KOLKATA

## DECLARATION

I hereby certify and declare that all relevant provisions of the Companies Act, 2013 and the rules, regulations and guidelines issued by the Government of India, or the rules, regulations of guidelines issued by the Securities and Exchange Board of India, established under Section 3 of the Securities and Exchange Board of India Act, 1992, as the case may be, have been complied with, and no statement made in this Red Herring Prospectus is contrary to the provisions of the Companies Act, 2013, the Securities Contracts (Regulation) Act, 1956, the Securities Contracts (Regulation) Rules, 1957, and the Securities Exchange Board of India Act, 1992, each as amended or the rules, regulations or guidelines issued thereunder, as the case maybe. I further certify that all the disclosures and statements made in this Red Herring Prospectus are true and correct.

**SIGNED BY THE DIRECTOR OF OUR COMPANY**



**Executive Director**  
Syed Yaver Imam

Date: 23.11.2021

Place: KOLKATA



## DECLARATION

I hereby certify and declare that all relevant provisions of the Companies Act, 2013 and the rules, regulations and guidelines issued by the Government of India, or the rules, regulations of guidelines issued by the Securities and Exchange Board of India, established under Section 3 of the Securities and Exchange Board of India Act, 1992, as the case may be, have been complied with, and no statement made in this Prospectus is contrary to the provisions of the Companies Act, 2013, the Securities Contracts (Regulation) Act, 1956, the Securities Contracts (Regulation) Rules, 1957, and the Securities Exchange Board of India Act, 1992, each as amended or the rules, regulations or guidelines issued thereunder, as the case maybe. I further certify that all the disclosures and statements made in this Prospectus are true and correct.

**SIGNED BY THE DIRECTOR OF OUR COMPANY**



**Independent Director**  
Jagdishwar Prasad Sinha

Date: 23.11.2021  
Place: Bangalore

## DECLARATION

I hereby certify and declare that all relevant provisions of the Companies Act, 2013 and the rules, regulations and guidelines issued by the Government of India, or the rules, regulations of guidelines issued by the Securities and Exchange Board of India, established under Section 3 of the Securities and Exchange Board of India Act, 1992, as the case may be, have been complied with, and no statement made in this Red Herring Prospectus is contrary to the provisions of the Companies Act, 2013, the Securities Contracts (Regulation) Act, 1956, the Securities Contracts (Regulation) Rules, 1957, and the Securities Exchange Board of India Act, 1992, each as amended or the rules, regulations or guidelines issued thereunder, as the case maybe. I further certify that all the disclosures and statements made in this Red Herring Prospectus are true and correct.

**SIGNED BY THE DIRECTOR OF OUR COMPANY**



---

**Independent Director**  
Hemant Nerurkar Madhusudan

Date: 23.11.2021  
Place: MUMBAI

## DECLARATION

I hereby certify and declare that all relevant provisions of the Companies Act, 2013 and the rules, regulations and guidelines issued by the Government of India, or the rules, regulations of guidelines issued by the Securities and Exchange Board of India, established under Section 3 of the Securities and Exchange Board of India Act, 1992, as the case may be, have been complied with, and no statement made in this Red Herring Prospectus is contrary to the provisions of the Companies Act, 2013, the Securities Contracts (Regulation) Act, 1956, the Securities Contracts (Regulation) Rules, 1957, and the Securities Exchange Board of India Act, 1992, each as amended or the rules, regulations or guidelines issued thereunder, as the case maybe. I further certify that all the disclosures and statements made in this Red Herring Prospectus are true and correct.

**SIGNED BY THE DIRECTOR OF OUR COMPANY**



**Independent Director**  
Rudolph Michael Edge

Date: 23.11.2021

Place: MELBOURNE

## DECLARATION

I hereby certify and declare that all relevant provisions of the Companies Act, 2013 and the rules, regulations and guidelines issued by the Government of India, or the rules, regulations of guidelines issued by the Securities and Exchange Board of India, established under Section 3 of the Securities and Exchange Board of India Act, 1992, as the case may be, have been complied with, and no statement made in this Red Herring Prospectus is contrary to the provisions of the Companies Act, 2013, the Securities Contracts (Regulation) Act, 1956, the Securities Contracts (Regulation) Rules, 1957, and the Securities Exchange Board of India Act, 1992, each as amended or the rules, regulations or guidelines issued thereunder, as the case maybe. I further certify that all the disclosures and statements made in this Red Herring Prospectus are true and correct.

### SIGNED BY THE DIRECTOR OF OUR COMPANY

A handwritten signature in blue ink, appearing to read 'M. Dubhashi', is written over a horizontal line.

**Independent Director**  
Madhu Dubhashi

Date: 23.11.2021

Place: PUNE

## DECLARATION

I hereby certify and declare that all relevant provisions of the Companies Act, 2013 and the rules, regulations and guidelines issued by the Government of India, or the rules, regulations of guidelines issued by the Securities and Exchange Board of India, established under Section 3 of the Securities and Exchange Board of India Act, 1992, as the case may be, have been complied with, and no statement made in this Red Herring Prospectus is contrary to the provisions of the Companies Act, 2013, the Securities Contracts (Regulation) Act, 1956, the Securities Contracts (Regulation) Rules, 1957, and the Securities Exchange Board of India Act, 1992, each as amended or the rules, regulations or guidelines issued thereunder, as the case maybe. I further certify that all the disclosures and statements made in this Red Herring Prospectus are true and correct.

**SIGNED BY CHIEF FINANCIAL OFFICER OF OUR COMPANY**



**Chief Financial Officer**  
Manoj Kumar Agarwal

Date: 23-11-2021  
Place: KOLKATA

**DECLARATION BY MADAN MOHAN MOHANKA, AS A PROMOTER SELLING SHAREHOLDER**

I, Madan Mohan Mohanka, hereby confirm that all statements and undertakings specifically made or confirmed by me in this Red Herring Prospectus in relation to myself, as a Promoter Selling Shareholder and my respective portion of the Offered Shares, are true and correct. I assume no responsibility for any other statements including statements made by or relating to the Company or any other person(s) in this Red Herring Prospectus.



---

**Name:** Madan Mohan Mohanka

**Date:** 23-11-2021

**Place:** KOLKATA

**DECLARATION BY MANISH MOHANKA, AS A PROMOTER SELLING SHAREHOLDER**

I, Manish Mohanka, hereby confirm that all statements and undertakings specifically made or confirmed by me in this Red Herring Prospectus in relation to myself, as a Promoter Selling Shareholder and my respective portion of the Offered Shares, are true and correct. I assume no responsibility for any other statements including statements made by or relating to the Company or any other person(s) in this Red Herring Prospectus.

Manish Mohanka

**Name:** Manish Mohanka

**Date:** 23.11.2021

**Place:** KOLKATA

**DECLARATION BY WAGNER LIMITED, AS AN INVESTOR SELLING SHAREHOLDER**

We, Wagner Limited, hereby confirm that all statements and undertakings specifically made or confirmed by us in this Red Herring Prospectus in relation to ourself, as an Investor Selling Shareholder and my respective portion of the Offered Shares, are true and correct. Wagner Limited assumes no responsibility for any other statements including statements made by or relating to the Company or any other person(s) in this Red Herring Prospectus.



Name: Resmah Mandary  
Designation: Director

Date: 23.11.2021

